

■ Features

- 85~264Vac input with PFC
- Global certificates in multi-fields (ITE 62368-1, Industrial 61558-1/-2-16, 61010)
- 48mm slim width
- High efficiency up to 96% and no load power dissipation < 1.2W
- Built-in constant current limiting circuit
- Current sharing up to 1920W (3+1) for parallel use
- Protections: Short circuit / Overload / Over voltage / Over temperature
- Fanless design, cooling by free air convection
- Over voltage category III (OVC III)
- -40~+70°C wide range operation temperature (>+50°C derating)
- Operating altitude up to 5000 meters
- Built-in DC OK relay contact
- Can be installed on DIN rail TS-35/7.5 or 15
- 3 years warranty

■ Description

The XDR-480E series is a 480W AC/DC economical ultra slim industrial DIN rail power. Key features of this series include a narrow 48mm casing, optimizing system installation space, and an ultra-wide input range of 85~264Vac suitable for global use. It boasts a maximum efficiency of 96% and a low standby power consumption < 1.2W for energy savings and carbon reduction. It has built-in constant current, fanless design, a wide operating temperature range of -40 to +70°C (up to +50°C at full load); OVCIII compliance; parallel function capability up to 1920W; built-in DC OK signal. With comprehensive protection functions, complete safety certifications, and a 3-years warranty, the XDR-480E series is a compact, high-performance, and highly reliable DIN rail power supply.

■ Model Encoding

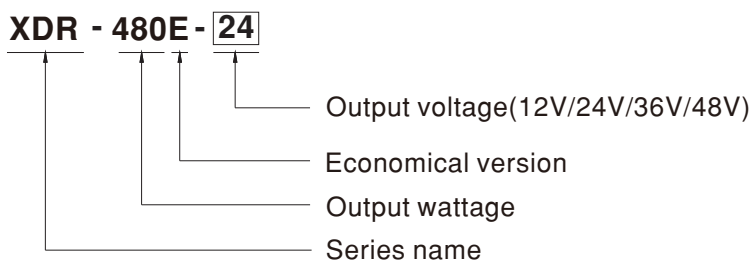

■ Applications

- Industrial control system
- Semiconductor fabrication equipment
- Factory automation
- Electro-mechanical apparatus
- Battery charger

■ GTIN CODE

MW Search: <https://www.meanwell.com/serviceGTIN.aspx>



480W AC/DC Economical Ultra Slim Industrial DIN Rail Power **XDR-480E** series

SPECIFICATION	XDR-480E-12	XDR-480E-24	XDR-480E-36	XDR-480E-48
OUTPUT				
DC VOLTAGE	12V	24V	36V	48V
RATED CURRENT	30A	20A	13.3A	10A
CURRENT RANGE	0 ~ 30A	0 ~ 20A	0 ~ 13.3A	0 ~ 10A
RATED POWER	360W	480W	478.8W	480W
RIPPLE & NOISE (max.) Note.2	100mVp-p	120mVp-p	150mVp-p	150mVp-p
VOLTAGE ADJ. RANGE	12 ~ 15V	24 ~ 29V	36 ~ 42V	48 ~ 55V
VOLTAGE TOLERANCE Note.3	±2.0%	±1.0%	±1.0%	±1.0%
LINE REGULATION	±0.5%	±0.5%	±0.5%	±0.5%
LOAD REGULATION	±1.0%	±1.0%	±1.0%	±1.0%
SETUP, RISE TIME	1500ms, 150ms/230Vac 3000ms, 150ms/115Vac at full load			
HOLD UP TIME (Typ.)	15ms/230Vac 15ms/115Vac at full load			
INPUT				
AC VOLTAGE RANGE	85 ~ 264Vac			
DC VOLTAGE RANGE	120 ~ 370Vdc			
NO LOAD POWER CONSUMPTION (Typ.)	1W @115Vac & 230Vac		1.2W @115Vac & 230Vac	
FREQUENCY RANGE	47 ~ 63Hz			
POWDR FACTOR (Typ.)	PF>0.95/230Vac PF>0.98/115Vac at full load			
EFFICIENCY (Typ.)	94%	95.5%	95.5%	96%
AC CURRENT (Typ.)	6A/115Vac 3A/230Vac			
INRUSH CURRENT (Typ.)	COLD START 15A/115Vac 30A/230Vac			
LEAKAGE CURRENT	<1mA / 240Vac			
PROTECTION				
OVERLOAD	105~130% rated output power			
	Hiccup mode when output voltage <30%, recovers automatically after fault condition is removed			
	Constant current limiting without shutdown within 30%~100% rated output voltage, recovers automatically after fault condition is removed			
OVER VOLTAGE	Max. 18V	Max. 35V	Max. 50V	Max. 63V
	Protection type : Hiccup mode, recovers automatically after fault condition is removed.			
OVER TEMPERATURE	Protection type : Shut down o/p voltage, recovers automatically after temperature goes down			
FUNCTION				
PARALLEL (Droop Mode)	Up to 1920W Max (3+1) units; Please refer to Function Manual for more details			
DC OK RELAY CONTACT	Relay Contact Ratings (max.): 30Vdc/1A, 30Vac/0.5A resistive load			
ENVIRONMENT				
WORKING TEMP.	-40 ~ +70°C (Refer to "Derating Curve")			
WORKING HUMIDITY	20 ~ 95% RH non-condensing			
STORAGE TEMP., HUMIDITY	-40 ~ +85°C, 10 ~ 95% RH non-condensing			
TEMP. COEFFICIENT	±0.03% /°C (0 ~ 50°C)			
VIBRATION	Component: 10 ~ 500Hz, 2G 10min./1cycle, 60min. each along X, Y, Z axes; Mounting: Compliance to IEC60068-2-6			



480W AC/DC Economical Ultra Slim Industrial DIN Rail Power **XDR-480E** series

SPECIFICATION	XDR-480E-12	XDR-480E-24	XDR-480E-36	XDR-480E-48
SAFETY & EMC Note.6&7&8				
SAFETY STANDARDS	CB IEC 62368-1, IEC 61558-1/2-16, IEC 61010-1/2-201 TUV BS EN/EN 62368-1, BS EN /EN 61558-1/2-16, BS EN/EN 61010-1/2-201 UL UL/CUL 61010-1/2-201 CCC GB4943.1 BSMI CNS15598-1 EAC TPTC004 approved KC/BIS KC 62368-1 and BIS IS 13252 (Part 1) certified, no stock by request ,contact sales for inquires			
OVER VOLTAGE CATEGORY Note.4	IEC/EN 61558-1/2-16 (OVC III, altitude up to 2000m) IEC/EN/UL 61010-1/2-201 (OVC II, altitude up to 5000m) IEC/EN 62368-1 (OVC II, altitude up to 5000m)			
SAFETY EXTRA-LOW VOLTAGE(SELV)	IEC/EN 61558-2-16 (SELV) IEC/EN 62368-1 (SELV / ES1)			
WITHSTAND VOLTAGE	I/P-O/P: 4KVac I/P-FG: 2KVac O/P-FG: 1.5KVac O/P-DC OK: 0.5KVac			
ISOLATION RESISTANCE	I/P-O/P, I/P-FG, O/P-FG: 100M Ohms/500Vdc/25°C / 70%RH			
EMC EMISSION	Parameter	Standard		Test Level / Note
	Conducted	BS EN/EN55032 (CISPR32) / BS EN/EN61204-3 / CNS15936 / KS C 9832		Class B
	Radiated	BS EN/EN55032 (CISPR32) / BS EN/EN61204-3 / CNS15936 / KS C 9832		Class B
	Harmonic Current	BS EN/EN61000-3-2		Class A
	Voltage Flicker	BS EN/EN61000-3-3		-----
EMC IMMUNITY	BS EN/EN55035 , BS EN/EN61204-3, BS EN/EN61000-6-2(BS EN/EN50082-2), KS C 9835			
	Parameter	Standard		Test Level / Note
	ESD	BS EN/EN61000-4-2		Level 3, 8KV air ; Level 2, 4KV contact; criteria A
	Radiated	BS EN/EN61000-4-3		Level 3, 10V/m ; criteria A
	EFT / Burst	BS EN/EN61000-4-4		Level 3, 2KV ; criteria A
	Surge	BS EN/EN61000-4-5		Level 4, 2KV/Line-Line ;Level 4, 4KV/Line-Line-Chassis ;criteria A
	Conducted	BS EN/EN61000-4-6		Level 3, 10V ; criteria A
	Magnetic Field	BS EN/EN61000-4-8		Level 4, 30A/m ; criteria A
OTHERS				
MTBF	1482.0K hrs min. Telcordia SR-332 (Bellcore) ; 258.3K hrs min. MIL-HDBK-217F (25°C)			
DIMENSION	48*125.2*125mm (W*H*D)			
PACKING	890g; 12pcs/13Kg/1.16CUFT			
NOTE				
1. All parameters NOT specially mentioned are measured at 230Vac input, rated load and 25°C of ambient temperature. 2. Ripple & noise are measured at 20MHz of bandwidth by using a 12" twisted pair-wire terminated with a 0.1 μF & 47 μF parallel capacitor. 3. Tolerance : includes set up tolerance, line regulation and load regulation. 4. The ambient temperature derating of 3.5°C/1000m with fanless models and of 5°C/1000m with fan models for operating altitude higher than 2000m(6500ft). 5. Installation clearances : 40mm on top, 20mm on the bottom, 5mm on the left and right side are recommended when loaded permanently with full power. In case the adjacent device is a heat source, 15mm clearance is recommended. 6. The power supply is considered a component which will be installed into a final equipment. The final equipment must be re-confirmed that it still meets EMC directives. (as available on https://www.meanwell.com/Upload/PDF/EMI_statement_en.pdf) 7. The Regulatory Compliance Mark (RCM) is applied on a voluntary basis. The equipment meets the relevant IEC or AS/NZS standards, or AS/NZS 3820 where applicable. The use of the RCM mark complies with AS/NZS 4417.1. 8. Some factory or model may not have the BIS logo, please contact your MEAN WELL sales for more information. ※ Product Liability Disclaimer : For detailed information, please refer to https://www.meanwell.com/serviceDisclaimer.aspx				

■ Block Diagram

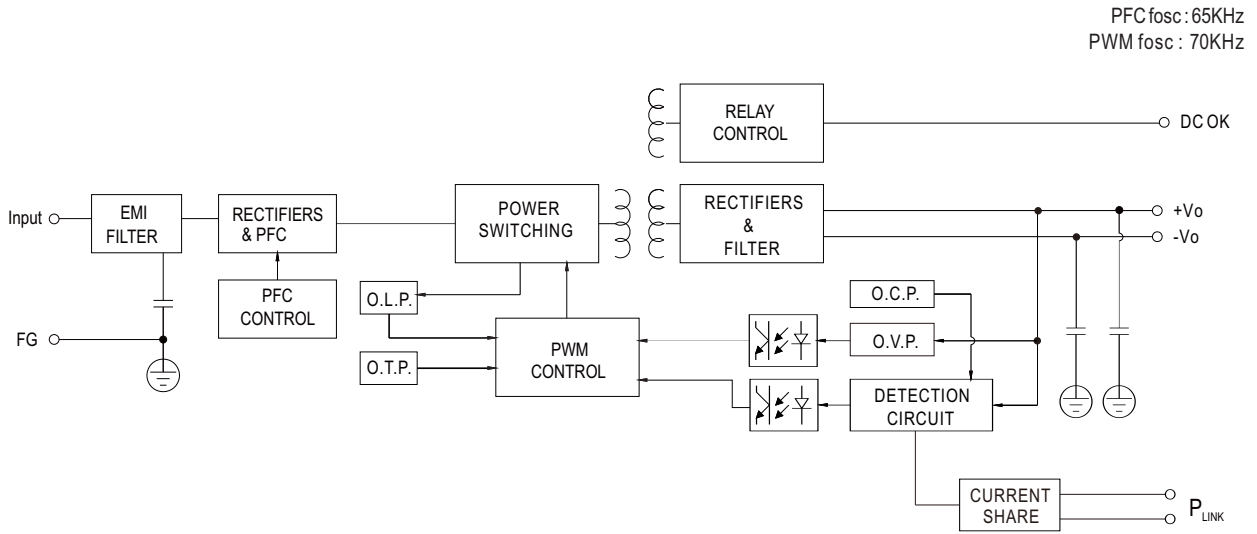

■ Derating Curve

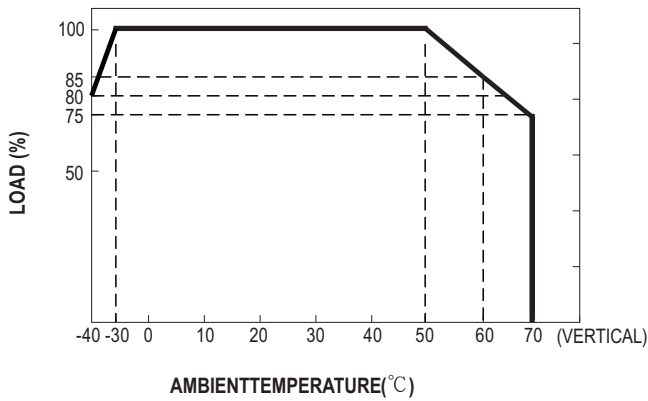

■ Static Characteristics

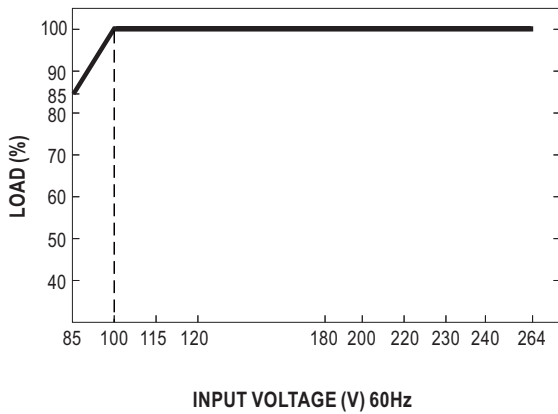

Function Manual

Pin No.	Function	Description
1,2	DC OK Relay Contact	Contact Close: PSU turns ON/DC_OK Contact Open: PSU turns OFF/DC_fail
3,4	Paraller Use Link(P _{LINK})	P _{LINK} should be short to enable droop parallel use.(Default disable)

1.DC OK Relay Contact

Contact Close	PSU turns ON/DC OK.
Contact Open	PSU turns OFF/DC Fail.
Contact Ratings (max.)	30Vdc/1A, 30Vac/0.5A resistive load.

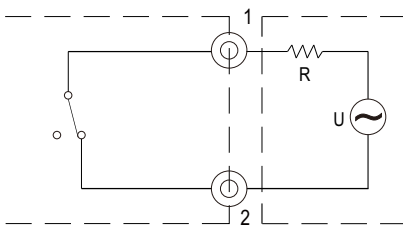

External voltage source (U) and resistor (R)
(The max. Sink is 30Vdc/1A ,30Vac/0.5A)

Internal circuit of DC_OK, via relay contact

2.Parallel Use

XDR-480E has the built-in **droop mode current sharing** function and can be connected in parallel, up to 4 units, to provide higher output power as exhibited below :

- (1) Difference of output voltages among parallel units should be less than **0.1V**.
- (2) The total output current must not exceed the value determined by the following equation (Output current at parallel operation)=(The rated current per unit) x (Number of unit) x 0.9.
- (3) In parallel operation 4 units is the maximum, please consult the manufacture for other applications.
- (4) The power supplies should be paralleled using short and large diameter wiring and then connected to the load.
- (5) When in parallel operation, the minimum output load should be greater than 7% of total output load. (Min. load >7% rated current per unit x number of unit)
- (6) In parallel connection, maybe only one unit (master) operate if the total output load is less than 7% of rated load condition.
The other PSUs (slaves) may go into standby mode and their output LEDs & relays will not turn on.
- (7) **P_{LINK} lines should be shorted locally.**
- (8) In parallel operation,after overload or short circuit fault occurs, re-power on to recover.
- (9) The "Parallel Use" mode regulates the output voltage in such a manner that the rated load is approx. 4% lower than the no-load voltage (12V:approx.8%).

For example XDR-480E-24:

No load output voltage=24V

Normal load output current=20A

0~100% load output voltage=24V~23V

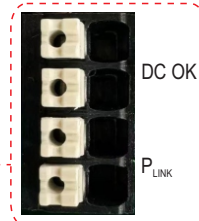
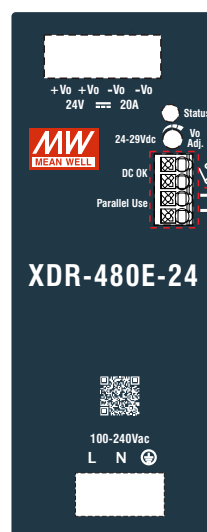
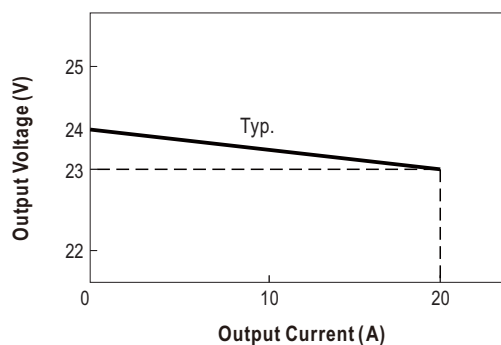

Enable : P_{LINK} should be short

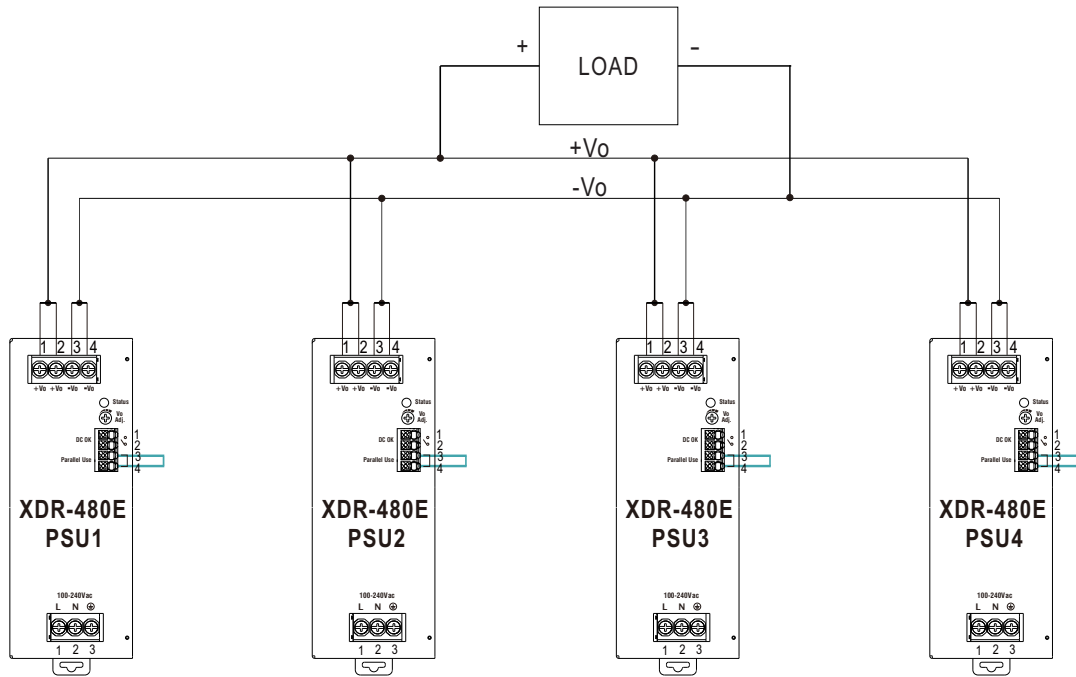

※ Please contact MEAN WELL for more details.

■ Mechanical Specification

(Unit:mm , Tolerance ± 1 mm)

Case No.303

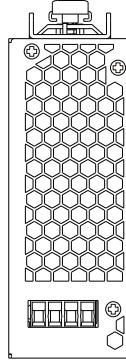

Ⓐ : Terminal Pin No.Assignment

Pin No.	Assignment
1,2	DC Output +Vo
3,4	DC Output -Vo

Ⓑ : Control Pin No.Assignment

Pin No.	Assignment
1,2	DC OK Relay Contact
3,4	Parallel Use Link(Current Sharing)

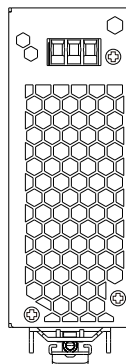
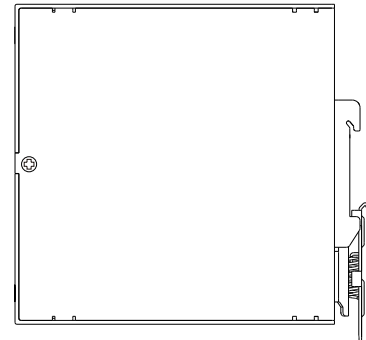
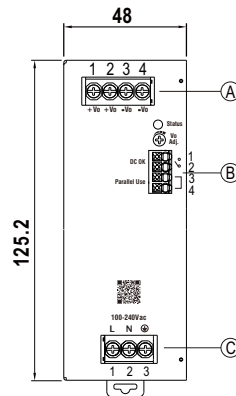
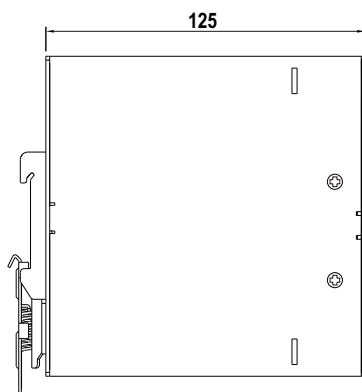

Ⓒ : Terminal Pin No.Assignment

Pin No.	Assignment
1	AC/L or DC Input +Vin
2	AC/N or DC Input -Vin
3	FG Ⓧ

■ Recommend Wiring

		AC Input T.B	DC Output T.B	Signal connector
Solid Wire		6mm ² max.	6mm ² max.	1.5mm ² max.
A.W.G	XDR-480E-12	18~10 AWG	12~10 AWG	24~16 AWG
	XDR-480E-24/36/48		16~10 AWG	
Wire Stripping Length		10~11mm	10~11mm	8~9mm
Screw Terminal Torque		5 Lb-In	5 Lb-In	/



■ Installation Instruction

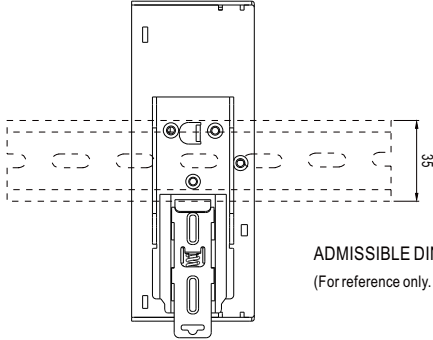

ADMISSIBLE DIN-RAIL: TS35/7.5 OR TS35/15
(For reference only. Not included with unit.)

This series fits DIN rail TS35/7.5 or TS35/15.
For installation details, please refer to the Instruction manual.

■ Installation Manual

Please refer to : <http://www.meanwell.com/manual.html>