



SPWM-75/150/240series

User Manual



Constant Voltage PWM style Output LED Driver



The SPWM series is the latest AC to DC constant voltage PWM style output LED driver launched by MEAN WELL. The output power includes 75W/150W/240W, covering 12V/24V/48V output voltage. It is suitable for directly driving various LED strips, which can maintain colour temperature stability and ensure brightness uniformity. The entire series adopts a fanless design, which can operate in an ambient temperature range of -20 °C~+50 °C under free air convection. The entire series has multiple dimming functions (3 in 1 dimming/DALI-2 + push dimming, etc.), supporting DALI-2 DT6 and DT8 device types, providing the best design flexibility for lighting systems.

Contents

1. Safety Guidelines	1
2. Introduction	1
2.1 Model Encoding	1
2.2 Features	1
2.3 Specification	2
2.4 Mechanical Specification	5
2.4.1 SPWM-75 series	5
2.4.2 SPWM-150 series	6
2.4.3 SPWM-240 series	7
2.5 Connecting Terminal	8
2.5.1 Terminal definition	8
2.5.2 Wiring requirements	8
2.6 Installation	9
2.6.1 Installation method	9
2.6.2 Installation precautions	10
3. DA2Q Type Application Settings	11
4. Dimming Operation	12
4.1 Dimming principle	12
4.2 Three in one dimming function	15
4.3 Push dimming	16
4.3.1 DA2 type push dimming instructions	16
4.3.2 DA2Q type push dimming instructions	16
5. DALI-2 System Application	18
6. Application Examples	19
6.1 SPWM-DA2Q and touch panel example	19
6.2 SPWM-DA2Q and PIR motion sensor example	28
7. Protection Function	37
8. Warranty	38
9. Environmental Declaration Information	38

1.Safety Guidelines

- Risk of electrical shock and energy hazard, all failure should be examined by a qualified technician. Please do not remove the case from the power supply by yourself.
- Do not install this product in damp, high temperature, direct sunlight, or near fire sources.
- Do not install or wire the product while it is powered on.
- Please follow the specifications for input voltage and do not exceed the rated usage.
- Before power on debugging, please ensure that all wiring is correct and secure to avoid short circuits that may damage components and cause accidents.

2.Introduction

2.1 Model Encoding

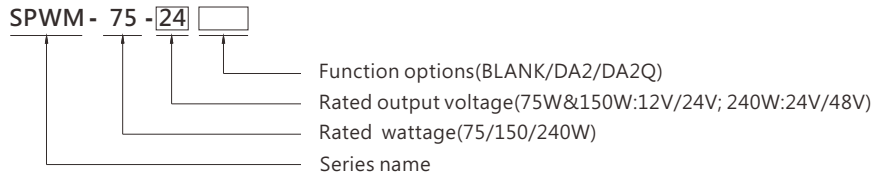

Type	Function	Note
BLANK	3 in 1 dimming function (0~10Vdc,10V PWM signal and resistance)	In stock
DA2	DALI-2 with DT6 control(1 channel output)	In stock
DA2Q	DALI-2 with DT8 control(4 channels output)	In stock

2.2 Features

- DALI-2 DT6(Dimming) or DT8 (Tunable white/RGBW) control available
- Constant voltage PWM style output with 1 to 4 channels
- Standby power consumption <0.5W
- Flicker free, complying with CE ErP directive
- Plastic housing with class II and PFC design
- Function options: 3 in 1dimming/DALI-2+PUSH Dimming
- Minimum dimming level 0.1%(DALI-2)
- Cooled by free air convection
- 5 years warranty.

2.3 Specification

※ SPWM-75 series

SPECIFICATION	SPWM-75-12□	SPWM-75-24□	
OUTPUT			
DC VOLTAGE	12V	24V	
RATED CURRENT(Max.)	6.3A	3.2A	
RATED POWER(Max.)	75.6W	76.8W	
VOLTAGE ADJ. RANGE	11~14V	23~26V	
PWM FREQUENCY (Typ.)	3.2kHz		
SETUP, RISE TIME Note.3	500ms,80ms/ 230VAC ,1200ms,80ms/115VAC		
HOLD UP TIME (Typ.)	10ms/230VAC or 115VAC		
INPUT			
VOLTAGE RANGE Note.2	100 ~ 305VAC 156 ~ 410VDC (Please refer to "STATIC CHARACTERISTIC" section)		
FREQUENCY RANGE	47 ~ 63Hz		
POWER FACTOR (Typ.)	PF> 0.97/115VAC, PF>0.95/230VAC, PF>0.92/277VAC @ full load (Please refer to "POWER FACTOR (PF) CHARACTERISTIC" section)		
TOTAL HARMONIC DISTORTION	THD<10%@load≥50%/115VAC, 230VAC; @load≥75%/277VAC (Please refer to "TOTAL HARMONIC DISTORTION" section)		
EFFICIENCY (Typ.)	89%	90%	
AC CURRENT (Typ.)	0.9A / 115VAC	0.45A / 230VAC 0.38A / 277VAC	
INRUSH CURRENT (Typ.)	COLD START 50A(twidth=500μs measured at 50% Ipeak) at 230VAC; Per NEMA 410		
MAX. NO. of PSUs on 16A CIRCUIT BREAKER	5 units (circuit breaker of type B) / 8 units (circuit breaker of type C) at 230VAC		
LEAKAGE CURRENT	<0.25mA / 277VAC		
STANDBY POWER CONSUMPTION	standby power consumption<0.5W (Dimming off)		
PROTECTION			
OVERLOAD	105~135%, hiccup mode, recovers automatically after fault condition is removed		
SHORT CIRCUIT	Blank type: Shut down O/P voltage, re-power on to recover after fault condition is removed DA2/DA2Q type:Hiccup mode, recovers automatically after fault condition is removed		
OVER VOLTAGE	15 ~ 20V	27 ~ 36V	
OVER TEMPERATURE	Shut down O/P voltage, re-power on to recover after fault condition is removed		
ENVIRONMENT			
WORKING TEMP.	Tcase=-20~ +90°C (Please refer to " OUTPUT LOAD vs TEMPERATURE" section)		
MAX. CASE TEMP.	Tcase=90°C		
WORKING HUMIDITY	20 ~ 95% RH non-condensing		
STORAGE TEMP, HUMIDITY	-40 ~ +80°C, 10 ~ 95% RH		
TEMP. COEFFICIENT	±0.03%/°C (0 ~ 50°C)		
VIBRATION	5 ~ 100Hz, 2G 12min./1cycle, each along X,Y,Z axes according to EN50090-2-2		
SAFETY & EMC			
SAFETY STANDARDS	UL8750(Class P),CSA C22.2 No.250.13-12; ENEC BS EN/EN61347-1, BS EN/EN61347-2-13(EL) appendix J suitable for emergency installations(DC input 176-280VDC), BS EN/EN62384; GB/T19510.1,GB/T19510.213; EAC TP TC 004; Design refer to AS/NZS 61347-1, AS/NZS 61347-2-13		
DALI STANDARDS	Comply with IEC62386-101, 102, 207(DT6),209(DT8),DALI Part 251		
WITHSTAND VOLTAGE	I/P-O/P:3.75KVAC		
ISOLATION RESISTANCE	I/P-O/P:100M Ohms / 500VDC / 25°C / 70% RH		
EMC EMISSION Note.4	Parameter	Standard	Test Level/Note
	Conducted	BS EN/EN55015(CISPR15) ,GB/T17743	-----
	Radiated	BS EN/EN55015(CISPR15) ,GB/T17743	-----
	Harmonic Current	BS EN/EN61000-3-2 ,GB 17625.1	Class C @load≥50%
	Voltage Flicker	BS EN/EN61000-3-3	-----
EMC IMMUNITY	BS EN/EN61547		
	Parameter	Standard	Test Level/Note
	ESD	BS EN/EN61000-4-2	Level 3, 8KV air; Level 2, 4KV contact
	Radiated	BS EN/EN61000-4-3	Level 2
	EFT/Burst	BS EN/EN61000-4-4	Level 2
	Surge	BS EN/EN61000-4-5	Level 4, 2KV/Line-Line
	Conducted	BS EN/EN61000-4-6	Level 2
Magnetic Field	BS EN/EN61000-4-8	Level 2	
	Voltage Dips and Interruptions	BS EN/EN61000-4-11:2020	30% dip 10 periods 100% interruption 0.5 periods
OTHERS			
FLICKER Note.9	PstLM ≤ 1, SVM ≤ 0.4		
MTBF	2396.9 K hrs min. Telcordia SR-332 (Bellcore);	205.7 K hrs min. MIL-HDBK-217F (25°C)	
DIMENSION	290*38*28.5mm (L*W*H)		
PACKING	0.28Kg; 42 pcs/ 13.5 Kg/ 0.67 CUFT		
NOTE			
1. All parameters NOT specially mentioned are measured at 230VAC input, rated current and 25°C of ambient temperature.			
2. De-rating may be needed under low input voltages. Please refer to "STATIC CHARACTERISTIC" sections for details.			
3. Length of set up time is measured at first cold start. Turning ON/OFF the driver may lead to increase of the set up time.			
4. The driver is considered as a component that will be operated in combination with final equipment. Since EMC performance will be affected by the complete installation, the final equipment manufacturers must re-qualify EMC Directive on the complete installation again.			
5. This series meets the typical life expectancy of >50,000 hours of operation when Tcase, particularly @ point (or TMP, per DLC), is about 75°C or less.			
6. Please refer to the warranty statement on MEAN WELL's website at http://www.meanwell.com			
7. The ambient temperature derating of 3.5°C/1000m with fanless models and of 5°C/1000m with fan models for operating altitude higher than 2000m(6500ft).			
8. It is not recommended to connect to capacitive loads.			
9. Flicker is measured at full load with the light source provided by MEAN WELL.			
10. RCM is on a voluntary basis. Non-IC classification Independent LED control gear is not suitable for residential installations.			
11. Based on IEC 62386-101/102 DALI power on timing and interruption regulations, the set up time needs to test with a DALI controller which can support for DALI power on function, otherwise the set up time will be higher than 0.5 second for DA2 type			
※ Product Liability Disclaimer : For detailed information, please refer to https://www.meanwell.com/serviceDisclaimer.aspx			

※ SPWM-150 series

SPECIFICATION	SPWM-150-12□	SPWM-150-24□	
OUTPUT			
DC VOLTAGE	12V	24V	
RATED CURRENT(Max.)	12.5A	6.3A	
RATED POWER(Max.)	150W	151.2W	
VOLTAGE ADJ. RANGE	11~14V	23~26V	
PWM FREQUENCY (Typ.)	3.2kHz		
SETUP RISE TIME Note.3	500ms,80ms/230VAC ,1200ms,80ms/115VAC		
HOLD UP TIME (Typ.)	10ms/230VAC or 115VAC		
INPUT			
VOLTAGE RANGE Note.2	100 ~ 305VAC	156 ~ 410VDC (Please refer to "STATIC CHARACTERISTIC" section)	
FREQUENCY RANGE	47 ~ 63Hz		
POWER FACTOR (Typ.)	PF>0.97/115VAC, PF>0.95/230VAC, PF>0.92/277VAC @ full load (Please refer to "POWER FACTOR (PF) CHARACTERISTIC" section)		
TOTAL HARMONIC DISTORTION	THD <10% @load≥50%/115VAC, 230VAC; @load≥75%/277VAC (Please refer to "TOTAL HARMONIC DISTORTION" section)		
EFFICIENCY (Typ.)	92%	93%	
AC CURRENT (Typ.)	1.5A / 115VAC	1A / 230VAC 0.8A / 277VAC	
INRUSH CURRENT (Typ.)	COLD START 55A(twidth=500μs measured at 50% Ipeak) at 230VAC; Per NEMA 410		
MAX. NO. of PSUs on 16A CIRCUIT BREAKER	5 units (circuit breaker of type B) / 8 units (circuit breaker of type C) at 230VAC		
LEAKAGE CURRENT	<0.25mA / 277VAC		
STANDBY POWER CONSUMPTION	Standby power consumption<0.5W (Dimming off)		
PROTECTION			
OVERLOAD	105~150%, hiccup mode, recovers automatically after fault condition is removed		
SHORT CIRCUIT	Blank type: Shut down O/P voltage, re-power on to recover after fault condition is removed DA2/DA2Q type:Hiccup mode, recovers automatically after fault condition is removed		
OVER VOLTAGE	15 ~ 20V	27 ~ 36V	
OVER TEMPERATURE	Shut down O/P voltage, re-power on to recover after fault condition is removed		
ENVIRONMENT			
WORKING TEMP.	Tcase=-20~+80°C (Please refer to " OUTPUT LOAD vs TEMPERATURE" section)		
MAX. CASE TEMP.	Tcase=80°C		
WORKING HUMIDITY	20 ~ 95% RH non-condensing		
STORAGE TEMP., HUMIDITY	-40 ~ +80°C, 10 ~ 95% RH		
TEMP. COEFFICIENT	±0.03%/°C (0 ~ 50°C)		
VIBRATION	5 ~ 100Hz, 2G 12min./1cycle, each along X,Y,Z axes according to EN50090-2-2		
SAFETY & EMC			
SAFETY STANDARDS	UL8750(Class P),CSA C22.2 No.250.13-12; ENEC BS EN/EN61347-1, BS EN/EN61347-2-13(EL) appendix J suitable for emergency installations(DC input 176-280VDC), BS EN/EN62384; GB/T19510.1,GB/T19510.2,13; EAC TP TC 004; Design refer to AS/NZS 61347-1, AS/NZS 61347-2-13		
DALI STANDARDS	Comply with IEC62386-101, 102, 207(DT6),209(DT8),DALI Part 251		
WITHSTAND VOLTAGE	I/P-O/P: 3.75KVAC		
ISOLATION RESISTANCE	I/P-O/P:100M Ohms / 500VDC / 25°C/ 70% RH		
EMC EMISSION Note.4	Parameter	Standard	Test Level/Note
	Conducted	BS EN/EN55015(CISPR15), GB/T17743	-----
	Radiated	BS EN/EN55015(CISPR15), GB/T17743	-----
	Harmonic Current	BS EN/EN61000-3-2, GB 17625.1	Class C @load ≥ 50%
	Voltage Flicker	BS EN/EN61000-3-3	-----
EMC IMMUNITY	BS EN/EN61547		
	Parameter	Standard	Test Level/Note
	ESD	BS EN/EN61000-4-2	Level 3, 8KV air ; Level 2, 4KV contact
	Radiated	BS EN/EN61000-4-3	Level 2
	EFT/Burst	BS EN/EN61000-4-4	Level 2
	Surge	BS EN/EN61000-4-5	Level 4, 2KV/Line-Line
	Conducted	BS EN/EN61000-4-6	Level 2
	Magnetic Field	BS EN/EN61000-4-8	Level 2
	Voltage Dips and Interruptions	BS EN/EN61000-4-11:2020	30% dip 10 periods 100% interruption 0.5 periods
	OTHERS		
FLICKER Note.9	PstLM < 1, SVM < 0.4		
MTBF	1926.4K hrs min. Telcordia SR-332 (Bellcore); 158.1K hrs min. MIL-HDBK-217F (25°C)		
DIMENSION	340*38*28.5mm (L*W*H)		
PACKING	0.40Kg; 30 pcs/ 12.5 Kg/ 0.66 CUFT		
NOTE			
1. All parameters NOT specially mentioned are measured at 230VAC input, rated current and 25°C of ambient temperature.			
2. De-rating may be needed under low input voltages. Please refer to "STATIC CHARACTERISTIC" sections for details.			
3. Length of set up time is measured at first cold start. Turning ON/OFF the driver may lead to increase of the set up time.			
4. The driver is considered as a component that will be operated in combination with final equipment. Since EMC performance will be affected by the complete installation, the final equipment manufacturers must re-qualify EMC Directive on the complete installation again.			
5. This series meets the typical life expectancy of >50,000 hours of operation when Tcase, particularly Ⓞpoint (or TMP, per DLC), is about 75°C or less.			
6. Please refer to the warranty statement on MEAN WELL's website at http://www.meanwell.com			
7. The ambient temperature derating of 3.5°C/1000m with fanless models and of 5°C/1000m with fan models for operating altitude higher than 2000m(6500ft).			
8. It is not recommended to connect to capacitive loads.			
9. Flicker is measured at full load with the light source provided by MEAN WELL.			
10. RCM is on a voluntary basis. Non-IC classification independent LED control gear is not suitable for residential installations.			
11. Based on IEC 62386-101/102 DALI power on timing and interruption regulations, the set up time needs to test with a DALI controller which can support for DALI power on function, otherwise the set up time will be higher than 0.5 second for DA2 type.			
※ Product Liability Disclaimer : For detailed information, please refer to https://www.meanwell.com/serviceDisclaimer.aspx			

※ SPWM-240 series

SPECIFICATION	SPWM-240-24□	SPWM-240-48□	
OUTPUT			
DC VOLTAGE	24V	48V	
RATED CURRENT(Max.)	10A	5A	
RATED POWER(Max.)	240W	240W	
VOLTAGE ADJ. RANGE	23~26V	47~50V	
PWM FREQUENCY (Typ.)	3.2kHz		
SETUP RISE TIME Note.3	500ms, 80ms/230VAC		
HOLD UP TIME (Typ.)	10ms/230VAC		
INPUT			
VOLTAGE RANGE Note.2	180 ~ 305VAC	255 ~ 410VDC (Please refer to "STATIC CHARACTERISTIC" section)	
FREQUENCY RANGE	47 ~ 63Hz		
POWER FACTOR (Typ.)	PF>0.95/230VAC, PF>0.92/277VAC @ full load (Please refer to "POWER FACTOR (PF) CHARACTERISTIC" section)		
TOTAL HARMONIC DISTORTION	THD <10% @load≥50%, 230VAC; @load≥75%/277VAC (Please refer to "TOTAL HARMONIC DISTORTION" section)		
EFFICIENCY (Typ.)	93%	94%	
AC CURRENT (Typ.)	1.3A / 230VAC	1.1A / 277VAC	
INRUSH CURRENT (Typ.)	COLD START 60A(twidth=600μs measured at 50% Ipeak) at 230VAC; Per NEMA 410		
MAX. NO. of PSUs on 16A CIRCUIT BREAKER	3 units (circuit breaker of type B) / 5 units (circuit breaker of type C) at 230VAC		
LEAKAGE CURRENT	<0.25mA / 277VAC		
STANDBY POWER CONSUMPTION	standby power consumption<0.5W (Dimming off)		
PROTECTION			
OVERLOAD	105~150%, hiccup mode, recovers automatically after fault condition is removed		
SHORT CIRCUIT	Blank type: Shut down O/P voltage, re-power on to recover after fault condition is removed DA2/DA2Q type:Hiccup mode, recovers automatically after fault condition is removed		
OVER VOLTAGE	27 ~ 36V	52 ~ 63V	
OVER TEMPERATURE	Shut down O/P voltage, re-power on to recover after fault condition is removed		
ENVIRONMENT			
WORKING TEMP.	Tcase=-20~+90°C (Please refer to " OUTPUT LOAD vs TEMPERATURE" section)		
MAX. CASE TEMP.	Tcase=90°C		
WORKING HUMIDITY	20 ~ 95% RH non-condensing		
STORAGE TEMP., HUMIDITY	-40 ~ +80°C, 10 ~ 95% RH		
TEMP. COEFFICIENT	±0.03%/°C (0 ~ 50°C)		
VIBRATION	5 ~ 100Hz, 2G 12min./1cycle, each along X,Y,Z axes according to EN50090-2-2		
SAFETY & EMC			
SAFETY STANDARDS	ENEC BS EN/EN61347-1, BS EN/EN61347-2-13(EL) appendix J suitable for emergency installations(DC input 176-280VDC), BS EN/EN62384; GB/T19510.1,GB/T19510.2,13; EAC TP TC 004; Design refer to AS/NZS 61347-1, AS/NZS 61347-2-13		
DALI STANDARDS	Comply with IEC62386-101, 102, 207(DT6),209(DT8),DALI Part 251		
WITHSTAND VOLTAGE	I/P-O/P: 3.75KVAC		
ISOLATION RESISTANCE	I/P-O/P:100M Ohms / 500VDC / 25°C/ 70% RH		
EMC EMISSION Note.4	Parameter	Standard	Test Level/Note
	Conducted	BS EN/EN55015(CISPR15), GB/T17743	-----
	Radiated	BS EN/EN55015(CISPR15), GB/T17743	-----
	Harmonic Current	BS EN/EN61000-3-2, GB 17625.1	Class C @load 50%
	Voltage Flicker	BS EN/EN61000-3-3	-----
EMC IMMUNITY	BS EN/EN61547		
	Parameter	Standard	Test Level/Note
	ESD	BS EN/EN61000-4-2	Level 3, 8KV air ; Level 2, 4KV contact
	Radiated	BS EN/EN61000-4-3	Level 2
	EFT/Burst	BS EN/EN61000-4-4	Level 2
	Surge	BS EN/EN61000-4-5	Level 4, 2KV/Line-Line
	Conducted	BS EN/EN61000-4-6	Level 2
	Magnetic Field	BS EN/EN61000-4-8	Level 2
	Voltage Dips and Interruptions	BS EN/EN61000-4-11:2020	30% dip 10 periods 100% interruption 0.5 periods
	OTHERS		
FLICKER Note.9	PstLM < 1, SVM < 0.4		
MTBF	1801.3K hrs min. Telcordia SR-332 (Bellcore); 155.5K hrs min. MIL-HDBK-217F (25°C)		
DIMENSION	380*38*28.5mm (L*W*H)		
PACKING	0.54Kg; 24 pcs/ 13.6 Kg/ 0.61 CUFT		
NOTE			
1. All parameters NOT specially mentioned are measured at 230VAC input, rated current and 25°C of ambient temperature.			
2. De-rating may be needed under low input voltages. Please refer to "STATIC CHARACTERISTIC" sections for details.			
3. Length of set up time is measured at first cold start. Turning ON/OFF the driver may lead to increase of the set up time.			
4. The driver is considered as a component that will be operated in combination with final equipment. Since EMC performance will be affected by the complete installation, the final equipment manufacturers must re-qualify EMC Directive on the complete installation again.			
5. This series meets the typical life expectancy of >50,000 hours of operation when Tcase, particularly Ⓞpoint (or TMP, per DLC), is about 75°C or less.			
6. Please refer to the warranty statement on MEAN WELL's website at http://www.meanwell.com			
7. The ambient temperature derating of 3.5°C/1000m with fanless models and of 5°C/1000m with fan models for operating altitude higher than 2000m(6500ft).			
8. It is not recommended to connect to capacitive loads.			
9. Flicker is measured at full load with the light source provided by MEAN WELL.			
10. RCM is on a voluntary basis. Non-IC classification independent LED control gear is not suitable for residential installations.			
11. Based on IEC 62386-101/102 DALI power on timing and interruption regulations, the set up time needs to test with a DALI controller which can support for DALI power on function, otherwise the set up time will be higher than 0.5 second for DA2 type.			
※ Product Liability Disclaimer : For detailed information, please refer to https://www.meanwell.com/serviceDisclaimer.aspx			

2.4 Mechanical Specification

2.4.1 SPWM-75 series

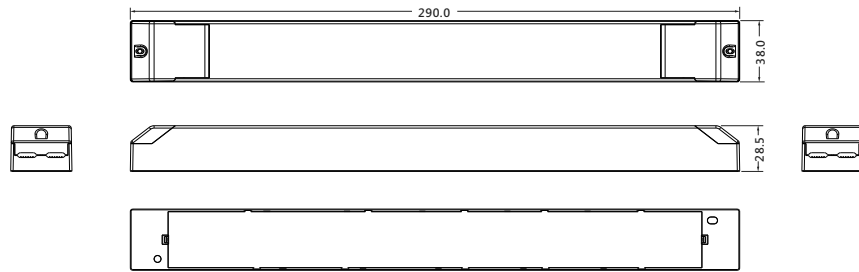

※ BLANK type

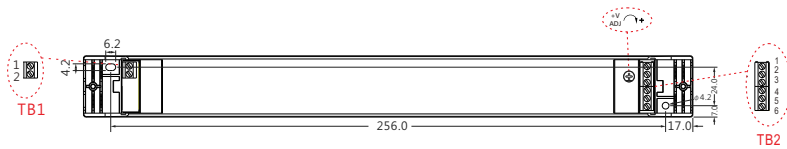

※ DA2 type

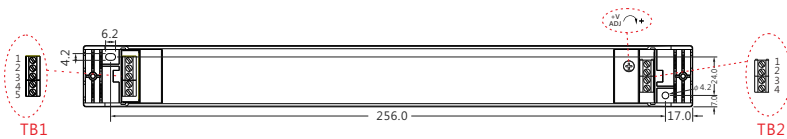

※ DA2Q type

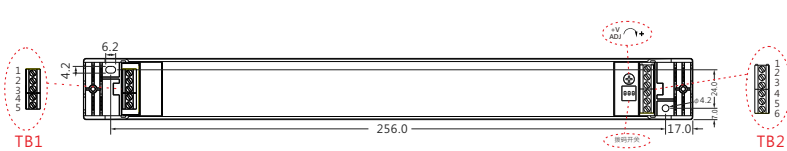

2.4.2 SPWM-150 series

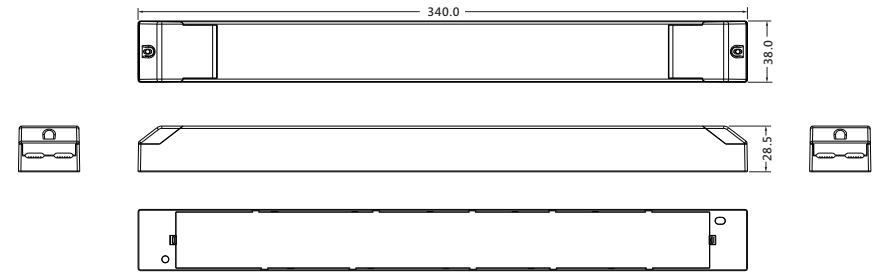

※ BLANK type

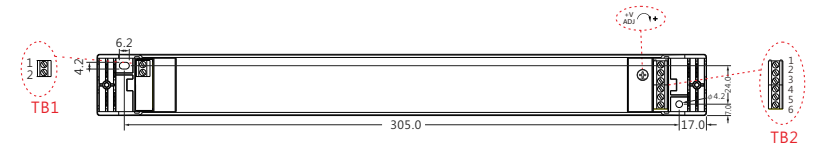

※ DA2 type

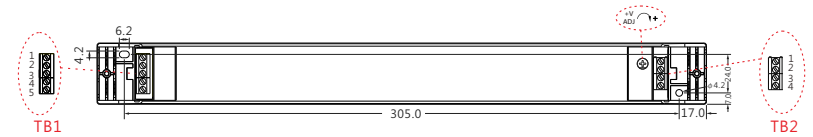

※ DA2Q type

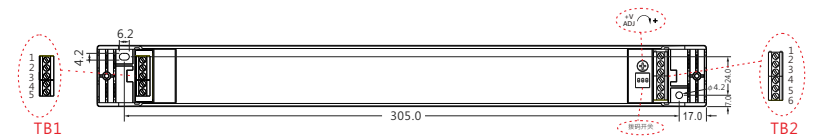

2.4.3 SPWM-240 series

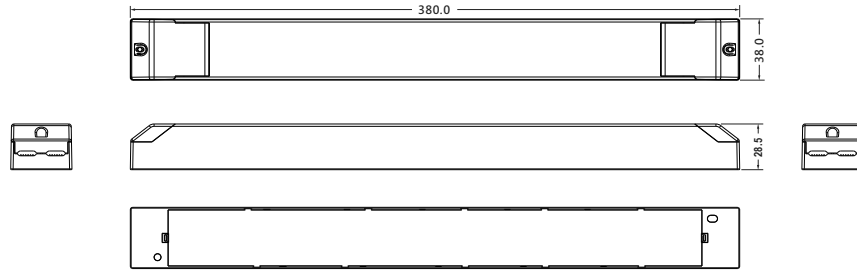

※ BLANK type

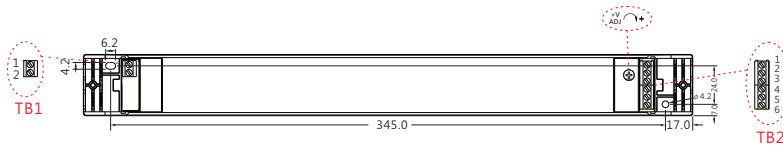

※ DA2 type

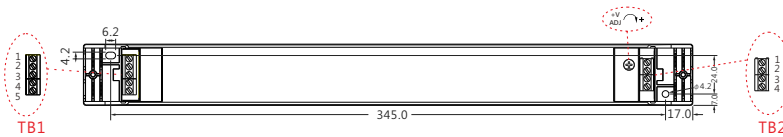

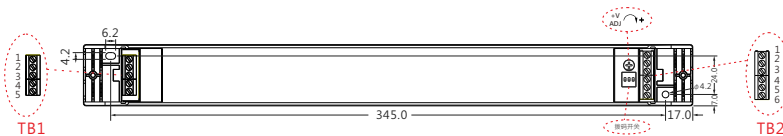

※ DA2Q type



2.5 Connecting Terminal

2.5.1 Terminal definition

Series	model	Terminal definition																													
SPWM-75 /150/240	BLANK type	 <table border="1" data-bbox="1556 395 1765 448"> <thead> <tr> <th>Terminal</th> <th>Pin No.</th> <th>Assignment</th> </tr> </thead> <tbody> <tr> <td rowspan="2">TB1</td> <td>1</td> <td>AC/L</td> </tr> <tr> <td>2</td> <td>AC/N</td> </tr> </tbody> </table> <table border="1" data-bbox="1832 395 2040 512"> <thead> <tr> <th>Terminal</th> <th>Pin No.</th> <th>Assignment</th> </tr> </thead> <tbody> <tr> <td rowspan="6">TB2</td> <td>1</td> <td>+V</td> </tr> <tr> <td>2</td> <td>+V</td> </tr> <tr> <td>3</td> <td>-V</td> </tr> <tr> <td>4</td> <td>-V</td> </tr> <tr> <td>5</td> <td>DIM+</td> </tr> <tr> <td>6</td> <td>DIM-</td> </tr> </tbody> </table>	Terminal	Pin No.	Assignment	TB1	1	AC/L	2	AC/N	Terminal	Pin No.	Assignment	TB2	1	+V	2	+V	3	-V	4	-V	5	DIM+	6	DIM-					
	Terminal	Pin No.	Assignment																												
	TB1	1	AC/L																												
2		AC/N																													
Terminal	Pin No.	Assignment																													
TB2	1	+V																													
	2	+V																													
	3	-V																													
	4	-V																													
	5	DIM+																													
	6	DIM-																													
DA2 type	 <table border="1" data-bbox="1556 639 1765 740"> <thead> <tr> <th>Terminal</th> <th>Pin No.</th> <th>Assignment</th> </tr> </thead> <tbody> <tr> <td rowspan="5">TB1</td> <td>1</td> <td>AC/L</td> </tr> <tr> <td>2</td> <td>AC/N</td> </tr> <tr> <td>3</td> <td>NC</td> </tr> <tr> <td>4</td> <td>DA+/PUSH</td> </tr> <tr> <td>5</td> <td>DA-/N</td> </tr> </tbody> </table> <table border="1" data-bbox="1832 639 2040 724"> <thead> <tr> <th>Terminal</th> <th>Pin No.</th> <th>Assignment</th> </tr> </thead> <tbody> <tr> <td rowspan="4">TB2</td> <td>1</td> <td>+V</td> </tr> <tr> <td>2</td> <td>+V</td> </tr> <tr> <td>3</td> <td>-V</td> </tr> <tr> <td>4</td> <td>-V</td> </tr> </tbody> </table>	Terminal	Pin No.	Assignment	TB1	1	AC/L	2	AC/N	3	NC	4	DA+/PUSH	5	DA-/N	Terminal	Pin No.	Assignment	TB2	1	+V	2	+V	3	-V	4	-V				
Terminal	Pin No.	Assignment																													
TB1	1	AC/L																													
	2	AC/N																													
	3	NC																													
	4	DA+/PUSH																													
	5	DA-/N																													
Terminal	Pin No.	Assignment																													
TB2	1	+V																													
	2	+V																													
	3	-V																													
	4	-V																													
DA2Q type	 <table border="1" data-bbox="1556 863 1765 963"> <thead> <tr> <th>Terminal</th> <th>Pin No.</th> <th>Assignment</th> </tr> </thead> <tbody> <tr> <td rowspan="5">TB1</td> <td>1</td> <td>AC/L</td> </tr> <tr> <td>2</td> <td>AC/N</td> </tr> <tr> <td>3</td> <td>PUSH/L</td> </tr> <tr> <td>4</td> <td>DA+/L</td> </tr> <tr> <td>5</td> <td>DA-/N</td> </tr> </tbody> </table> <table border="1" data-bbox="1832 863 2040 979"> <thead> <tr> <th>Terminal</th> <th>Pin No.</th> <th>Assignment</th> </tr> </thead> <tbody> <tr> <td rowspan="6">TB2</td> <td>1</td> <td>+V</td> </tr> <tr> <td>2</td> <td>+V</td> </tr> <tr> <td>3</td> <td>1/-R/C.W.</td> </tr> <tr> <td>4</td> <td>2/-G/W.W.</td> </tr> <tr> <td>5</td> <td>3/-B/C.W.</td> </tr> <tr> <td>6</td> <td>4/-W/W.W.</td> </tr> </tbody> </table> <p>Note: The DA2Q type has 4 channels of output. For detailed application settings, please refer to Chapter 3.</p>	Terminal	Pin No.	Assignment	TB1	1	AC/L	2	AC/N	3	PUSH/L	4	DA+/L	5	DA-/N	Terminal	Pin No.	Assignment	TB2	1	+V	2	+V	3	1/-R/C.W.	4	2/-G/W.W.	5	3/-B/C.W.	6	4/-W/W.W.
Terminal	Pin No.	Assignment																													
TB1	1	AC/L																													
	2	AC/N																													
	3	PUSH/L																													
	4	DA+/L																													
	5	DA-/N																													
Terminal	Pin No.	Assignment																													
TB2	1	+V																													
	2	+V																													
	3	1/-R/C.W.																													
	4	2/-G/W.W.																													
	5	3/-B/C.W.																													
	6	4/-W/W.W.																													

2.5.2 Wiring requirements

TB1 and TB2 terminal wiring requirements:

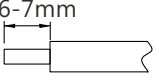
Terminal type	Wire	Stripping length	Suggested torque
M2.5 Screw	0.75~2.5mm ² (18~14AWG)	6-7mm 	0.4 N·m (3.5 Lb·in)

2.6 Installation

2.6.1 Installation method

Provide an example of the installation method for the DA2Q model.

① Gently flip up the protective cover.

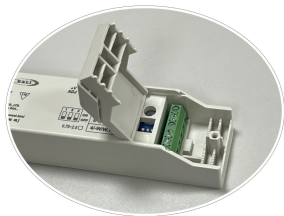

② Use a screwdriver, adjust the dip switch to set different application modes (see Chapter 3 DA2Q Model Application Setting Instructions for details).



③ Use a screwdriver to tighten the wire, with a suggested torque of 3.5 Lb-in.

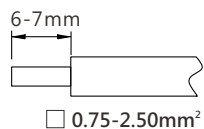
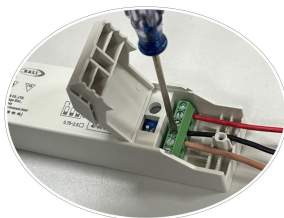

④ Close and tighten the protective cover with screws.



2.6.2 Installation precautions

(1) Do not stack and place products. The distance between products should be ≥ 15 cm to avoid affecting product heat dissipation and reducing service life.

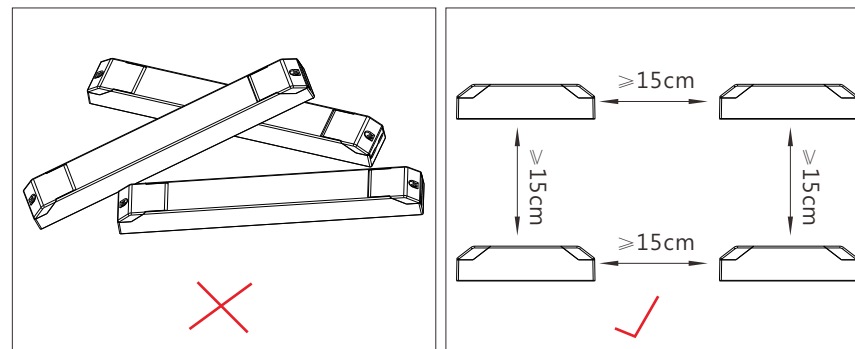

(2) When installing the product, a gasket of ≥ 7 mm should be added below the fixing screw to reserve a gap for effective heat dissipation and extend the product's service life.

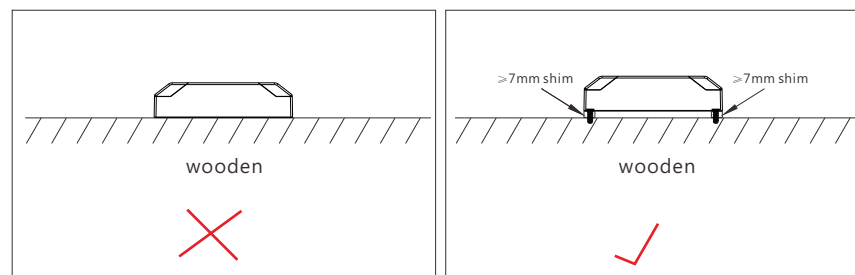

3.DA2Q Type Application Settings

The DA2Q type is a 4-channel output model that can be configured for various control modes via the built-in DIP switch. These devices support DALI-2 DT6 or DT8, and the detailed settings are shown in the table below. The sum of the output power of all channels must not exceed the rated power of the product.

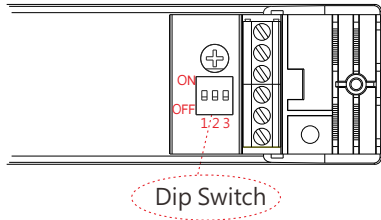

※ DALI interface(4 channels output, for DA2Q Model)

Dip Switch			Application	Output channels	Output connections schematic diagram
1	2	3			
ON	ON	ON	1 logic unit of LED (DT6, Brightness Dimming)	1 logical control gear 1 DALI address	
ON	ON	OFF	4 logic units of LED (DT6, Brightness Dimming)	4 logical control gears 4 DALI addresses	
OFF	OFF	OFF	1 logic unit of colour type RGBW (DT8, RGBW colour control) (factory default)	1 logical control gear 1 DALI address	
ON	OFF	OFF	1 logic unit of colour type Tc (DT8, Tunable white control)	1 logical control gear 1 DALI address	
OFF	ON	OFF	2 logic units of colour type Tc (DT8, Tunable white control)	2 logical control gears 2 DALI addresses	
OFF	OFF	ON	2 logic units (1 logic unit of DT6) (1 logic unit of colour type Tc)	2 logical control gears 2 DALI addresses	

4.Dimming Operation

4.1 Dimming principle

4.1.1 Dimming principle for PWM style output(1 channel output, for BLANK/DA2 Type)

-Dimming is achieved by varying the duty cycle of the output current.

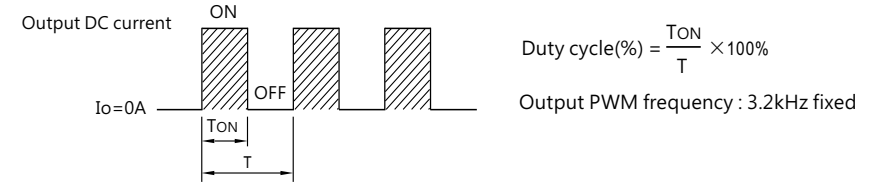

4.1.2 Dimming principle for colour temperature dimming and brightness dimming (4 channels output, for DA2Q Type)

Note: The sum of the 4 channels power cannot exceed the product's rated power.

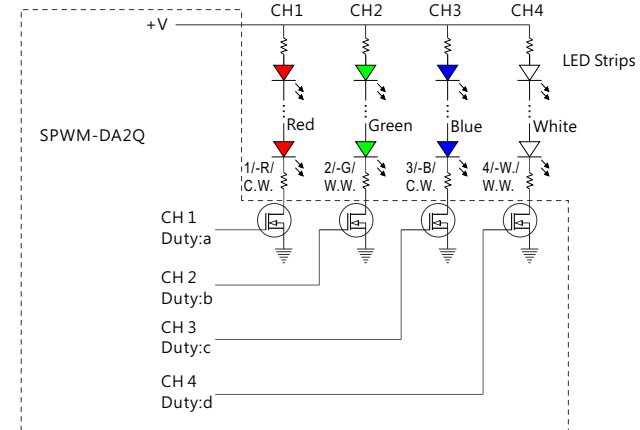

(1) According to the DALI IEC 62386-209 regulation, there are two types of colour control: normalised colour control and extended colour control. Users can set the product to normalised or extended colour control mode by sending corresponding DALI commands. The DALI command is described as follows:

10.6.13.5 Changes to 11.3.4.1 A application extended control commands
 Command 237: YAAA AAA1 1110 1101 "SET TEMPORARY RGBWAF CONTROL"
 This command shall be discarded for DTR0 values other than 0x80 and 0xC0. The data in DTR0 shall be stored as 'TEMPORARY RGBWAF CONTROL' .
 The data in DTR0 shall be interpreted as:
 bit 0-5 Reserved; shall be '0'
 bits 7..6 control type;
 ○ '00' = Reserved
 ○ '01' = Reserved
 ○ '10' = Normalised colour control
 ○ '11' = Extended colour control

(2) The following is an explanation of the differences between normalised colour control mode and extended colour control mode for the SPWM-240-24DA2Q product:
 The output load is an RGBW LED strip with a length of 10 meters and a rated parameter of 24V/240W, assuming that the power of each colour (R/G/B/W) is 60W, as shown in the figure below.

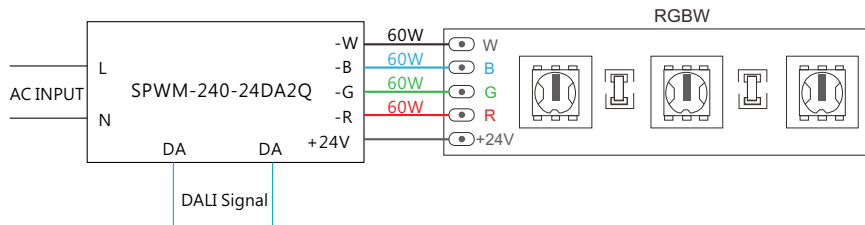

※ When SPWM-240-24DA2Q is set to the normalised colour control mode (factory default)
 Under the normalised colour control mode, the sum of duty cycles of the four output channels is $\leq 100\%$ (this limitation is defined by the DALI IEC 62386-209 regulation).
 If the above load conditions are followed, the total luminous power of the LED strip is $\leq 60W$. When the length of the LED strip is extended to 40 meters, the output power can reach 240W.

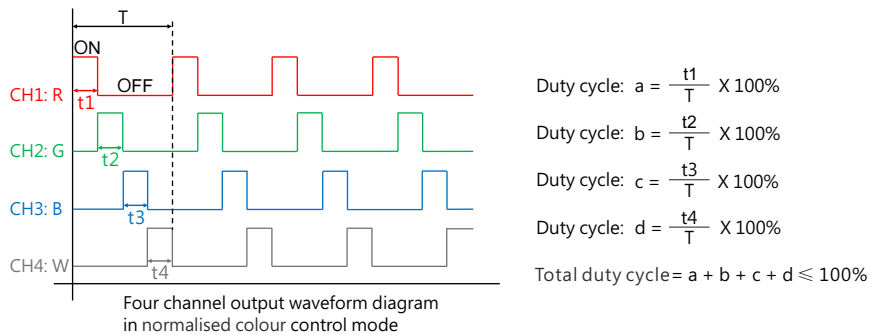

※ When SPWM-240-24DA2Q is set to extended colour control mode (set through DALI command)
 Under the extended colour control mode, the sum of duty cycles of the four output channels is $\leq 400\%$ (this limitation is defined by the DALI IEC 62386-209 regulation).
 If the above load conditions are followed, the total luminous power of the LED strip is $\leq 240W$.

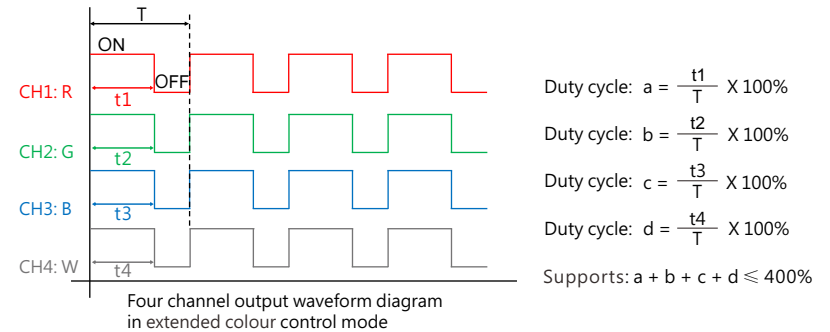

In conclusion,

1. With RGBW LED strips of the same length and specifications, the extended colour control mode outputs higher power compared to the normalised colour control mode, which means that the LED strip brightness will be higher.
2. With RGBW LED strips of the same specifications, the length of LED strip that can be driven by the SPWM Series DA2Q driver in normalised colour control mode is four times as long as that in extended colour control mode.
3. Whether in normalised colour control or extended colour control mode, the sum of the output power of the 4 channels shall not exceed the rated power of the product at any moment, as shown below:

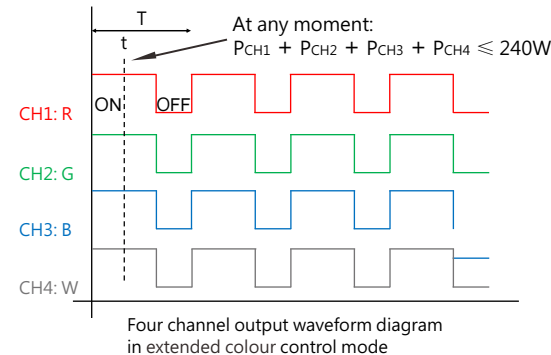
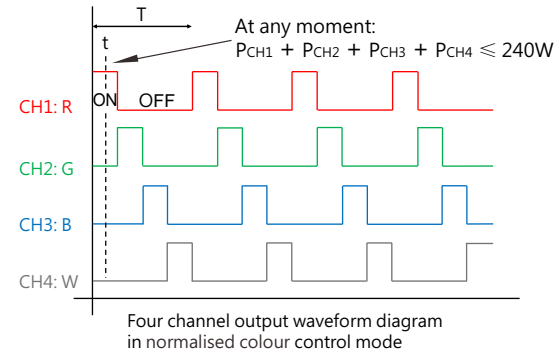

4.2 Three in one dimming function

- ※ Output constant current level can be adjusted by applying one of the three methodologies between DIM+ and DIM-: 0~ 10VDC, or 10V PWM signal or 0~100KΩ resistance.
- ※ Direct connecting to LEDs is suggested. It is not suitable to be used with additional drivers.
- ※ Dimming source current from power supply: 100uA(typ.).
- ※ Min. dimming level is about 6% and the output current is not defined when $0\% < I_{out} < 6\%$
- ※ The output current could drop down to 0% when dimming input is about 0Ω or 0Vdc, or 10V PWM signal with 0% duty cycle.

◎ Applying additive 0~10VDC

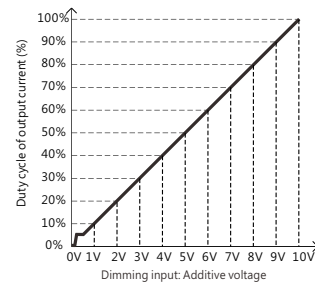
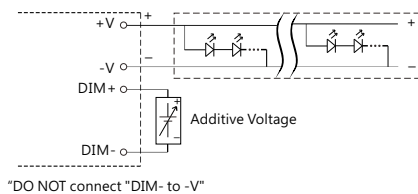

◎ Applying additive 10V PWM signal (frequency range 300Hz~3KHz):

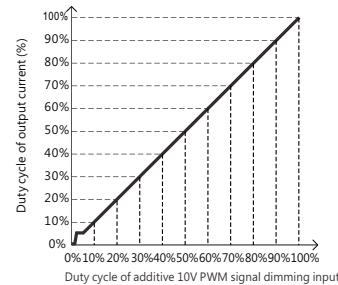
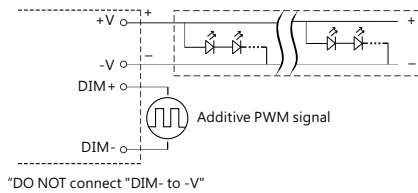

◎ Applying additive resistance: 0~100kΩ

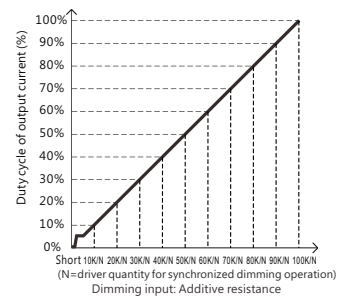
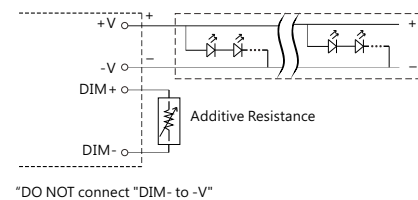

4.3 Push dimming

By using a reset switch, short or long push the switch can control the on/off of lights, as well as adjust brightness, colour temperature, and colour, etc.



- The factory default dimming level is at 100%.
- Up to 10 drivers can perform the PUSH dimming at the same time when utilizing one common push button.
- The maximum length of the cable from the push button to the last driver is 20 meters.

Action	Action duration
Short Push	0.1~1s
Long Push	> 1s

4.3.1 DA2 type push dimming instructions

※ Input wiring diagram :

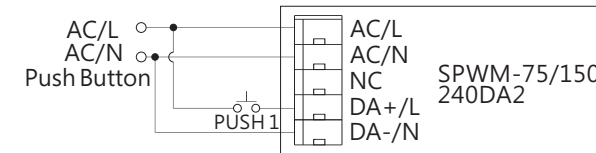

※ Functional description :

Model	Application	Push 1 for brightness
DA2 Type	1 logic unit of LED (DT6, Brightness Dimming)	<p>Short Push : ON/OFF</p> <p>Long Push : Dim up/down.</p> <ul style="list-style-type: none"> - dim up stop at maximum; dim down stop at minimum dim (not dim off) - with next push, direction change(up/down) - dim up possible even if when unit is OFF

4.3.2 DA2Q type push dimming instructions

※ Input wiring diagram :

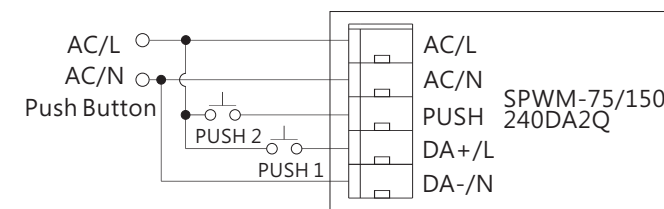

※ Input wiring diagram :

Model	Application	Dip Switch			Push 1 for brightness	Push 2 for colour
		1	2	3		
DA2Q Type	1 logic unit of LED (DT6, Brightness Dimming)	ON	ON	ON	Short Push : ON/OFF Long Push : Dim up/down. - dim up stop at maximum; dim down stop at minimum dim (not dim off) - with next push, direction change(up/down) - dim up possible even if when unit is OFF	Short Push : no response Long Push : no response
	4 logic unit of LED (DT6, Brightness Dimming)	ON	ON	OFF	4 control gears are synchronously controlled Short Push : ON/OFF Long Push : Dim up/down. - dim up stop at maximum; dim down stop at minimum dim (not dim off) - with next push, direction change(up/down) - dim up possible even if when unit is OFF	Short Push : no response Long Push : no response
	1 logic unit of colour type RGBW (DT8, RGBW colour control) (factory default)	OFF	OFF	OFF	Short Push : ON/OFF Long Push : Dim up/down. - dim up stop at maximum; dim down stop at minimum dim (not dim off) - with next push, direction change(up/down) - dim up possible even if when unit is OFF	Short Push : Switch to "W channel control" or "RGB color control". Long Push : Dimming "W channel control" or "RGB color control". -W channel control: Long press to dim up stop at maximum. Long press to dim down stop at minimum(0). -RGB color control: Long press to change RGB color.
	1 logic unit of colour type Tc (DT8, Tunable white control)	ON	OFF	OFF	Short Push : ON/OFF Long Push : Dim up/down - dim up stop at maximum; dim down stop at minimum dim (not dim off) - with next push, direction change(up/down) - dim up possible even if when unit is OFF	Short Push : ON/OFF Long Push : Dim2Warm - The color temperature warms up while the brightness dims, and the color temperature cools down while the brightness brightens. - dim up stop at maximum; dim down stop at minimum dim (not dim off) - with next push, direction change (up,cooler/down,warm) - dim up possible even if when unit is OFF
	2 logic units of colour type Tc (DT8, Tunable white control)	OFF	ON	OFF	2 control gears are synchronously controlled Short Push : ON/OFF Long Push : Dim up/down - dim up stop at maximum; dim down stop at minimum dim (not dim off) - with next push, direction change(up/down) - dim up possible even if when unit is OFF	2 control gears are synchronously controlled Short Push : ON/OFF Long Push : Dim2Warm - The color temperature warms up while the brightness dims, and the color temperature cools down while the brightness brightens. - dim up stop at maximum; dim down stop at minimum dim (not dim off) - with next push, direction change (up,cooler/down,warm) - dim up possible even if when unit is OFF
2 logic units (1 logic unit of DT6) (1 logic unit of colour type Tc)	OFF	OFF	ON	Only the DT6 device responds Short Push : ON/OFF Long Push : Dim up/down - dim up stop at maximum; dim down stop at minimum dim (not dim off) - with next push, direction change(up/down) - dim up possible even if when unit is OFF	Only the DT8 device responds Short Push : ON/OFF Long Push : Dim2Warm - The color temperature warms up while the brightness dims, and the color temperature cools down while the brightness brightens. - dim up stop at maximum; dim down stop at minimum dim (not dim off) - with next push, direction change (up,cooler/down,warm) - dim up possible even if when unit is OFF	

5.DALI-2 System Application

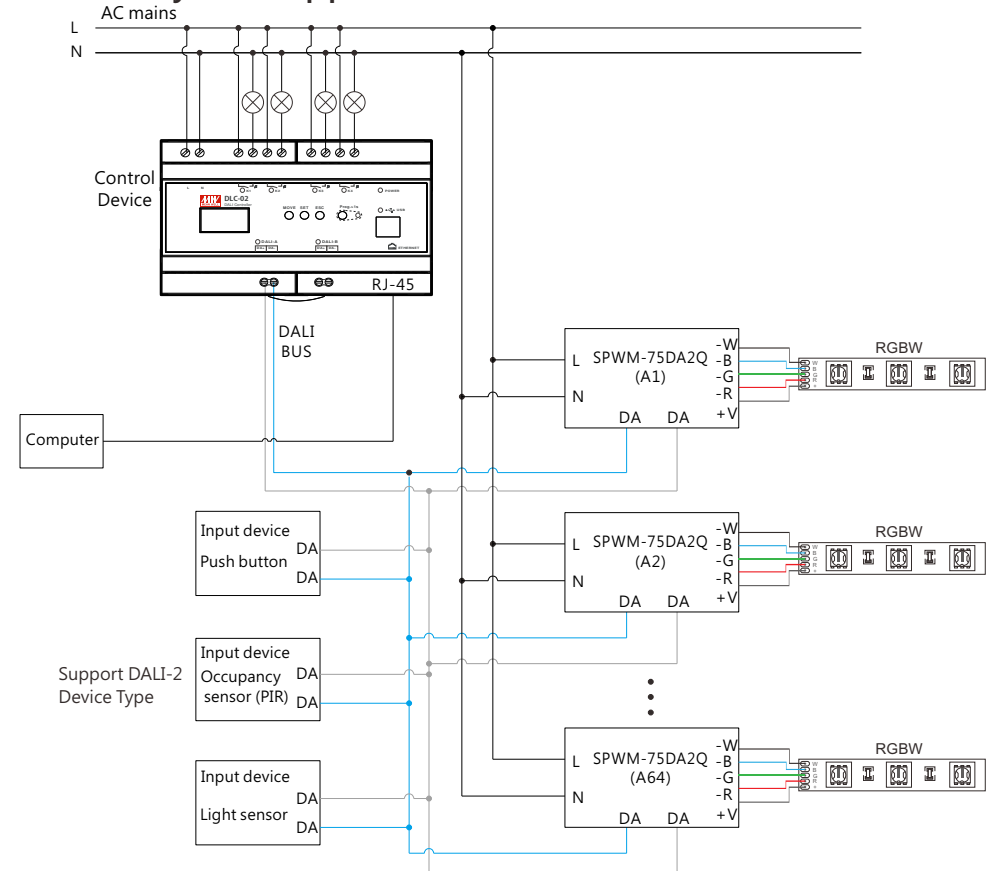

DALI-2 digital lighting system configuration diagram

MEAN WELL DLC-02 is a DALI-2 application controller with built-in 2-channel DALI bus power supply. Each DALI bus can connect up to 12 input devices and 64 LED drivers. The SPWM series DALI-2 LED driver, combined with DLC-02 controller and input devices (such as touch panel DTP-2XX series and PIR motion sensor DLS-2XX series), forms the DALI-2 digital lighting system. By using PC software to scan input devices and lighting fixtures on the DALI bus and configure parameters and effects, it is possible to control the on/off, brightness, color, group, scene, and various events of DALI lighting fixtures, meeting daily lighting control needs.

Here is the relevant reference material link:

DLC-02 Manual:

<https://www.meanwell.com/Upload/PDF/DLC-02-E.pdf>

DLC-02 PC software :



<https://www.meanwell.com/Upload/PDF/DLC-02/DLC-02-SOP-E.pdf>

6.Application Examples

6.1 SPWM-DA2Q and touch panel example

Taking poster lightbox lighting as an example, there are four 24V/100W adjustable colour temperature poster lightboxes (LED 1~LED 4) in the exhibition hall, divided into two groups. The brightness and colour temperature changes of these two groups' lights are controlled by touch panel.

In this example, two SPWM-240-24DA2Q can be used, each set as 2 sets of colour temperature control channels, for a total of 4 sets of channels to independently control LED1~LED4.



(1) MEAN WELL DALI-2 Devices and Application Software

- A · Two DALI-2 24V constant voltage LED drivers, model: SPWM-240-24DA2Q
- B · One 3-buttons DALI-2 touch panel, model: DTP-203-E
- C · One DALI-2 controller, model: DLC-02
- D · DLC-02 PC software



Note: For wiring diagram, please refer to the instructions in Chapter 5.

(2) SPWM-240-24DA2Q dip switch setting

Set SPWM-240-24DA2Q as 2 logic units of colour type Tc according to the following dip switch settings.

Dip Switch			Application	Output channels	Output connections schematic diagram																		
1	2	3																					
OFF	ON	OFF	2 logic units of colour type Tc (DT8, Tunable white control)	2 control gears 2 DALI addresses	<table border="1"> <thead> <tr> <th colspan="6">Output Terminal</th> </tr> </thead> <tbody> <tr> <td>4/-W/ W.W.</td> <td>3/-B/ C.W.</td> <td>2/-G/ W.W.</td> <td>1/-R/ C.W.</td> <td>+V</td> <td>+V</td> </tr> <tr> <td colspan="6"> </td> </tr> </tbody> </table>	Output Terminal						4/-W/ W.W.	3/-B/ C.W.	2/-G/ W.W.	1/-R/ C.W.	+V	+V						
Output Terminal																							
4/-W/ W.W.	3/-B/ C.W.	2/-G/ W.W.	1/-R/ C.W.	+V	+V																		

(3) Lamps grouping settings

- A · LED 1~2 : Group 1
- B · LED 3~4 : Group 2
- C · LED 1~4 : Group 3

(4) Effect Settings



Button No	Controlled object	Trigger Mode	Effect Description
1	Group 1	Short press	On (brightness 100%/colour temperature 6500K)/Off (0%)
		Double press	Brightness 100%/colour Temperature 2700K
		Long press	Adjust colour temperature
2	Group 2	Short press	On (brightness 100%/colour temperature 6500K)/Off (0%)
		Double press	Brightness 100%/colour Temperature 2700K
		Long press	Adjust colour temperature
3	Group 3	Short press	On (brightness 100%/colour temperature 6500K)/Off (0%)
		Double press	Brightness 100%/colour Temperature 2700K
		Long press	Adjust colour temperature

(5) The implementation steps are as follows (Steps 1 to 3 can be configured offline, and Steps 4 to 5 require connecting to DALI devices for online operation):

Step 1: Set parameters such as virtual lamp type, group, and fade time

In the "Installation" interface of the DLC-02 software, DALI parameters for lamps and input devices can be set.

Operation Details:

- Select LED 1 under virtual lamp, set the colour type to Colour TC, and set the fade time to 2 seconds.
- Click Bus Group Set - Edit, check Group 1 and Group 3, and click Save to complete the setting.
- Using the same method: For LED 2, LED 3, and LED 4, set the colour type to Colour TC and the fade time to 2 seconds. Add LED 2 to Group 1 and Group 3. Add LED 3 and LED 4 to Group 2 and Group 3.

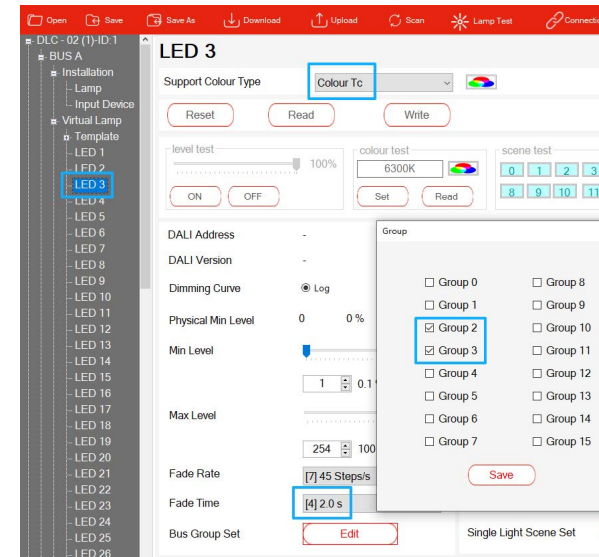
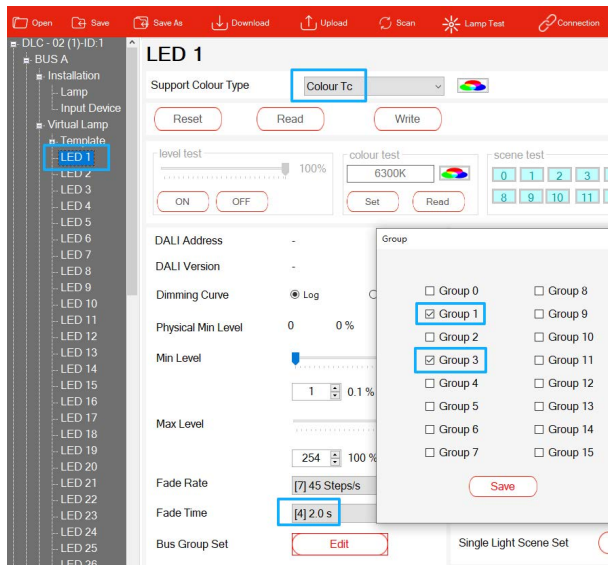

Step 2: Add and configure virtual input device instances

✖Add input device instances

Select Device 1 under virtual input device. You can customize its name to "DTP-203-E Touch Panel". This virtual input device defaults to button sensor type with 1 button instance. Right-click on the blank area of the instance table, select "+Add", and add 2 more button instances.

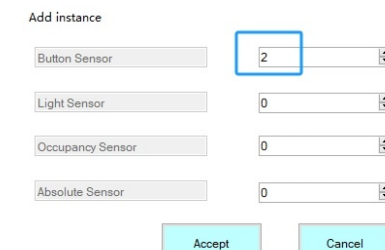
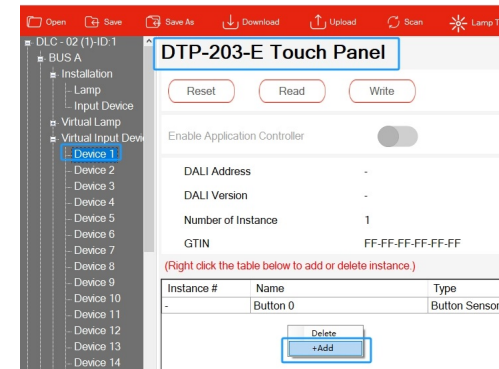

※Configure the input device instance

Rename the three buttons as **Button 1**, **Button 2**, and **Button 3** (corresponding to the three physical buttons on the DTP-203-E). Check **Enable** for all buttons to activate them. Then click the **Setting** option to configure the button functions.

Instance #	Name	Type	Enable	Setting
-	Button 1	Button Sensor	<input checked="" type="checkbox"/>	Setting
-	Button 2	Button Sensor	<input checked="" type="checkbox"/>	Setting
-	Button 3	Button Sensor	<input checked="" type="checkbox"/>	Setting

As shown in the figure below, check the event filters related to "Short Press", "Double Click" and "Long Press", and set the event timer.

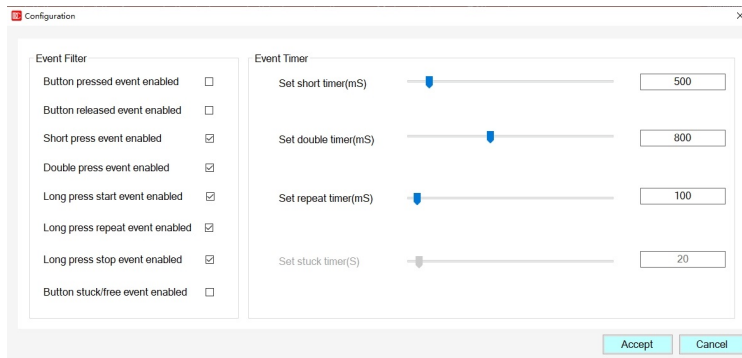

Note: For parameter descriptions of the input device, please refer to Section 4.3.3.4 of the DLC-02 Manual.

Step 3: Effect Configuration

The control logic between input devices (buttons) and lamp groups will be configured in the "Effects" interface. Click "+Add" to create an effect:

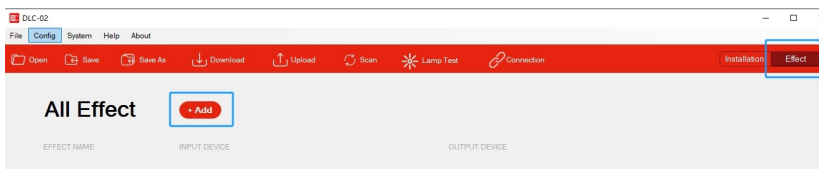

Rename the effect as "Button1 Controls Group1", and move "Button 1" in the input area and "Bus A Group 1" in the output area to the right selection area.

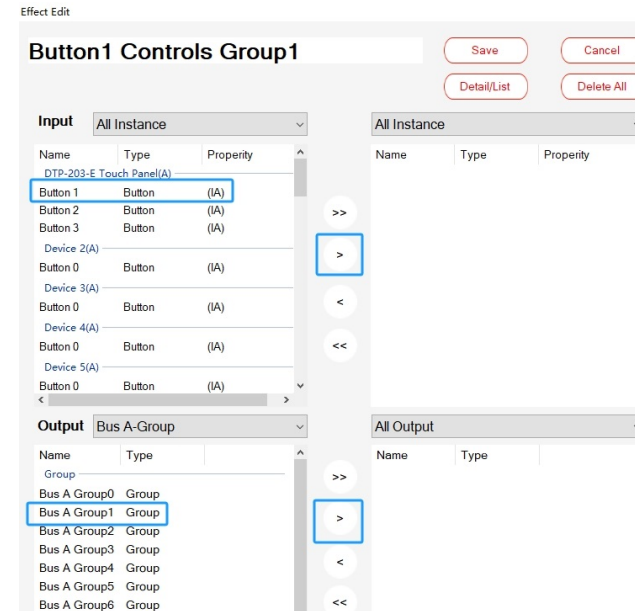

Select "Button 1", Select the colour mode as "Colour temperature" and under the "Lamp/Group" section:

- For "Short Push": Select "Toggle(Level/Tc and OFF)" and set the level to "100%" and set the Colour temperature to "6500K".
- For "Long Push": Select "Change Tc".
- For "Double Push": Select "Go to Level and Tc" and set the level to "100%" and set the Colour temperature to "2700K".

Click "Save" to complete the configuration of the control effect between "Button 1" and "Bus A Group 1".

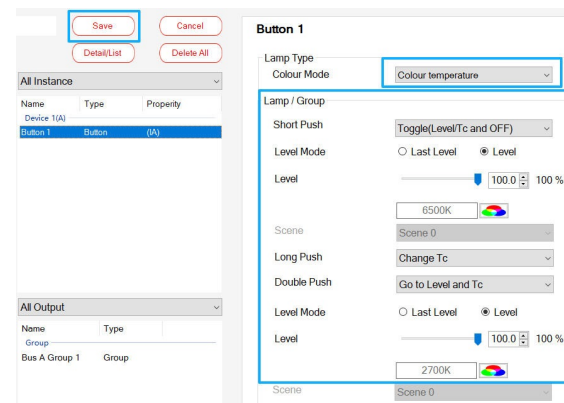

Continue to add two more effects. Refer to the configuration method for Button 1 above to complete the configuration of the control effects for "Button 2" and "Bus A Group 2", as well as "Button 3" and "Bus A Group 3".

A total of three effects will be configured, as shown in the figure below:

All Effect			+ Add		
EFFECT NAME	INPUT DEVICE	OUTPUT DEVICE			
Button1 Controls Group1	Button 1 :	Bus A Group 1 :	🔄	✎	🗑️
Button2 Controls Group2	Button 2 :	Bus A Group 2 :	🔄	✎	🗑️
Button3 Controls Group3	Button 3 :	Bus A Group 3 :	🔄	✎	🗑️

Step 4: Pair Virtual Lamps and Input Devices with Actual Lamps and Input Devices

※Device Scanning

Connect the two SPWM-240-24DA2Q LED drivers and one DTP-203-E input device in the conference room to the DALI-A bus of the DLC-02, then power on the AC supply. Use a USB cable to connect the computer to the USB port of the DLC-02.

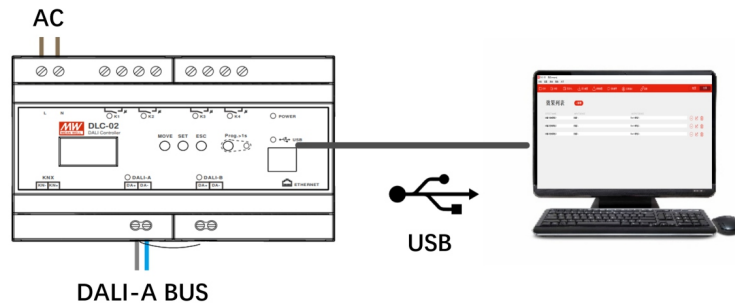

On the DLC-02 PC software, click "Connection" to establish communication between the computer and the DLC-02.

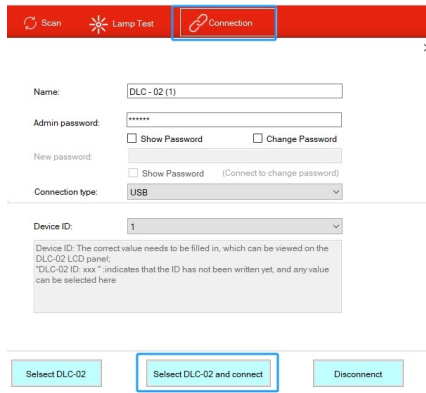

Then click "Scan – New Initialization" to scan for DALI devices online.

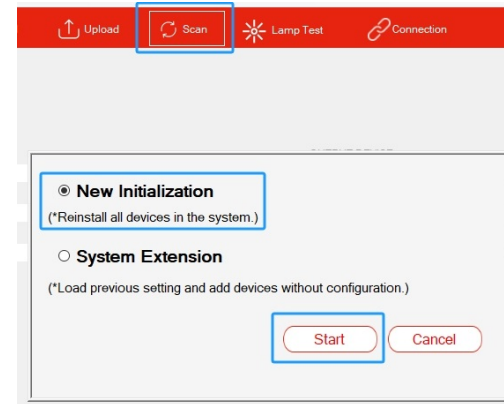

※Pair Virtual Lamps with Actual Lamps:

After device scanning is completed, click "Bus A - Installation - lamp". There are 4 Lamps on DALI Bus A. Select a lamp by its DALI address and click "Flash" for testing to locate the actual position of the lamp.

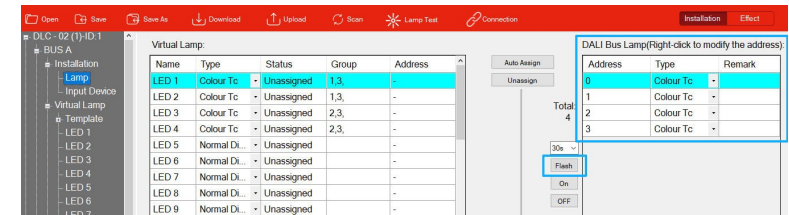

According to the actual positions of the lamps, use the mouse to select the DALI lamps on the right area, and drag them to the corresponding positions of the Virtual Lamp on the left area to complete the pairing.

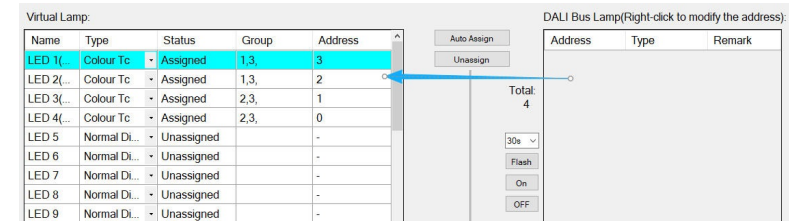

※Pairing Virtual Input Devices with Actual Input Devices

After completing device scanning, click "Bus A - Installation - Input Device". There is 1 input device on DALI Bus A. Select the device, and 3 button instances of the device will be displayed in the lower-right corner.

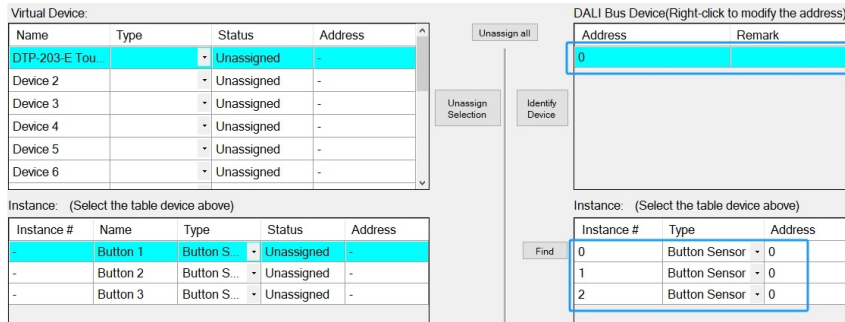

Use the mouse to select the instance number on the right area and drag it to the Virtual Device Instance position on the left area to complete the button pairing.

Instance 1, Instance 0, and Instance 2 are paired with Button 1, Button 2, and Button 3 respectively.

Note: For the button instance numbering table of DTP-203-E, please refer to Section 2.5.1.

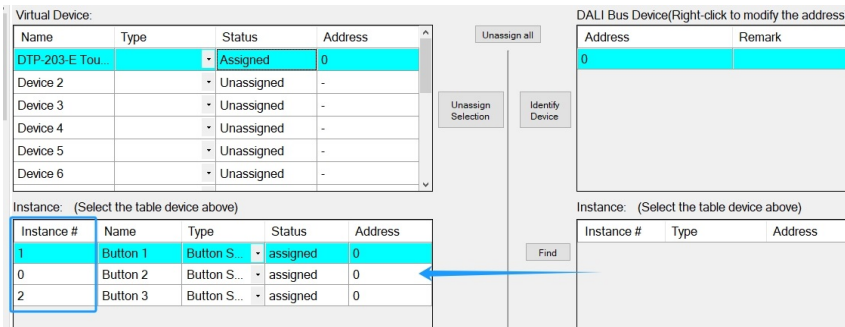

Step 5: Finally, click "Download – Device Parameter and Effect" to download all device parameters and effect configurations to the lamps, input devices, and the DLC-02 controller. After the download is complete, you can use the DTP-203-E touch panel to control these poster lightboxes.

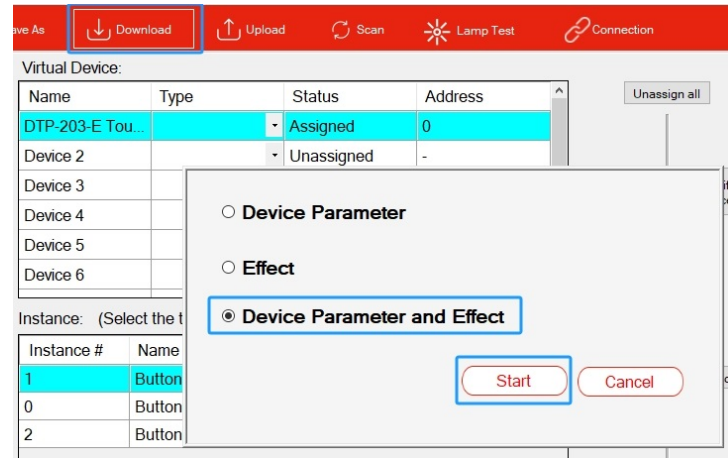

6.2 SPWM-DA2Q and PIR motion sensor example

Taking office lighting as an example, there are two 12V/60W strip lights (LED 1 and LED 2) and one PIR motion sensor in the pantry. When the PIR motion sensor detects someone coming, it will automatically turn on the lights, and when the person leaves, it will automatically turn off the lights to save energy. In this example, one SPWM-150-12DA2Q can be used and set as 4 sets of DT6 control channels, with 2 channels controlling LED1 and LED2.

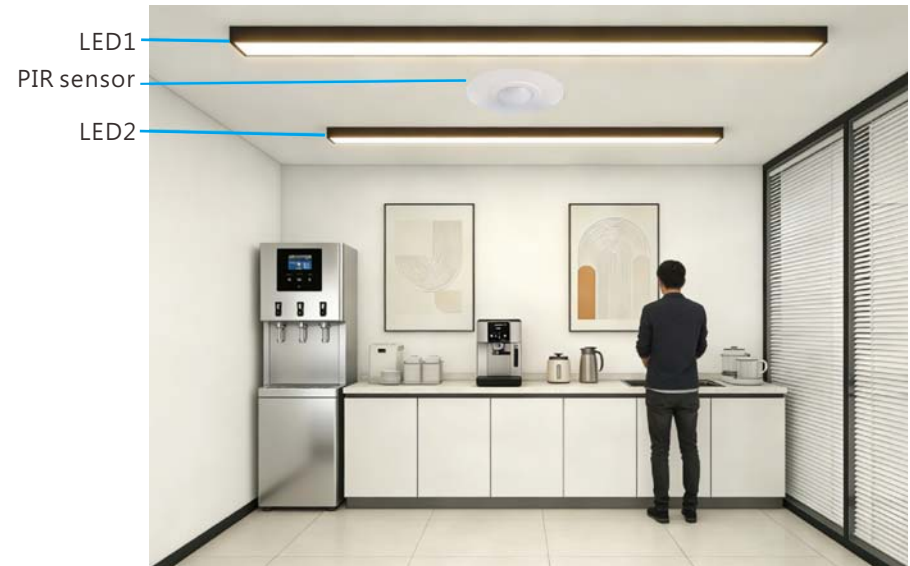

(1) MEAN WELL DALI-2 Devices and PC Software

- A · One DALI-2 12V constant voltage LED drivers, model: SPWM-150-12DA2Q
- B · One DALI-2 controller · model : DLC-02
- C · One DALI-2 PIR motion sensor · model : DLS-203-P
- D · DLC-02 PC software



(2) SPWM-150-12DA2Q dip switch setting

Set SPWM-150-12DA2Q as 4 logic unit of LED according to the following dip switch settings.

Dip Switch			Application	Output channels	Output connections schematic diagram																		
1	2	3																					
ON	ON	OFF	4 logic units of LED (DT6, Brightness Dimming)	4 control gears 4 DALI addresses	<table border="1" style="margin-left: auto; margin-right: auto;"> <thead> <tr> <th colspan="6">Output Terminal</th> </tr> <tr> <th>4/-W/ W.W.</th> <th>3/-B/ C.W.</th> <th>2/-G/ W.W.</th> <th>1/-R/ C.W.</th> <th>+V</th> <th>+V</th> </tr> </thead> <tbody> <tr> <td colspan="6" style="text-align: center;"> </td> </tr> </tbody> </table>	Output Terminal						4/-W/ W.W.	3/-B/ C.W.	2/-G/ W.W.	1/-R/ C.W.	+V	+V						
Output Terminal																							
4/-W/ W.W.	3/-B/ C.W.	2/-G/ W.W.	1/-R/ C.W.	+V	+V																		

(3) Lamps grouping settings

A. LED1~2 : Group 1

(4) Effect Settings



Trigger Mode	Controlled Object	Effect Description
Human movement detected	Group1	Turn on lights at 100% brightness for 5 minutes.
No human movement detected	Group1	Turn off after 30s delay.

(4) The implementation steps are as follows (Steps 1 to 3 can be configured offline, and Steps 4 to 5 require connecting to DALI devices for online operation)

Step 1: Set parameters such as virtual lamp type, group, and fade time
In the "Installation" interface of the DLC-02 software, you can set the DALI parameters for lamps and input devices.

Operation Details:

- Select LED 1 under virtual lamp, set the colour type to Normal Dimming and set the fade time to 2 seconds.
- Click Bus Group Set-Edit, check Group 1 and click Save to complete the setting.
- Use the same method to set LED2's colour type to Normal Dimming and fade time to 2 seconds, then add LED2 to Group 1.

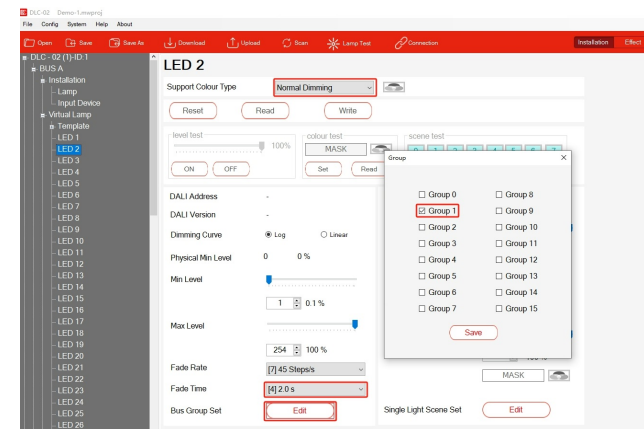
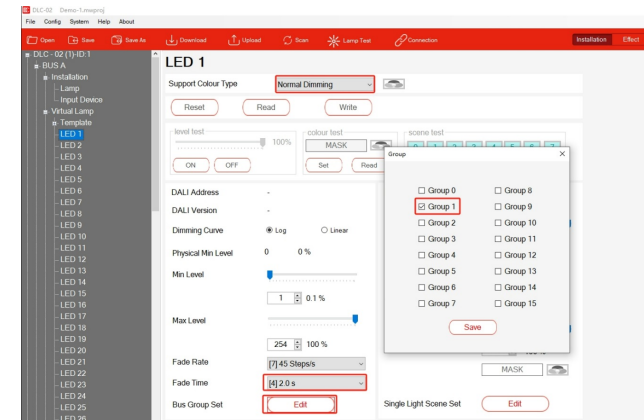

Step2: Add and configure virtual input device instances

※Add input device instances

Select "Device 1" under the Virtual Input Device, then customize its name to "DLS-203-P PIR sensor".

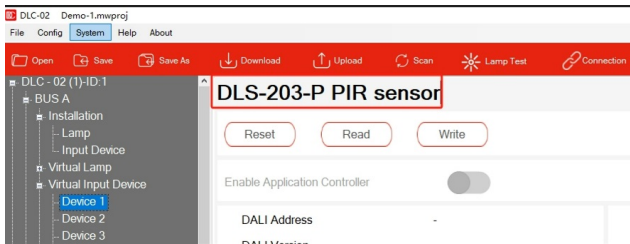

The system has a default "Button Sensor". Select it, right-click, and delete it.

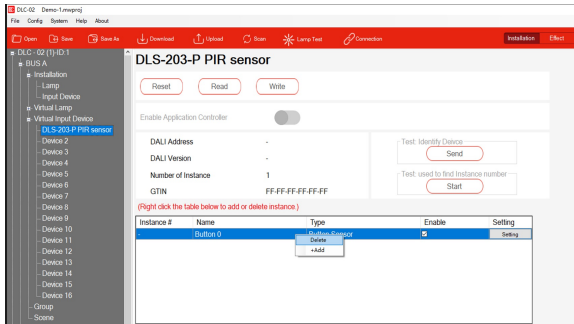

Right-click on the blank area of the instance table, select "+Add", then set the quantity of "Occupancy Sensor" to 1 and click Confirm.

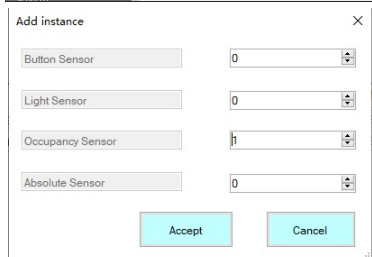
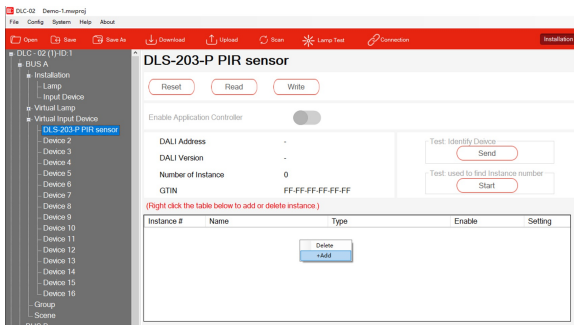

※Configure the input device instance

After adding, rename it to "Occupancy Sensor 1", check "Enable", then click the "Settings" button.

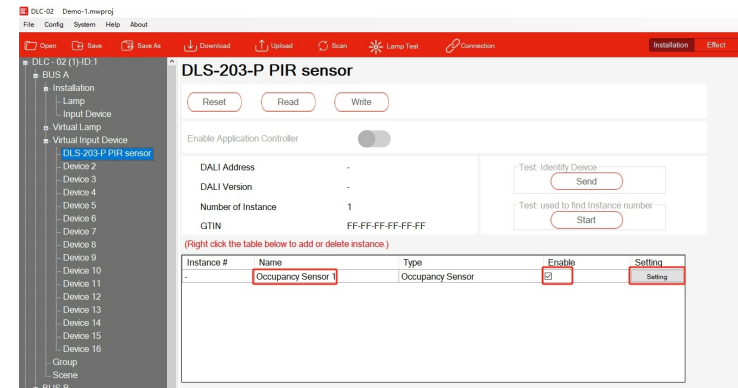

As shown in the figure below, check the Event filter related to "Occupied" and "Vacant", and set the Event Timer.

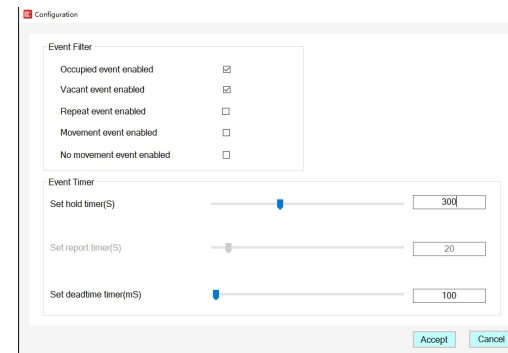

Note: For parameter descriptions of the input device, please refer to Section 4.3.3.4 of the DLC-02 Manual.

Step 3: Effect Configuration

The control logic between input devices (PIR Sensor) and lamp groups will be configured in the "Effects" interface. Click "+Add" to create an effect.



Rename "Effect 0" as "Sensor1 Controls Group1", and move "Occupancy Sensor1" in the input area and "BUS A Group1" in the output area to the right selection area.

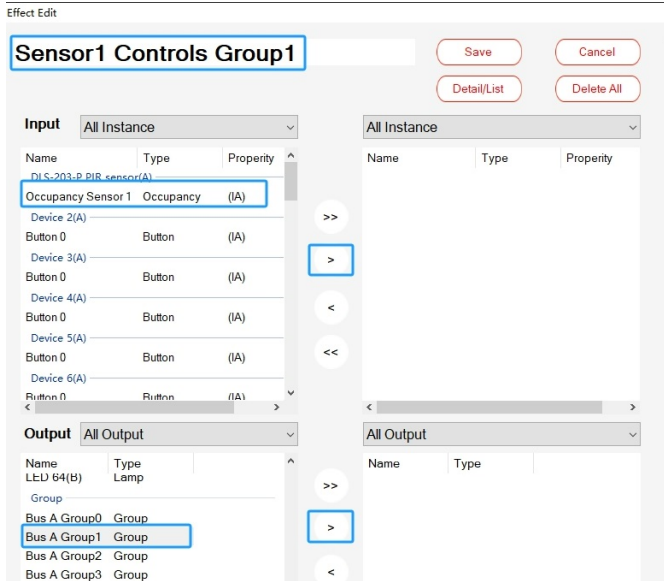

Then select "Occupancy Sensor 1", in the "Lamp/Group" section on the right, set the occupied Event Action to "Go to Level" and the brightness level to 100%; set the Vacant Event Action to "OFF" and the Delay Time to 30s. Click the Save button to complete the configuration of the control effect between "Occupancy Sensor 1" and "Bus A Group 1".

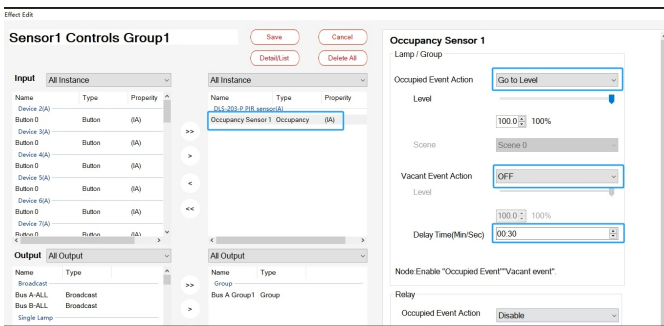

After completion, the effect list can be seen as follows.

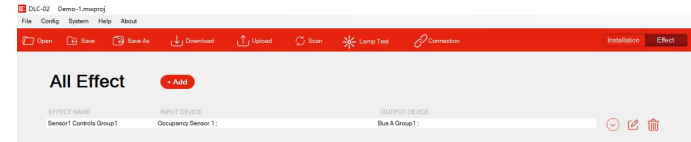

Step 4: Pair Virtual Lamps and Input Devices with Actual Lamps and Input Devices

✖Device Scanning

Connect the one SPWM-150-12DA2Q LED driver and one DLS-203-P input device in the pantry to the DALI-A bus of the DLC-02, then power on the AC supply. Use a USB cable to connect the computer to the USB port of the DLC-02.

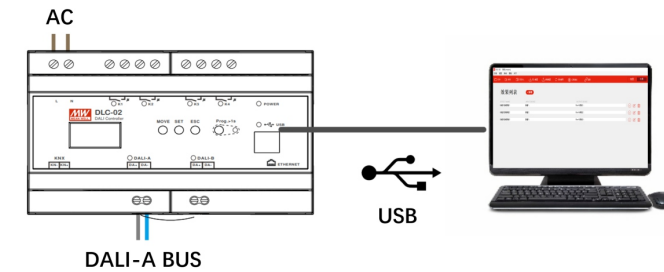

On the DLC-02 PC software, click "Connection" to establish communication between the computer and the DLC-02.

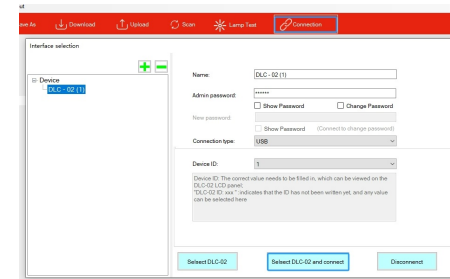

Then click "Scan - New Initialization" to scan for DALI devices online.

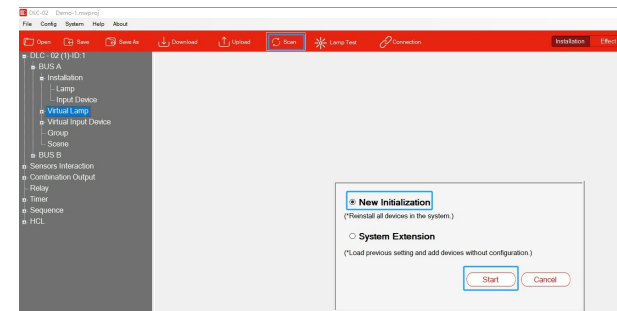

※Pair Virtual Lamps with Actual Lamps:

After device scanning is completed, click "Bus A - Installation - Lamp". There are 4 Lamps on DALI Bus A. Select a lamp by its DALI address and click "Flash" for testing to locate the actual position of the lamp.

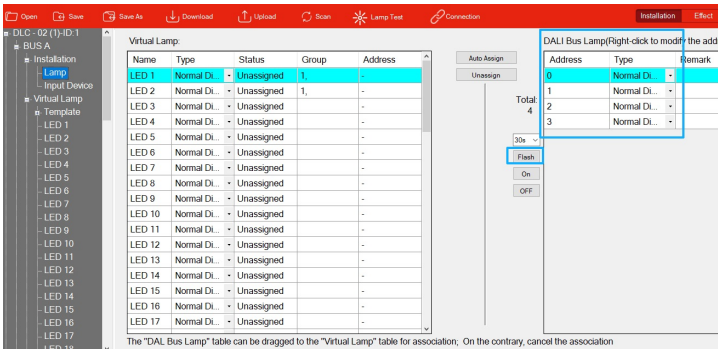

According to the actual positions of the lamps, use the mouse to select the DALI lamps on the right area, and drag them to the corresponding positions of the Virtual Lamp on the left area to complete the pairing.

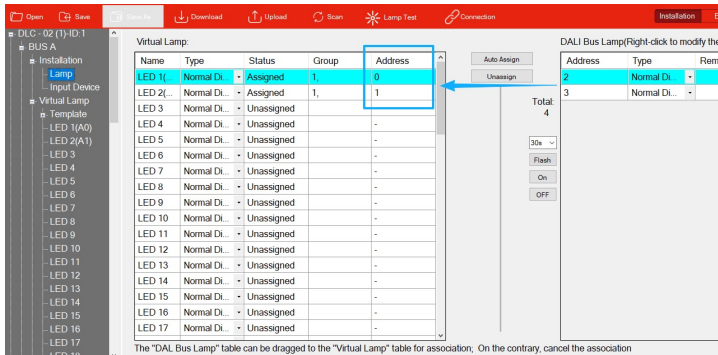

※Pairing Virtual Input Devices with Actual Input Devices

After completing device scanning, click "Bus A - Installation - Input Device". There is 1 input device on DALI Bus A. Select the device, and 2 instances of the device will be displayed in the lower-right corner.

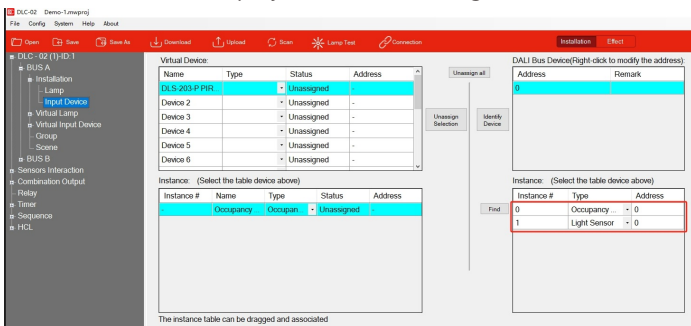

Select "Occupancy Sensor" on the right with the mouse, move it to the virtual instance position on the left, and complete the occupancy sensor pairing.

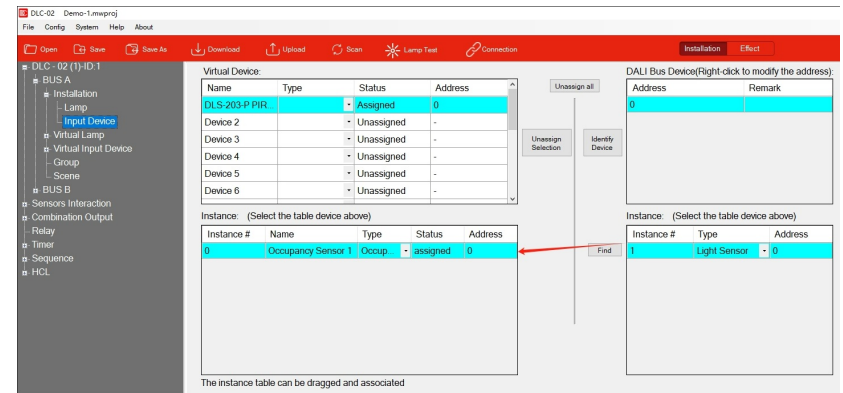

Step 5: Finally, click "Download - Device Parameter and Effects" to download all device parameters and effect configurations to the lamps, input devices, and the DLC-02 controller.

After downloading, the DLS-203-P sensor can turn on or off the pantry lights by detecting the movement of the person.

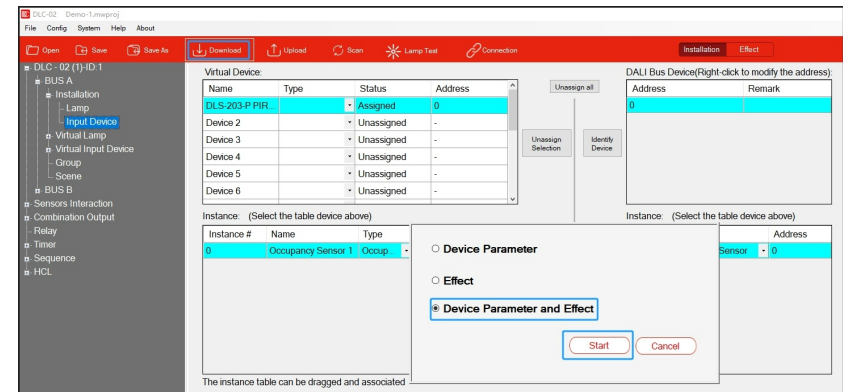

7. Protection Function

7.1 Output overload

When the load power exceeds the rated power of the product, the output voltage will show a continuous hiccup mode. After the overload abnormal condition is relieved, normal output can be automatically recovered.

7.2 Output short circuit

BLANK type : When a short circuit occurs at the output, the output voltage will be turned off. After the short circuit abnormal condition is relieved, it is necessary to restart to recover normal output.

DA2/DA2Q type : When a short circuit occurs at the output, the output voltage will show a continuous hiccup mode. After the short circuit abnormal condition is relieved, normal output can be automatically recovered.

7.3 Output over voltage

When the output voltage exceeds the over voltage protection point of the power supply, the output voltage will be turned off. After the over voltage abnormal condition is relieved, it is necessary to restart to recover normal output.

7.4 Over temperature

When the internal temperature of the power supply is too high, the output voltage will be turned off. After the temperature returns to normal, it is necessary to restart to recover normal output.

8. Warranty

This product provides five years warranty under normal usage. Do not replace parts or any form of modification to the product in order to keep the warranty effectively.

※MEAN WELL possesses the right to adjust the content of this manual.

Please refer to the latest version of our manual on our website.

<https://www.meanwell.com>



9. Environmental Declaration Information

https://www.meanwell.com//Upload/PDF/RoHS_PFOS.pdf

https://www.meanwell.com//Upload/PDF/REACH_SVHC.pdf

https://www.meanwell.com//Upload/PDF/Declaration_RoHS-E.pdf

明緯企業股份有限公司
MEAN WELL ENTERPRISES CO., LTD.

248 新北市五股區五權三路28號
No.28, Wuquan 3rd Rd., Wugu Dist., New Taipei City 248, Taiwan
Tel:886-2-2299-6100 Fax:886-2-2299-6200
<http://www.meanwell.com> E-mail:info@meanwell.com