

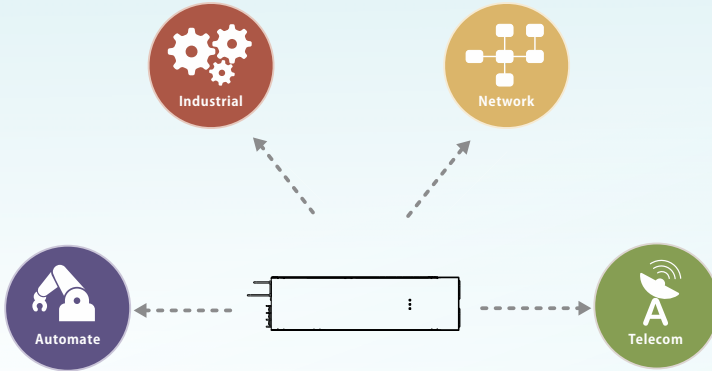

MSP-1600 Series

User's Manual



1600W AC/DC High Reliable Multi-Industries Enclosed Type Power Supply

- Output voltage 15 ~115% programmable
- Extremely low leakage current <500 μ A, 2 x MOPP

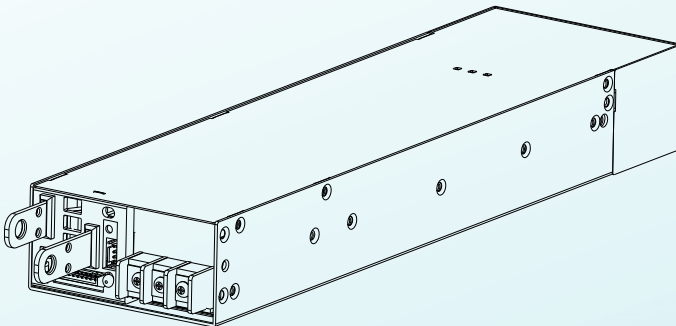

The MSP-1600 series is a 1600W AC/DC power supply with PFC function, designed for high reliability and suitable for multiple industries. Key features include: compact size (310*85*41mm) for better space utilization in system installations, ultra-wide input range of 85~264Vac for global compatibility, up to 92% efficiency, programmable output voltage(15~115%), built-in CAN bus communication interface, wide operating temperature range from -40 to +85°C(+50°C at full load), compliance with OVCIII, built-in Remote Control /Remote Sense/DC OK signal/auxiliary power, internal PCB coating, complete protections, certifications for multiple safety standards including 60601-1, 61558-1, 60335-1, 62477-1, and 61010-1, as well as 2 X MOPP compliance and extremely low leakage current (<500μA). It is suitable for BF-rated medical equipment and comes with a 5-years warranty, making it a highly cost-effective solution for industrial power supply needs.

Contents

1.Safety Guidelines	1	5.5 Auxiliary Output	19
2.Introduction	2	5.6 Inrush Current Limiting	19
2.1 Model Encoding	2	5.7 Power Factor Correction	19
2.2 Features	3	5.8 Fan Speed Control	19
2.3 Specification	4	5.9 Factory Resetting	20
2.4 Static Characteristics	6	6.Communication Protocol	21
2.5 Derating curve	6	6.1 CAN bus Protocol	21
2.6 Mechanical specification	7	6.1.1 Message ID definition	22
3.Installation & Wiring	9	6.1.2 CAN bus Command list	23
3.1 Precautions	9	6.1.3 Communication	31
3.2 Installation Procedures	9	Examples	
3.3 Cable Size Selection	10	6.2 Value Range and Tolerance	33
4.User Interface	11	7.Protections and Trouble	36
4.1 Panel Description	11	Shooting	
4.2 LED Indicator	12	7.1 Protections	36
4.3 Pin Assignment (CN1)	13	7.1.1 Over Load Protection	36
4.4 Pin Assignment (CN2)	14	7.1.2 Over Voltage Protection	36
4.5 Communication Address / ID	15	7.1.3 Over Temperature	36
Assignment		Protection	
5.Explanation of Operation	16	7.1.4 Fan Fail Protection	36
5.1 Output Voltage Adjustment	16	7.1.5 Short Circuit Protection	37
5.1.1 SVR	16	7.1.6 AC Input Under-	37
5.1.2 PV	16	Voltage Protection	
5.1.3 Communication	17	7.2 Trouble Shooting	37
5.2 Remote Control	17	8.Warranty	39
5.3 Voltage Drop Compensation	18	9.Environmental Declaration	40
(Remote Sense/Local Sense)		Information	
5.3.1 Remote Sense	18		
5.3.2 Local Sense	18		
5.4 Output Voltage Signal	18		
(DC-OK)			

1.Safety Guidelines

- Risk of electrical shock and energy hazard. All failures must be examined by a qualified technician. Do not remove the power supply case by yourself.
- Do not install the power supply in locations with high moisture, high ambient temperature or direct sunlight.
- AC input range: 85-264Vac, 47-63 Hz. Do not connect to AC power outside this range.
- Fans and ventilation holes must be kept free from obstructions. Maintain at least 15 cm clearance from adjacent heat source.
- Do not stack any object on the unit.
- The safety protection level of this power supply is Class I. The unit's frame ground (⏏) must be properly connected to PE (Protective Earth).

2.Introduction

2.1 Model Encoding

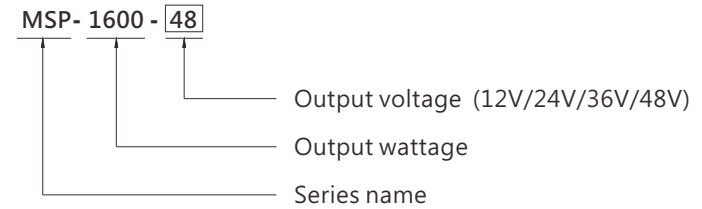

2.2 Features

- 85~264Vac input with PFC
- Global certificates in multi-fields(Medical 60601-1, Household 60335-1, Industrial 61558-1/-2-16/61010-1, Energy converter 62477-1)
- High efficiency up to 92%
- Output voltage 15 ~115% programmable
- Built-in CAN bus protocol
- -40~+85°C wide range operation temperature
- Extremely low leakage current <500μA, 2 x MOPP, suitable for BF medical applications
- Protections: Short circuit / Overload / Over voltage / Over temperature
- Built-in Remote ON/OFF control / Remote Sense / DC OK signal / OTP alarm signal /12Vaux power
- Over voltage category III (OVC III)
- Operating altitude up to 5000 meters
- Built-in intelligent fan speed control, low noise <39dB
- Conformal coating
- 5 years warranty

2.3 Specification

SPECIFICATION	MSP-1600-12	MSP-1600-24	MSP-1600-36	MSP-1600-48
OUTPUT				
DC VOLTAGE	12V	24V	36V	48V
RATED CURRENT	125A	67A	44.5A	33.5A
CURRENT RANGE	0 ~ 125A	0 ~ 67A	0 ~ 44.5A	0 ~ 33.5A
RATED POWER	1500W	1608W	1602W	1608W
RIPPLE & NOISE (max.)	Note.2 150mVp-p	200mVp-p	250mVp-p	300mVp-p
VOLTAGE ADJ. RANGE	11.5 ~ 14V	23.5 ~ 28V	35.5 ~ 42V	47.5 ~ 56V
VOLTAGE TOLERANCE	Note.3 ±1.0%	±1.0%	±1.0%	±1.0%
LINE REGULATION	±0.5%	±0.5%	±0.5%	±0.5%
LOAD REGULATION	±0.5%	±0.5%	±0.5%	±0.5%
SETUP, RISE TIME	1500ms, 60ms/230Vac at full load			
HOLD UP TIME (Typ.)	16ms / 230Vac at 70% load		10ms / 230Vac at full load	
INPUT				
VOLTAGE RANGE	Note.4 85 ~ 264Vac	250 ~ 400Vdc		
FREQUENCY RANGE	47 ~ 63Hz			
POWER FACTOR (Typ.)	0.97/230Vac at full load			
EFFICIENCY (Typ.)	88.5%	90.5%	91%	92%
AC CURRENT (Typ.)	Note.4 14A/115Vac	8A/230Vac	15A/115Vac	8.5A/230Vac
INRUSH CURRENT (Typ.)	COLD START 60A/230Vac			
LEAKAGE CURRENT	Earth leakage current <500μA(rms)/264Vac ; Touch current<100μA(rms)/264Vac			
PROTECTION				
OVERLOAD	105 ~ 115% rated output power Protection type : Constant current limiting, unit will shut down o/p voltage after 5 sec. After O/P voltage falls, re-power on to recover			
OVER VOLTAGE	15.75 ~ 18.75V	31.5 ~ 37.5V	47.2 ~ 56.3V	56 ~ 60V
OVER TEMPERATURE	Shut down o/p voltage, recovers automatically after temperature goes down			
FUNCTION				
OUTPUT VOLTAGE PROGRAMMABLE(PV)	Adjustment of output voltage is allowable to 15 ~ 115% of nominal output voltage Please refer to the Function Manual.			
REMOTE CONTROL	By electrical signal or dry contact Power ON:short Power OFF:open. Please refer to the Function Manual			
REMOTE SENSE	Compensate voltage drop on the load wiring up to 0.5Vdc. Please refer to the Function Manual			
AUXILIARY POWER	12Vaux @ 0.8A, tolerance: 10.6~13.2V; Ripple: 450mV			
DC OK SIGNAL	Contact rating(max.):5Vdc/10mA resistive load			
CANBus(Built-in)	Communication provides functions such as control, setting and monitoring			
FAN SPEED CONTROL(Typ.)	Note.7 10% load with Ta=25°C 39dB	39dB	39dB	39dB
	70% load with Ta=25°C 43dB	39dB	39dB	39dB
ENVIRONMENT				
WORKING TEMP.	-40 ~ +85°C (Refer to "Derating Curve")			
WORKING HUMIDITY	20 ~ 90% RH non-condensing			
STORAGE TEMP., HUMIDITY	-40 ~ +85°C, 10 ~ 95% RH non-condensing			
TEMP. COEFFICIENT	±0.03%/°C (0 ~ 50°C)			
VIBRATION	10 ~ 500Hz, 2G 10min./1 cycle, 60min. each along X, Y, Z axes			

SAFETY & EMC (Note.8)			
SAFETY STANDARDS	CB IEC60335-1, IEC61558-1/2-16, IEC61010-1/2-201, IEC60601-1(3.2 version); IEC62477-1, IEC62368-1 DEKRA BS EN/EN60601-1, BS EN/EN60335-1, BS EN/EN61558-1/2-16, BS EN/EN61010-1/2-201, BS EN/EN62477-1 UL ANSI/AAMI ES60601-1(3.2 Version), UL61010-1/2-201 COC GB4943.1 BSMI CNS15598-1 EAC TP TC 004 SEMI F47 approved KC/BIS KC 62368-1 and BIS IS 13252(Part 1) certified, no stock by request, contact sales for inquires		
ISOLATION LEVEL	Primary-Secondary: 2xMOPP, Primary-Earth: 1xMOPP, Secondary-Earth: 1xMOPP		
OVER VOLTAGE CATEGORY	IEC/EN 61558-1/2-16 (OVC III, altitude up to 2000M) IEC 62368-1 (OVC II, altitude up to 5000M) IEC/EN 60335-1 (OVC II, altitude up to 5000M) IEC/EN/ANSI/AAMI ES60601-1 (OVC II, altitude up to 4000M) IEC/EN/UL 61010-1/2-201 (OVC II, altitude up to 5000M) IEC/EN 62477-1 (OVC II, altitude up to 5000M)		
SAFETY EXTRA-LOW VOLTAGE(SELV)	IEC/EN 61558-2-16 (SELV, 12 ~ 48V) IEC/EN 60335-1 (SELV, 12 ~ 36V) IEC 62368-1 (SELV/ES1, 12 ~ 48V)		
WITHSTAND VOLTAGE	I/P-O/P: 4.2KVac I/P-FG: 2.1KVac O/P-FG: 1.5KVac		
ISOLATION RESISTANCE	I/P-O/P, I/P-FG, O/P-FG: 100M Ohms / 500Vdc / 25°C / 70% RH		
EMC EMISSION	Parameter	Standard	
	Conducted	BS EN/EN55032(CISPR32), CNS 15936, GB/T 9254.1, KS C 8832	Class B
		BS EN/EN55014-1(CISPR14-1)	-----
		BS EN/EN55011(CISPR11)	Class B
	Radiated	BS EN/EN55032(CISPR32), CNS 15936, GB/T 9254.1, KS C 8832	Class B
		BS EN/EN55014-1(CISPR14-1)	-----
		BS EN/EN55011(CISPR11)	Class B
Harmonic Current	BS EN/EN61000-3-2(IEC61000-3-2)		Class A
Voltage Flicker	BS EN/EN61000-3-3(IEC61000-3-3)		-----
EMC IMMUNITY	BS EN/EN55035(CISPR35), BS EN/EN61000-6-2(IEC61000-6-2), BS EN/EN60601-1-2(IEC60601-1-2), BS EN/EN55014-2(CISPR14-2), KS C 9835, SEMI F47 tested at 200Vac		
	Parameter	Standard	Test Level / Note
	ESD	BS EN/EN61000-4-2	Level 4, 15KV air ; Level 4, 8KV contact
	Radiated	BS EN/EN61000-4-3	Level 3, 10V/m(80MHz-2.7GHz) Table 9, 9~28V/m(385MHz-5.78GHz)
	EFT / Burst	BS EN/EN61000-4-4	Level 3, 2KV
	Surge	BS EN/EN61000-4-5	Level 4, 2KV/Line-Line 4KV/Line-Earth
	Conducted	BS EN/EN61000-4-6	Level 3, 10V
Magnetic Field	BS EN/EN61000-4-8	Level 4, 30A/m	
Voltage Dips and Interruptions	BS EN/EN61000-4-11	>95% dip 0.5 periods, 30% dip 25 periods, >95% interruptions 250 periods	
OTHERS			
MTBF	653.8K hrs min. Telcordia SR-332 (Bellcore) ; 65.3K hrs min. MIL-HDBK-217F (25°C)		
DIMENSION	310*85*41mm (L*W*H)		
PACKING	1.72Kg/6pcs/11.3Kg/1.28CUFT		
NOTE			
<ol style="list-style-type: none"> All parameters NOT specially mentioned are measured at 230Vac input, rated load and 25°C of ambient temperature. Ripple & noise are measured at 20MHz of bandwidth by using a 12" twisted pair-wire terminated with a 0.1uF & 47uF parallel capacitor. Tolerance : includes set up tolerance, line regulation and load regulation. Derating may be needed under low input voltages. Please check the derating curve for more details. If use PV signal to adjust Vo, under certain operation conditions, ripple noise of Vo might go over rating defined in this specification. Length of set up time is measured at first cold start. Turning ON/OFF the power supply may lead to increase of the set up time. FAN noise test set up according to ISO-7779. The power supply is considered a component which will be installed into a final equipment. All the EMC tests are been executed by mounting the unit on a 720mm*360mm metal plate with 1mm of thickness. The final equipment must be re-confirmed that it still meets EMC directives. For guidance on how to perform these EMC tests, please refer to "EMI testing of component power supplies." (as available on https://www.meanwell.com/Upload/PDF/EMI_statement_en.pdf) The ambient temperature derating of 3.5°C/1000m with fanless models and of 5°C/1000m with fan models for operating altitude higher than 2000m(6500ft). The Regulatory Compliance Mark (RCM) is applied on a voluntary basis. The equipment meets the relevant IEC or AS/NZS standards, or AS/NZS 3820 where applicable. The use of the RCM mark complies with AS/NZS 4417.1. Some factory or model may not have the BIS logo, please contact your MEAN WELL sales for more information. 			
※ Product Liability Disclaimer : For detailed information, please refer to https://www.meanwell.com/serviceDisclaimer.aspx			

2.4 Static Characteristics

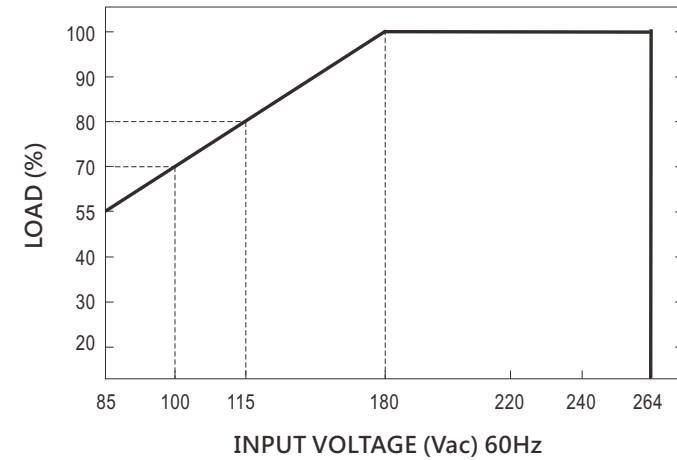

2.5 Derating Curve

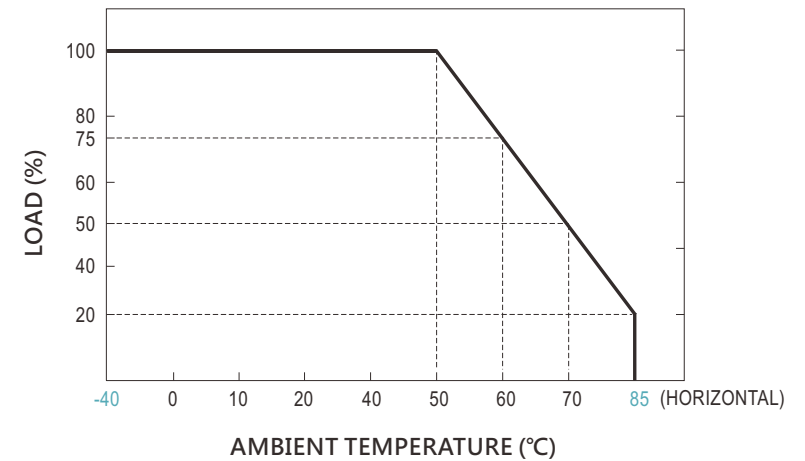

2.6 Mechanical specification

(Unit: mm, tolerance $\pm 0.5\text{mm}$)

Case No.296C

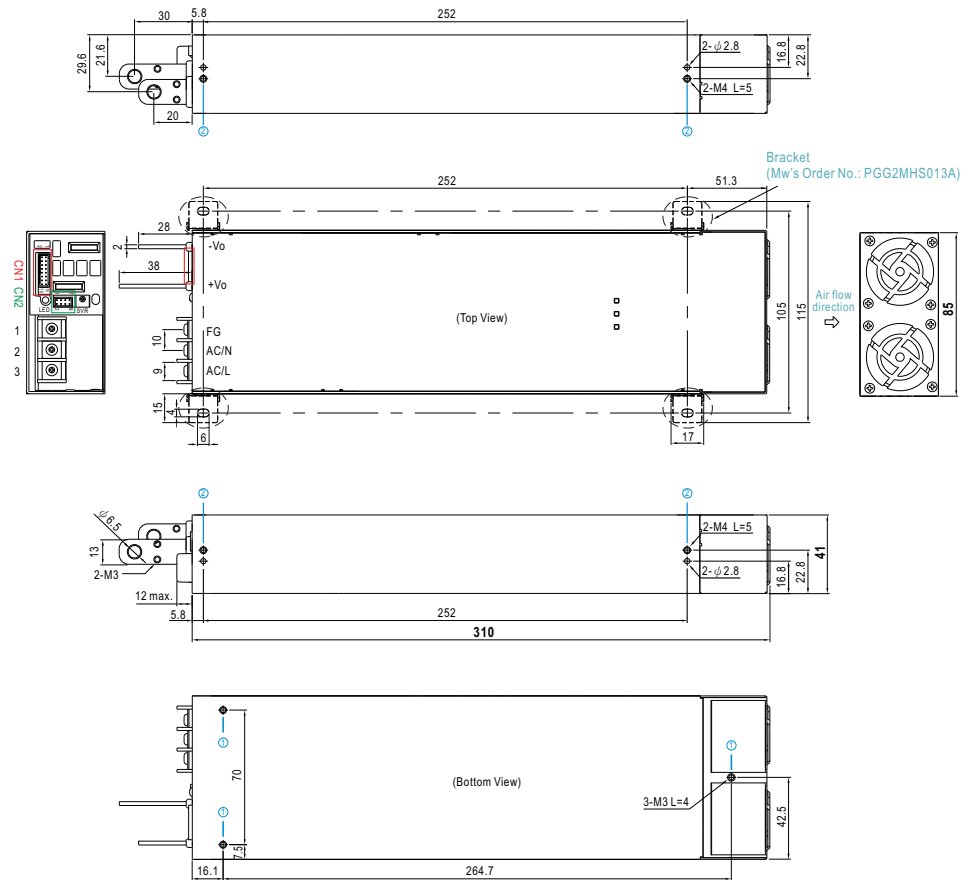

※ Mounting Instruction

Hole No.	Recommended Screw Size	MAX. Penetration Depth L	Recommended mounting torque
①	M3	4mm	6~8Kgf-cm
②	M4	5mm	7~10Kgf-cm

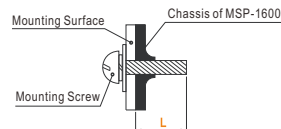

※ Terminal Pin No.

Pin No.	Assignment	Terminal	Screw Thread	Max. mounting torque
1	FG ㄱ	1 2 3	M3.5	8Kgf-cm
2	AC/N			
3	AC/L			

Accessory List

No.	Item	Quantity
1	Control function interface(CN1) mating wire along with MSP-1600 (standard accessory)	1pcs/per model
2	Bracket Mw's Order No.: PGG2MHS013A (By request accessory, should ordered separately)	4pcs/per model (Please refer to Installation Diagram)
3	Terminal cover MW' S Order NO.: PEE4TBC-03-DG (By request accessory, should ordered separately)	1pcs/per model

Installation Diagram

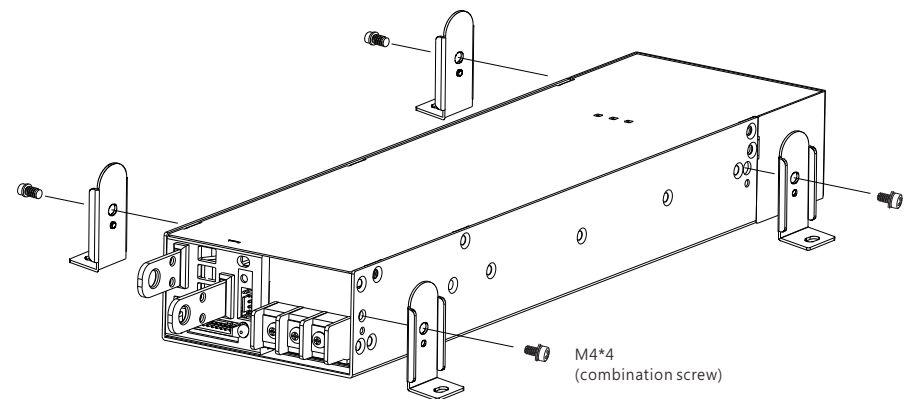

3.Installation & Wiring

3.1 Precautions

- Ensure the system chassis has sufficient strength to support the unit.
- To ensure the lifespan of the unit, do not operate the unit in high-dust or high-moisture environments.
- The MSP-1600 series is designed with built-in DC fans. Ensure the ventilation is not blocked and maintain at least 15 cm clearance around the ventilation openings.

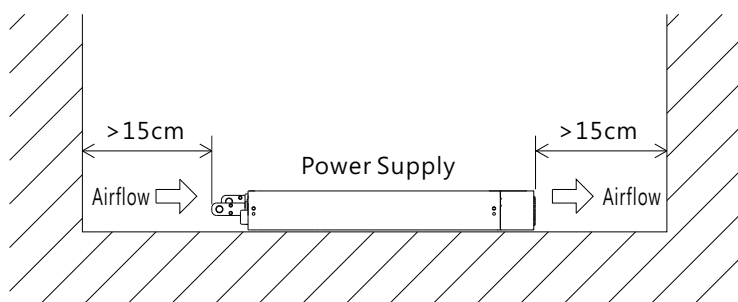

Figure 3-1 Mounting Diagram

3.2 Installation Procedures

- ① Select cables with appropriate wire gauge for the MSP-1600 series input and output connections. Refer to 3.3 for cable size selection.
- ② Ensure the AC input and DC output terminals of the MSP-1600 series are correctly connected. Do not reverse the DC output polarity or cause a short circuit.

3.3 Cable Size Selection

Wire connection should be as short as possible, preferably less than 1 meter. Ensure wires are selected according to applicable safety requirements and current rating. A smaller cross-section will reduce efficiency, limit the output power, and may cause the wires to overheat, creating a potential safety hazard.

- ① AC input side: It is recommended to use 14 AWG wires.
- ② DC output side: Refer to Table 3-1 for wire recommendations.

Table 3-1 wire recommendations

AWG	Cross-section on Area (mm ²)	Maximum DC current (A)
8	6	40A
6	10	60A
4	16	80A
2	25	100A
1	35	125A
0	50	160A
000	75	190A
0000	95	230A

4. User Interface



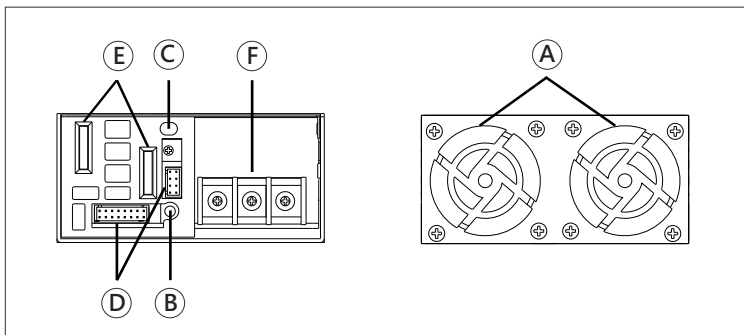

4.1 Panel Description

- (A) Ventilation holes for fans:**
The power supply requires adequate ventilation to operate properly. Ensure sufficient airflow to maintain the optimal performance and extend service life.
- (B) LED indicator:**
The LED indicator shows the operating status. Refer to Section 4.2 for details.
- (C) SVR:**
This is used to adjust the DC output voltage.
- (D) Connection ports (CN1 and CN2):**
The connection ports are used to switch operating modes and monitor the power supply status. Refer to Section 4.3 and Section 4.4 for pin assignment.
- (E) DC output terminals:**
Refer to Section 3.3 for wiring instructions. Use M6 screws for connection with a recommended torque of 33.1 kgf-cm. Screws and other accessories are included in the accessory bag.
- (F) AC input terminals:**
It is recommended to use 14 AWG wires. Use M3.5 screws for connection with a recommended torque of 8 kgf-cm.



4.2 LED Indicator

The power supply monitors its operating status and displays the corresponding status through different LED colors and blink patterns, as shown in the table below. Refer to Chapter 7 for explanations of the fault causes and troubleshooting methods.

LED Status	Description
● Green	Normal operation
● Red	Remote OFF
☀ Red: Continuous Blink	High ambient temperature alarm (Note 1)
☀ Red: 1 Blink/Pause 	Overload Protection (OLP)
☀ Red: 2 Blink/Pause 	Over Voltage Protection (OVP)
☀ Red: 3 Blink/Pause 	Over Temperature Protection (OTP)
☀ Red: 4 Blink/Pause 	Fan Fail
☀ Red: 5 Blink/Pause 	Others (Note 2)

Note 1. The high ambient temperature alarm is for notification purposes only and will not shut down the output.

Note 2. AC under-voltage protection, short-circuit protection and EEPROM access error... etc. are included in this error code.

4.3 Pin Assignment (CN1)

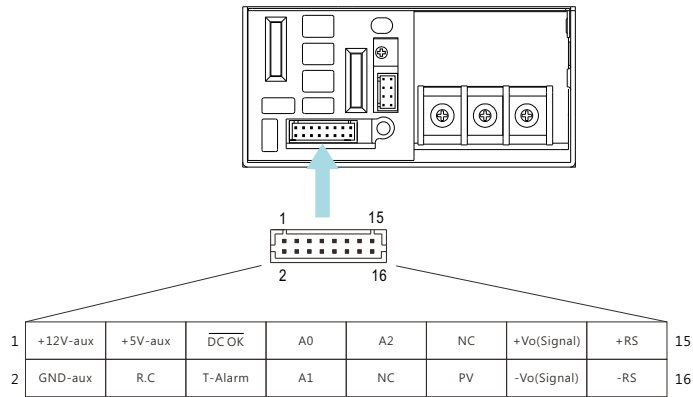

Connect Pin No. Assignment: HRS DF11-16DP-2DS or equivalent

Pin No.	Function	Description
1	+12V-aux	Auxiliary voltage output, 10.6~13.2Vdc, referenced to GND-aux (pin2). The maximum load current is 0.8A. This output has the built-in "Oring diodes" and is not controlled by "Remote ON-OFF".
2	GND-aux	Auxiliary voltage output GND. The signal return is isolated from the output terminals (+Vo & -Vo).
3	+5V-aux	This pin is use for remote ON-OFF usage only.
4	R.C	The unit can turn the output ON/OFF by electrical signal or dry contact between Remote ON/OFF and +5V-aux. (Note.2) Short (4.5 ~ 5.5Vdc) : Power ON ; Open (-0.5 ~ 0.5Vdc) : Power OFF ; The maximum input voltage is 5.5Vdc.
5	DC-OK	High (3.5 ~ 5.5Vdc) : When the $V_{out} \leq 77\% \pm 5\%$. Low (-0.5 ~ 0.5Vdc) : When $V_{out} \geq 80\% \pm 5\%$. The maximum sourcing current is 10mA and only for output. (Note.2)
6	T-Alarm	High (3.5 ~ 5.5Vdc) : When the internal temperature exceeds the limit of temperature alarm, or when Fan fails. Low (-0.5 ~ 0.5Vdc) : When the internal temperature is normal, and when Fan works normally. The maximum sourcing current is 10mA and only for output(Note.2)
7,8,9	A0,A1,A2	Interface addresses lines. Refer to Section 4.5 for details. (Note.1)
10,11	NC	Retain for future use.
12	PV	Connection for output voltage programming. (Note.1)
13	+Vo(Signal)	Positive output voltage signal. It is for local sense; it cannot be connected directly to the load.
14	-Vo(Signal)	Negative output voltage signal. It is for local sense and certain function reference; it cannot be connected directly to the load.
15	+RS	Positive sensing for remote sense.
16	-RS	Negative sensing for remote sense.

Note1: Non-isolated signal, referenced to [-Vo(signal)].

Note2: Isolated signal, referenced to [GND-aux].

4.4 Pin Assignment (CN2)

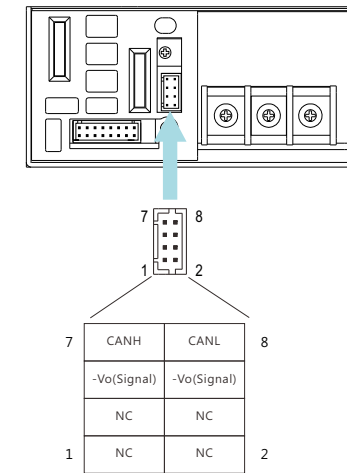

Connect Pin No. Assignment: HRS DF11-8DP-2DS or equivalent

Pin No.	Function	Description
1,2,3,4	NC	For standard model: Retain for future use.
5,6	-Vo(Signal)	Negative output voltage signal. It is for local sense and certain function reference; it cannot be connected directly to the load.
7	CANH	For CAN bus model: Data line used in CAN bus interface. (Note 1)
8	CANL	For CAN bus model: Data line used in CAN bus interface. (Note 1)

Note 1: Isolated signal, referenced to [GND-aux].

4.5 Communication Address / ID Assignment

Each MSP-1600 unit must have a unique device address for bus communication. Configuration method is as follows: Connecting any of CN1 pins A0, A1, or A2 to pin 14 (-Vo(Signal)) sets that pin to logic 0. Leaving the pin unconnected sets it to logic 1. As shown in the table below, up to 8 address combinations (00-07) are available.

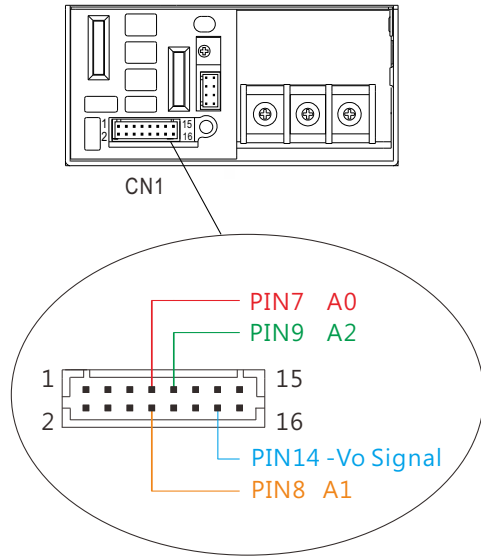

Module No.	Device address		
	A2	A1	A0
	Control Pin No		
00	9	8	7
01	0	0	1
02	0	1	0
03	0	1	1
04	1	0	0
05	1	0	1
06	1	1	0
07	1	1	1

5.Explanation of Operation

5.1 Output Voltage Adjustment

Output voltage can be adjusted via SVR, PV and communication interface. The priority order is: communication > PV > SVR. When a higher priority method is active, lower priority methods are overridden.

5.1.1 SVR

Output voltage can be trimmed by the SVR, as shown in the figure below. The adjustment range is specified in the table below.

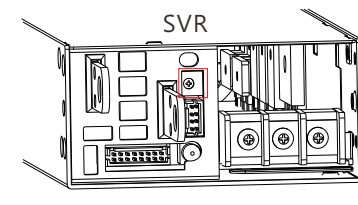

Model	Adjustment Range
12V	11.5~14 V
24V	23.5~28 V
36V	35.5~42 V
48V	47.5~56 V

5.1.2 PV (Output Voltage Programming)

A. Connect an external DC voltage to PV and -Vo(Signal), as shown in the illustration below.

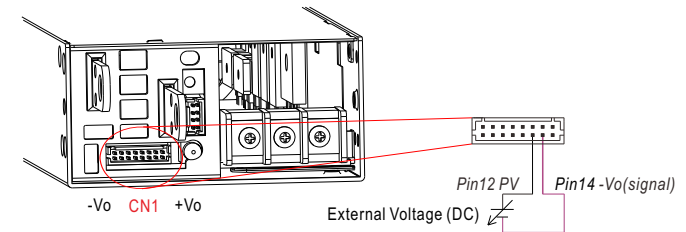

B. Relationship between output voltage and external DC voltage is shown in the curve below.

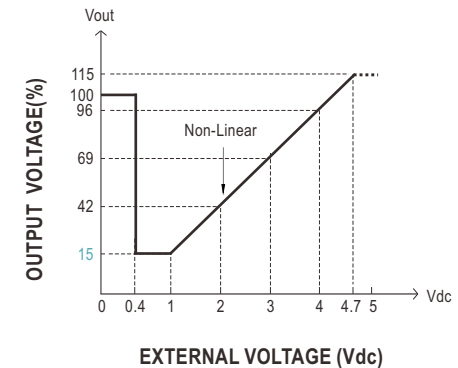

C. When the output voltage is set above the rated voltage, a corresponding decrease in output current is required. The output power should not exceed the rated value under any circumstance.

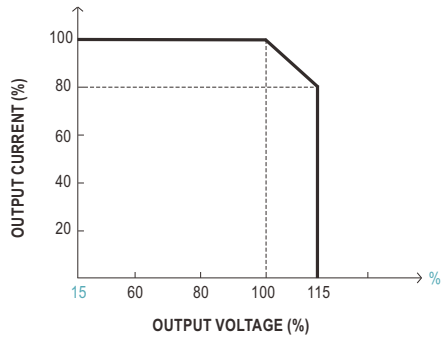

5.1.3 Communication

Output voltage can be adjusted through CAN bus interface. Refer to Chapter 6 for details.

5.2 Remote Control

The power supply can be turned ON/OFF individually or along with other units by using the "Remote Control" function.

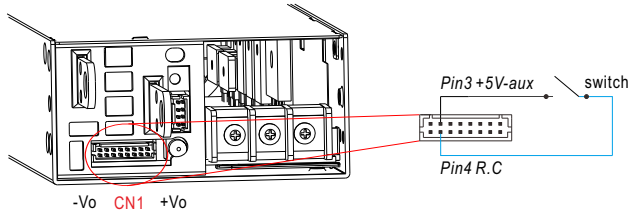

PSU Vo Status	Between +5V-aux(Pin 3) and R.C(Pin 4)
Power ON	Switch Short
Power OFF	Switch Open

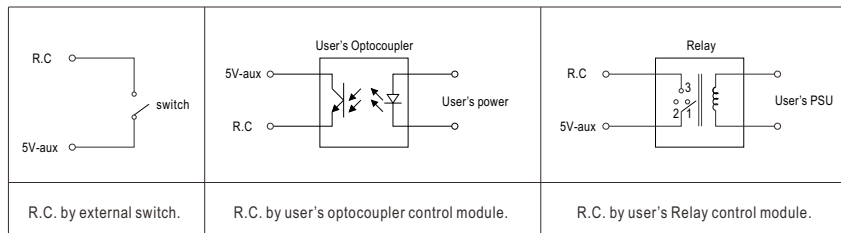

5.3 Voltage Drop Compensation (Remote Sense/Local Sense)

5.3.1 Remote Sense

The Remote Sense compensates voltage drop on the load wiring up to 0.5Vdc

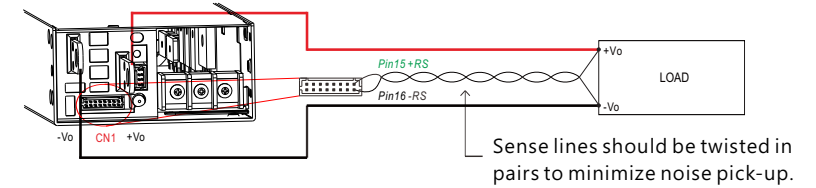

◎ The +RS signal should be connected to the positive terminal of the load whereas -RS signal to the negative terminal.

5.3.2 Local Sense

The +RS,-RS have to be connected to the +Vo(signal), -Vo(signal), respectively, as shown below, in order to get the correct output voltage if Remote Sense is not used.

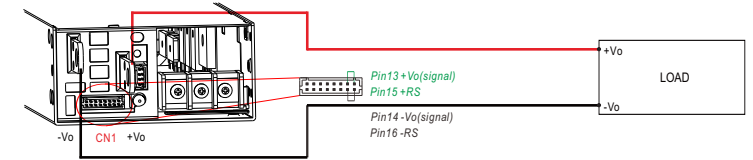

5.4 Output Voltage Signal (DC-OK)

Built-in DC output voltage detection circuit provides TTL signal output based on voltage status. Signal is isolated from output, max current: 10mA.

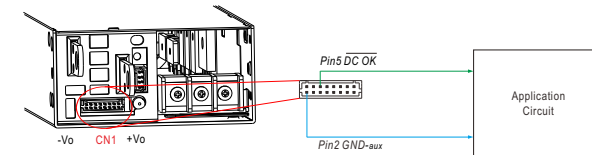

DC-OK to GND-aux	DC Output Status
3.5 ~ 5.5V (High)	Abnormal ($V_o \leq 77\% \pm 5\%$)
-0.5 ~ 0.5V (Low)	Normal ($V_o \geq 80\% \pm 5\%$)

5.5 Auxiliary Output

Built-in 12VDC auxiliary output: 0.8A max.

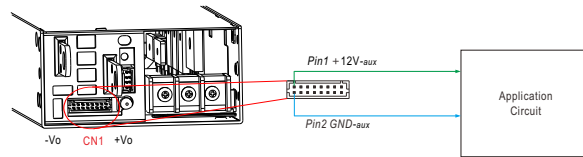

5.6 Inrush Current Limiting

Since the inrush current limit circuit mainly consists of a thermistor and a relay, inrush current will be much higher than the specified value if input thermistor is not allowed sufficient time to cool down. After turning OFF the unit, a 10 second cool down period is recommended before turning ON again.

5.7 Power Factor Correction (PFC)

Built-in active power factor correction (PFC) function, power factor (PF) will be greater than 0.97 when the input voltage is 230Vac and operated at full load condition. PF will be less than 0.97 if the output is not at full load or the input voltage is higher than 230Vac.

5.8 Fan Speed Control

Built-in fan speed control circuit, fan speed changes automatically depending on internal temperature.

5.9 Factory Resetting

- Users can follow the steps below to restore factory settings for commands: 0x0000, 0x0020, 0x0030, and 0x00C2. Refer section 6.1.2 for CAN bus Command list.
 - Turn off the AC power and short each Address pin (A0~A2) to -Vo(Signal).
 - Turn on the AC power in REMOTE OFF mode (no output at this step).
 - Within 15 seconds of turning on AC power, change the Address pins (A0~A2) from "shorted" to "open," then back to "shorted."
 - Green LED will blink 3 times if set successfully. Turn off the AC power and wait for the LED to turn off. Then turn on the AC power again. The unit has now been successfully reset to factory default settings.
 - If the EEPROM storage function was DISABLE (high byte bit 2 set to "logic 1" in SYSTEM_CONFIG(0x00C2)), please perform step ① - ④ again to fully restore the parameters back to factory settings.

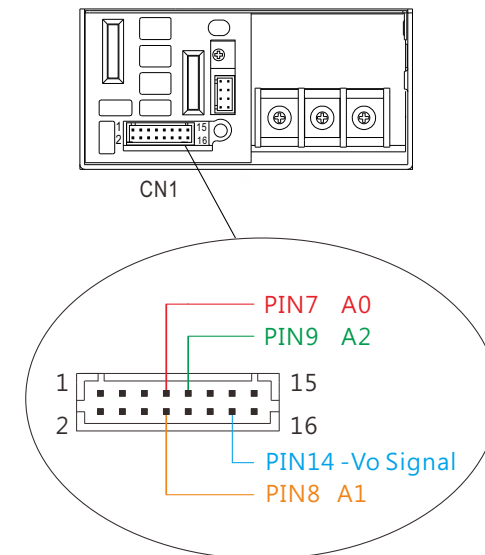

6.Communication Protocol

- There are two means to control the power supply, analog signals and digital communication. Analog is the default setting for the supply, signals including PV and SVR can be used immediately once receiving the supply.

The digital communication of CAN bus is initially uncontrollable but readable. To activate the digital communication, please set CAN_CTRL of SYSTEM_CONFIG (0x00C2) at "1". Once the digital communication dominates the supply, the analog signals become invalid. Refer to Section 6.1.2 for CAN bus Command list.

Note:

- At default setting of analog, the following commands are invalid but can be written while other commands are effective: OPERATION (0x0000), VOUT_SET (0x0020), and IOUT_SET (0x0030).
- All written parameters of commands: 0x0000, 0x0020 and 0x0030 are saved into EEPROM and take effect after the digital is activated.

6.1 CAN bus Protocol

Physical layer specification

This protocol follows CAN ISO-11898 with Baud rate of 250Kbps.

Data Frame

This protocol uses Extended CAN 29-bit identifier frame format or CAN2.0B.

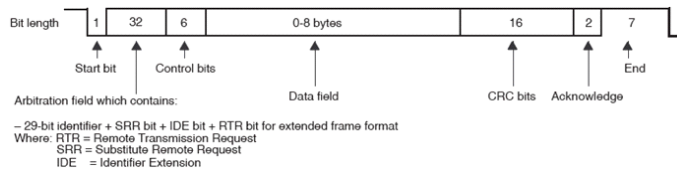

Communication Timing

- Min. request period (Controller to MSP-1600): 50mSec ◦
- Max. response time (MSP-1600 to Controller): 12.5mSec ◦
- Min. packet margin time (Controller to MSP-1600): 12.5mSec ◦

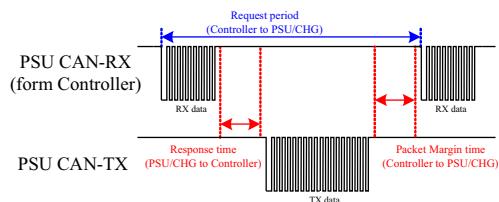

- Data Field Format (Refer to Section 6.1.3 for communication examples)

Controller to MSP-1600

Write:

Data filed bytes

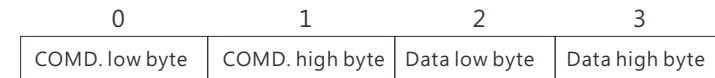

Read:

Data filed bytes



MSP-1600 to Controller

Response:

Data filed bytes

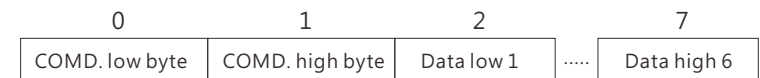

NOTE: MSP-1600 will not send data back when writing parameters, such as VOUT_SET

6.1.1 Message ID definition

Message ID	Description
0x000C00XX	MSP-1600 to Controller Message ID
0x000C01XX	Controller to MSP-1600 Message ID
0x000C01FF	Controller broadcasts to MSP-1600

Note: XX means the address of MSP-1600. Refer to Section 4.5 for Communication Address / ID Assignment.

6.1.2 CAN bus Command list

Command Code	Command Name	Transaction Type	# of data Bytes	Description
0x0000	OPERATION	R/W	1	ON/OFF control ON: 01h / OFF: 00h
0x0020	VOUT_SET*	R/W	2	Output voltage set (Factor=0.1)
0x0030	IOUT_SET*	R/W	2	Output current set (Factor=0.1)
0x0040	FAULT_STATUS	R	2	Abnormal status
0x0050	READ_VIN	R	2	Input voltage read value (Factor=0.1)
0x0060	READ_VOUT	R	2	Output voltage read value (Factor=0.1)
0x0061	READ_IOUT	R	2	Output current read value (Factor=0.1)
0x0062	READ_TEMPERATURE_1	R	2	Internal ambient temperature (Factor=0.1)
0x0070	READ_FAN_SPEED_1	R	2	Fan speed 1 reading value (Factor=1)
0x0071	READ_FAN_SPEED_2	R	2	Fan speed 2 reading value (Factor=1)
0x0080	MFR_ID_B0B5	R	6	Manufacturer's name (first 6 digits)
0x0081	MFR_ID_B6B11	R	6	Manufacturer's name (last 6 digits)
0x0082	MFR_MODEL_B0B5	R	6	Manufacturer's model name (first 6 digits)
0x0083	MFR_MODEL_B6B11	R	6	Manufacturer's model name (last 6 digits)
0x0084	MFR_REVISION_B0B5	R	6	Firmware version
0x0085	MFR_LOCATION_B0B2	R/W	3	Manufacturer's factory location
0x0086	MFR_DATE_B0B5	R/W	6	Manufacture date
0x0087	MFR_SERIAL_B0B5	R/W	6	Product serial number (first 6 digits)
0x0088	MFR_SERIAL_B6B11	R/W	6	Product serial number (last 6 digits)
0x00C0	SCALING_FACTOR	R	6	Scaling ratio
0x00C1	SYSTEM_STATUS	R	2	System status
0x00C2	SYSTEM_CONFIG	R/W	2	System configuration
0x0910	CLEAR_LOG	W	2	Clear Event Log
0x0921	EVENT_0	R	2	Latest Event Log
0x0922	EVENT_1	R	2	Previous Event Log
0x0923	EVENT_2	R	2	2 nd Previous Event Log
0x0924	EVENT_3	R	2	3 rd Previous Event Log
0x0925	EVENT_4	R	2	4 th Previous Event Log

Note. Setting command with * at the end support the EEP_OFF and EEP_CONFIG functions.
Refer to SYSTEM_CONFIG (0x00C2) for detailed information on how to enable them.

Data conversion:

The calculation for setting and reading values is defined as:
Actual Value = Communication Read Value × Factor Value,
where the factor value is used for both writing and reading during communication for data conversion. Each command may have a different factor value, which can be found in the command list or retrieved from the SCALING_FACTOR (0x00C0) command.

For Example:

Vo_real (actual DC voltage) = READ_VOUT × Factor.

If the Factory of READ_VOUT of a certain mode is 0.1, the communication reading value is 0x00F0(hexadecimal)→240(decimal), then $VDC_real = 240 \times 0.1 = 24.0V$.

◎FAULT_STATUS(0x0040) :

	Bit7	Bit6	Bit5	Bit4	Bit3	Bit2	Bit1	Bit0
High byte	-	-	-	-	-	-	-	-
Low byte	HI_TEMP	OP_OFF	AC_FAIL	SHORT	OLP	OVP	OTP	FAN_FAIL

Low byte

Bit 0 FAN_FAIL : Fan locked flag

0 = Working normally

1 = Fan locked

Bit 1 OTP : Over temperature protection

0 = Internal temperature normal

1 = Internal temperature abnormal

Bit 2 OVP : DC over voltage protection

0 = DC voltage normal

1 = DC over voltage protected

Bit 3 OLP : DC over current protection

0 = DC current normal

1 = DC over current protected

Bit 4 SHORT : Short circuit protection

0 = Shorted circuit do not exist

1 = Shorted circuit protected

Bit 5 AC_FAIL : AC abnormal flag

0 = AC input range normal

1 = AC input range abnormal

Bit 6 OP_OFF : DC status

0 = DC output turned on

1 = DC output turned off

Bit 7 HI_TEMP : Internal high temperature alarm
 0 = Internal temperature normal
 1 = Internal temperature abnormal

Note: Unsupported settings displays with "0"

©MFR_ID_B0B5 (0x0080) is the first 6 codes of the manufacturer's name (ASCII); MFR_ID_B6B11 (0x0081) is the last 6 codes of the manufacturer's name (ASCII)

EX: Manufacturer's name is MEANWELL MFR_ID_B0B5 is MEANWE ; MFR_ID_B6B11 is LL

MFR_ID_B0B5					
Byte 0	Byte 1	Byte 2	Byte 3	Byte 4	Byte 5
0x4D	0x45	0x41	0x4E	0x57	0x45

MFR_ID_B6B11					
Byte 0	Byte 1	Byte 2	Byte 3	Byte 4	Byte 5
0x4C	0x4C	0x20	0x20	0x20	0x20

©MFR_MODEL_B0B5 (0x0082) is the first 6 codes of the manufacturer's model name (ASCII); MFR_MODEL_B6B11 (0x0083) is the last 6 codes of the manufacturer's model name (ASCII)

EX: Model names is MSP-1600-48 → MFR_MODEL_B0B5 is MSP-16 ; MFR_MODEL_B6B11 is 00-48

MFR_MODEL_B0B5					
Byte 0	Byte 1	Byte 2	Byte 3	Byte 4	Byte 5
0x4D	0x53	0x50	0x2D	0x31	0x36

MFR_ID_B6B11					
Byte 6	Byte 7	Byte 8	Byte 9	Byte 10	Byte 11
0x30	0x30	0x2D	0x34	0x38	0x20

©MFR_REVISION_B0B5 (0x0084) is the firmware revision (hexadecimal). A range of 0x00 (R00.0)~0xFE (R25.4) represents the firmware version of an MCU; 0xFF represents no MCU existed.

EX: The supply has two MCUs, the firmware version of the MCU number 1 is version R01.3 (0x0D), the MCU number 2 is version R01.2 (0x0C)

Byte 0	Byte 1	Byte 2	Byte 3	Byte 4	Byte 5
0x0D	0x0C	0xFF	0xFF	0xFF	0xFF

©MFR_DATE_B0B5 (0x0086) is manufacture date (ASCII)

EX: MFR_DATE_B0B5 is 250101, meaning 2025/01/01

Byte 0	Byte 1	Byte 2	Byte 3	Byte 4	Byte 5
0x32	0x35	0x30	0x31	0x30	0x31

©MFR_SERIAL_B0B5 (0x0087) and MFR_SERIAL_B6B11 (0x0088) are defined as manufacture date and manufacture serial number (ASCII)

EX: The 31st unit manufactured on 2025/1/1 MFR_SERIAL_B0B5 is 250101; MFR_SERIAL_B6B11 is 000031

MFR_ID_B0B5					
Byte 0	Byte 1	Byte 2	Byte 3	Byte 4	Byte 5
0x32	0x35	0x30	0x31	0x30	0x31

MFR_ID_B6B11					
Byte 0	Byte 1	Byte 2	Byte 3	Byte 4	Byte 5
0x30	0x30	0x30	0x30	0x33	0x31

©SCALING_FACTOR (0x00C0) :

Bit7~Bit0								
byte4~5	Reserved							
	Bit7	Bit6	Bit5	Bit4	Bit3	Bit2	Bit1	Bit0
byte3	Reserved				Reserved			
	Bit7	Bit6	Bit5	Bit4	Bit3	Bit2	Bit1	Bit0
byte2	Reserved				TEMPERATURE_1 Factor			
	Bit7	Bit6	Bit5	Bit4	Bit3	Bit2	Bit1	Bit0
byte1	FAN_SPEED Factor				VIN Factor			
	Bit7	Bit6	Bit5	Bit4	Bit3	Bit2	Bit1	Bit0
byte0	IOUT Factor				VOUT Factor			

byte0:

Bit 0:3 VOUT Factor : The factor of output voltage
 0x0=Output voltage relevant commands not supported
 0x4=0.001
 0x5=0.01
 0x6=0.1
 0x7=1.0
 0x8=10
 0x9=100

Bit 4:7 IOUT Factor : The Factor of DC current

0x0=Output current relevant commands not supported

0x4=0.001

0x5=0.01

0x6=0.1

0x7=1.0

0x8=10

0x9=100

byte1:

Bit 0:3 VIN Factor : The Factor of AC input voltage

0x0=AC input relevant commands not supported

0x4=0.001

0x5=0.01

0x6=0.1

0x7=1.0

0x8=10

0x9=100

Bit 4:7 FAN_SPEED Factor : The Factor of fan speed

0x0=Fan speed relevant commands not supported

0x4=0.001

0x5=0.01

0x6=0.1

0x7=1.0

0x8=10

0x9=100

byte2:

Bit 0:3 TEMPERATURE_1 Factor : The Factor of internal ambient temperature

0x0=internal ambient temperature relevant commands not supported

0x4=0.001

0x5=0.01

0x6=0.1

0x7=1.0

0x8=10

0x9=100

©SYSTEM_STATUS(0x00C1) :

	Bit7	Bit6	Bit5	Bit4	Bit3	Bit2	Bit1	Bit0
High byte	-	-	-	-	-	-	-	RC
Low byte	-	EEPER	INITIA-LSTATE	-	-	-	DC_OK	-

Low byte:

Bit 1 DC_OK : Secondary DD output voltage status

0 = Secondary DD output voltage status TOO LOW

1 = Secondary DD output voltage status NORMAL

Bit 5 INITIAL_STATE : Device initialized status

0 = NOT in initialization status

1 = In initialization status

Bit 6 EEPER : EEPROM data access error

0 = EEPROM data access normal

1 = EEPROM data access error

Note. When EEPROM data is corrupted, the PSU will shut down and enter protection mode. The PSU will restart only after the issue is resolved and the unit is power cycled.

High Byte:

Bit 0: RC: Remote ON/OFF state

0 = Currently in Remote OFF state

1 = Currently in Remote ON state

Note. Unsupported settings displays with "0"

©SYSTEM_CONFIG(0x00C2) :

	Bit7	Bit6	Bit5	Bit4	Bit3	Bit2	Bit1	Bit0
High byte	-	-	-	-	-	EEP_OFF	EEP_CONFIG	
Low byte	-	-	-	-	-	OPERATION_INIT		CAN_CTRL

Low byte:

Bit 0 CAN_CTRL : CAN bus communication control status

0 = The output voltage/current defined by control over SVR/PV/PC (factory default)

1 = The output voltage, current, ON/OFF control defined by control over CAN bus (VOUT_SET, IOUT_SET, OPERATION)

Bit 1:2 OPERATION_INIT : Pre-set value of power on operation command

0b00 = Power OFF, pre-set 0x00(OFF)

0b01 = Power ON, pre-set 0x01(ON) (factory default)

0b10 = Pre-set is previous set value

0b11 = Not used, reserved

High Byte:

Bit 0:1 EEP_CONFIG: EEPROM Configuration

0b00 = Immediate. Changes to parameters are written to EEPROM immediately (factory default)

0b01 = 1 minute delay. Write changes to EEPROM if all parameters remain unchanged for 1 minute

0b10 = 10 minute delay. Write changes to EEPROM if all parameters remain unchanged for 10 minutes

0b11 = Reserved

Bit 2 EEP_OFF: EEPROM storage function ON/OFF

0 = Enable. Parameters to be saved into EEPROM (factory default)

1 = Disable. Parameters NOT to be saved into EEPROM

Note: Unsupported settings display with "0"

©CLEAR_LOG (0x0910): The command clears the data stored in EVENT_0 to EVENT_4 (0x0921–0x0925). Event log data is stored in the EEPROM and remains intact after power off. To clear the event logs, write 0x00AA to CLEAR_LOG (0x0910). For example, to clear the event logs for the PSU at Address 00, the command format is as follows:

CAN ID	DLC (data length)	Command code	Parameters
0x000C0100	0x4	0x1009	0xAA00

Command code: 0x0910(CLEAR_LOG) → 0x10 (Lo) + 0x09 (Hi)

Parameters: 0x00AA → 0xAA (Lo) + 0x00 (Hi)

©EVENT_0 to EVENT_4 (0x0921–0x0925): Sequentially store the five most recent event logs. Refer to the table below for the mapping between event codes and their corresponding conditions.

Commands	Event (Decimal)	Event (Hexadecimal)	Event Description
EVENT_0 (0x0921)	0001	0x0001	Overload Protection (OLP)
	0002	0x0002	Over Voltage Protection (OVP)
	0006	0x0006	Short Circuit Protection (SCP)
EVENT_1 (0x0922)	4001	0x0FA1	Over Temperature Protection (OTP)
EVENT_2 (0x0923)			
EVENT_3 (0x0924)	4004	0x0FA4	Fan Fail Protection
EVENT_4 (0x0925)	4005	0x0FA5	Hardware Error
	4007	0x0FA7	EEPROM Error

The latest event is always stored in EVENT_0 (0x0921), and the remaining events are shifted accordingly from EVENT_1 (0x0922) to EVENT_4 (0x0925). When the number of events exceeds five, the oldest event is discarded from the event log. Refer to the table below for the sequence of events and data shifting logic.

Timing/Event Command	T1 (Earliest)	T2	T3	T4	T5	T6 (Latest)
	Fan Fail	OTP	SCP	OLP	OVP	OLP
EVENT_0 (0x0921)	4004	4001	0006	0001	0002	0001
EVENT_1 (0x0922)	0	4004	4001	0006	0001	0002
EVENT_2 (0x0923)	0	0	4004	4001	0006	0001
EVENT_3 (0x0924)	0	0	0	4004	4001	0006
EVENT_4 (0x0925)	0	0	0	0	4004	4001
Remark	4004 stored in EVENT_0	4001 stored in EVENT_0; existing logs shift	0006 stored in EVENT_0; existing logs shift	0001 stored in EVENT_0; existing logs shift	0002 stored in EVENT_0; existing logs shift	0001 stored in EVENT_0; existing logs shift; 4004 pushed out

6.1.3 Communication Examples

The following provides example of command sending and data reading for the CAN bus protocol.

6.1.3.1 Sending Command

The master adjusts output voltage of the unit with address "01" to 30V.

CAN ID	DLC (data length)	Command code	Parameters
0x000C0101	0x4	0x2000	0x2C01

Command code: 0x0020 (VOUT_SET) → 0x20(Lo) + 0x00(Hi)

Parameters: 30V → 300 → 0x012C → 0x2C(Lo) + 0x01(Hi)

Note: : Conversion factor for VOUT_SET is 0.1, so $\frac{30V}{F=0.1} = 300$

6.1.3.2 Reading Data or Status

The master reads operation setting from the unit with address "00".

CAN ID	DLC (data length)	Command code
0x000C0100	0x02	0x0000

The unit with address "00" returns data below:

CAN ID	DLC (data length)	Command code	Parameters
0x000C0000	0x3	0x0000	0x01

Parameters: 0x01 ON, meaning that the unit with address "00" is operating.

6.1.3.3 Practical Operation

The following steps will describe how to set the MSP-1600-48 to 56V.

- 1.Set the ID of the power supply to "0". Connect the A0(PIN 7), A1(PIN 8), and A2(PIN 9) to -Vo Signal (PIN 14), all on the CN1.

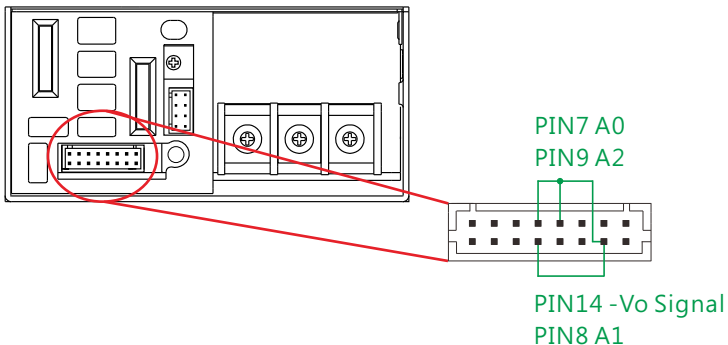

- 2.Connect the CANH/CANL pins of the master to the corresponding CANH(PIN7) and CANL(PIN8)pins of the CN2 connector on the power supply. It is recommended to establish a common ground for the communication system to increases its communication reliability by using GND-AUX (PIN2) of CN1.

◎Set baud rate: 250kbps, type: extended

◎Adding a 120Ω terminal resistor to both the controller and power supply ends can increase communication stability

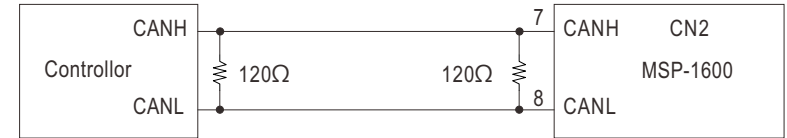

- 3.Configure communication settings after power on. Enable communication control mode and set power ON when AC connected.

CAN ID	DLC(data length)	Command Code	Parameters
0x000C0100	0x04	0xC200	0x0300

Command code: 0x00C2 (SYSTEM_CONFIG)

Data: 03(Lo) + 00(Hi) • Please refer to definition of SYSTEM_CONFIG for detailed information.

- 4.Set output voltage to 56V.

CAN ID	DLC(data length)	Command Code	Parameters
0x000C0100	0x04	0x2000	0x3002

Command code: 0x0020(VOUT_SET)

Data: 56V → 560 → 0x0230 → 0x30(Lo) + 0x02(Hi)

NOTE: Conversion factor for VOUT_SET is 0.1, so $\frac{56V}{F=0.1} = 560$

- 5.It is recommended to review all of the settings and parameters using the appropriate commands. In the event that they do not meet your requirements, you may rewrite them as needed. EX: Read VOUT_SET to check whether output voltage was set to a proper level.

Read VOUT_SET

CAN ID	DLC(data length)	Command Code
0x000C0100	0x02	0x2000

The unit returns data below

CAN ID	DLC(data length)	Command Code	Parameters
0x000C0000	0x04	0x2000	0x3002

Data: 0x30(Lo) + 0x02(Hi) → 0x0230 → 560 x 0.1 = 56V ·

6. Finally, check whether R.C (PIN 4) and +5-AUX (PIN 3) pins of the CN1 connector are short-circuited if there is no output voltage.

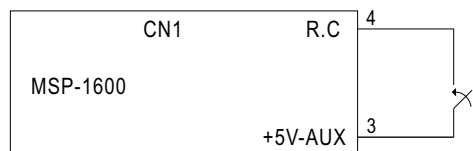

6.2 Value Range and Tolerance

(1) Display parameters

CAN bus Command	Model	Display value range	Tolerance	
0x0050	READ_VIN	ALL	80~264V	±10V
0x0060	READ_VOUT	12V	0~15V	±0.18V
		24V	0~30V	±0.36V
		36V	0~45V	±0.40V
		48V	0~60V	±0.48V
0x0061	READ_IOUT (Note)	12V	0~150A	±2.5A
		24V	0~80A	±1.34A
		36V	0~53.4A	±0.89A
		48V	0~40A	±0.67A
0x0062	READ_TEMPERATURE_1	ALL	-40~110°C	±5°C
0x0070	READ_FAN_SPEED_1	ALL	0~26500 RPM	±2000 RPM
0x0071	READ_FAN_SPEED_2	ALL	0~26500 RPM	±2000 RPM

(2) Control Parameters

CAN bus Command	Model	Programmable range	Tolerance	Default	
0x0000	OPERATION	ALL	00h(OFF)/01h(ON)	N/A	ON
0x0020	VOUT_SET	12V	1.8 ~ 13.8V	±0.18V	12V
		24V	3.6 ~ 27.6V	±0.36V	24V
		36V	5.4 ~ 41.4V	±0.40V	36V
		48V	7.2 ~ 55.2V	±0.48V	48V
0x0030	IOUT_SET	12V	25~137.5A	±2.5A	137.5A
		24V	13.4~73.7A	±1.34A	73.7A
		36V	8.9~49A	±0.89A	49A
		48V	6.7~36.9A	±0.67A	36.9A
0x00C2	SYSTEM_CONFIG	ALL	N/A	N/A	02h

Note:

i. READ_IOUT will display ZERO Amp when output current is less than values in the table below.

Model	Minimum readable current
12V	5A±1A
24V	2.7A±1A
36V	1.8A±1A
48V	1.3A±1A

ii. Owing to the limited write cycles of the EEPROM, it is advisable to consider using the SYSTEM_CONFIG (Command: 0x00C2) command to select an appropriate EEPROM writing logic, especially if communication settings are frequently altered.

7. Protections and Trouble Shooting

7.1 Protections

7.1.1 Over Load Protection (OLP)

When the load current exceeds the overload condition specified in the datasheet, the protection circuit will activate and shut down the output. To restore normal operation, the PSU must be restarted after the overload condition is cleared.

7.1.2 Over Voltage Protection (OVP)

When the output voltage exceeds the overvoltage threshold, the protection circuit will activate and shut down the output. To restore normal operation, the PSU must be restarted after the overvoltage condition is cleared.

7.1.3 Over Temperature Protection (OTP)

When the internal temperature exceeds the threshold, the output will shut down (while the fan continues to operate for cooling). To recover, turn off the AC power, eliminate any factors that may cause overheating, and allow the PSU to cool down to normal temperature (this may take several tens of minutes) before turning it back on. During OTP activation, the PSU outputs a T-ALARM signal (TTL, 10mA max). See the table below for details.

7.1.4 Fan Fail Protection

If the fan speed is detected as zero after power-on, the protection circuit will activate and shut down the output. Check for any obstructions that may interfere with fan rotation. After resolving the fan malfunction, the PSU must be restarted to restore normal operation. During Fan Fail activation, the PSU outputs a T-ALARM signal (TTL, 10mA max). See the table below for details.

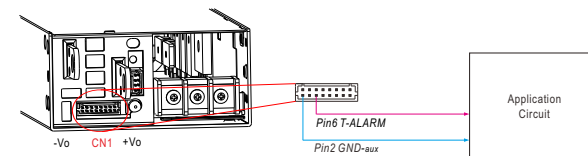

T-ALARM to GND-aux	SPS Status
3.5 ~ 5.5V (High)	Abnormal (OTP or fan fail)
-0.5 ~ 0.5V (Low)	Internal temperature and fan normal

7.1.5 Short Circuit Protection (SCP)

When the output is short-circuited, the protection circuit will activate and shut down the output. After clearing the short circuit condition, restart the PSU to restore normal operation.





7.1.6 AC Input Under-Voltage Protection (AC_UVP)

When the input voltage falls below the range specified in the datasheet, the protection circuit will activate and shut down the output. After the condition is cleared, restart the PSU to restore normal operation.

7.2 Trouble Shooting

The fault conditions listed in the table below can be identified by the LED indicator status. If the issue cannot be resolved, please contact your local authorized Mean Well distributor or the factory for assistance.

Category / Light Signal	Reason	Troubleshooting Suggestions
Remote OFF ● Red	CN1 PIN 4 (R.C) and PIN 3 (+5V-AUX) are not connected together.	Ensure that CN1 PIN 4 (R.C) is connected to PIN 3 (+5V-AUX).
High Ambient Temperature Alarm ☀ Red: Blink	Internal temperature at critical level. Unit still operational.	Ensure adequate ventilation clearance. Verify that input voltage and ambient temperature comply with the derating curve (Section 2.5) to prevent OTP.
Over Load Protection ☀ Red: 1 Blink/Pause 	The actual output current is higher than the rated current in the datasheet.	Remove the load and restart the device. If the unit recovers, gradually reapply the load while monitoring the output.

Category / Light Signal	Reason	Troubleshooting Suggestions
Over Voltage Protection ☀ Red: 2 Blink/Pause 	The output voltage exceeded the overvoltage threshold and shut down the output.	Ensure that no external DC power source is connected and that the voltage is within the OVP range specified in the datasheet.
Over Temperature Protection ☀ Red: 3 Blink/Pause 	Overheating of internal components.	Ensure adequate ventilation clearance. Verify that input voltage and ambient temperature comply with the derating curve (Section 2.5). Allow the PSU to cool to ambient temperature, then restart for testing.
Fan Fail Protection ☀ Red: 4 Blink/Pause 	No fan rotation was detected after power-on.	Check for foreign objects or other obstructions preventing fan rotation.
Other ☀ Red: 5 Blink/Pause 	1.Short circuit protection. 2.AC under voltage protects. 3.EEPROM error.	1.Check if there is short-circuit at the output. 2.Ensure that the input voltage is within the range specified in the datasheet. 3.If the above steps do not resolve the issue and the problem persists after restarting, there may be an internal fault. Contact your Mean Well distributor.

8. Warranty

This product provides 5 years warranty under normal usage. Do not replace parts or any form of modification to the product in order to keep the warranty effectively.

※ MEAN WELL possesses the right to adjust the content of this manual.

Please refer to the latest version of manual on our website.

<https://www.meanwell.com>



9. Environmental Declaration Information

https://www.meanwell.com/Upload/PDF/RoHS_PFOS.pdf

https://www.meanwell.com/Upload/PDF/REACH_SVHC.pdf

https://www.meanwell.com/Upload/PDF/Declaration_RoHS-E.pdf

明緯企業股份有限公司

MEAN WELL ENTERPRISES CO., LTD.

248 新北市五股區五權三路28號

No.28, Wuquan 3rd Rd., Wugu Dist., New Taipei City 248, Taiwan

Tel:886-2-2299-6100 Fax:886-2-2299-6200

<http://www.meanwell.com> E-mail:info@meanwell.com