



Slim Type with PFC Switching Power Supply

LSP-160 series



Features

- Slim width and low profile(20mm)
- Fanless design for noise free environment
- Withstand 300VAC surge input for 5 seconds
- DC OK active signal function
- Semi-Potting for high moisture environment
- Protections: Short circuit / Over load / Over voltage / Over temperature
- Current sharing for redundant function(5V/4.2V/3.3V only)
- Max. operating wattage to 200W at 230V AC input
- Operating altitude up to 5000 meter (Note.5)
- LED indicator for power on
- 3 years warranty

Applications

- Industrial automation machinery
- Industrial control system
- Mechanical and electrical equipment
- Electronic instruments, equipments or apparatus
- Household appliances
- LED display application

Description

LSP-160 series is a 200W Max. single-output slim type power supply with 20mm of low profile design. Adopting the full range 100~264VAC input, the entire series provides an output voltage line of 3.3V,4.2V,5V, 12V, 24V, 36V and 48V. In addition to the high efficiency up to 93.5%, that the whole series operates from -30°C ~ 70°C under air convection without fan. LSP-160 has the complete protection functions and 5G anti-vibration capability; It is complied with the international safety regulations such as TUV BS EN/EN62368, UL62368 and GB4943. LSP-160 series serves as a high performance power supply solution for various industrial applications.

Model Encoding

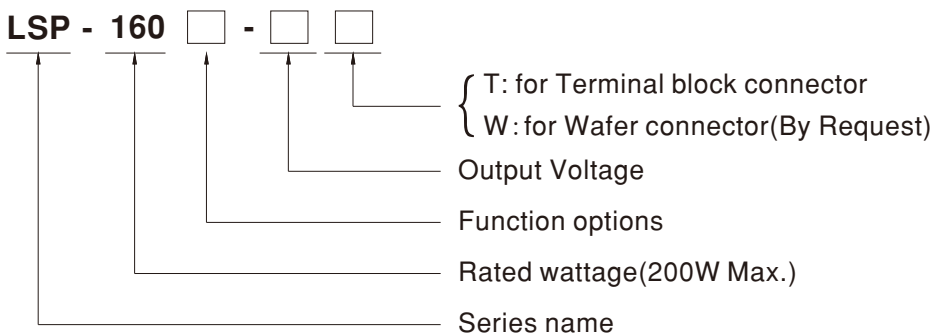

Type	Function	Note
Blank	Enclosed(DC voltage output)& Built-in DC OK active signal.	In Stock
R	Built-in DC OK active signal and current sharing function(3.3/4.2/5V).	In Stock

SPECIFICATION

MODEL		LSP-160□-3.3□	LSP-160□-4.2□	LSP-160□-5□	LSP-160-12□	LSP-160-24□	LSP-160-36□	LSP-160-48□
OUTPUT	DC VOLTAGE	3.3V	4.2V	5V	12V	24V	36V	48V
	RATED CURRENT Note.7	32A	32A	32A	13.5A	6.75A	4.5A	3.4A
		40A	40A	40A	16.68A	8.34A	5.56A	4.17A
	RATED POWER (convection) Note.7	105.6W	134.4W	160W	162W	162W	162W	163.2W
		132W	168W	200W	200.16W	200.16W	200.16W	200.16W
	RIPPLE & NOISE (max.) Note.2	200mVp-p	200mVp-p	200mVp-p	240mVp-p	240mVp-p	240mVp-p	300mVp-p
	VOLTAGE ADJ. RANGE	3.2~3.5V	4~4.5V	4.7~5.3V	11.4~12.6V	22.8~25.2V	34.2~37.8V	45.6~50.4V
	VOLTAGE ADJ. RANGE for 200W	3.2~3.3V	4~4.2V	4.7~5V	11.4~12V	22.8~24V	34.2~36V	45.6~48V
	VOLTAGE TOLERANCE Note.3	±2.0%	±2.0%	±2.0%	±1.0%	±1.0%	±1.0%	±1.0%
	LINE REGULATION	±0.5%	±0.5%	±0.5%	±0.3%	±0.3%	±0.3%	±0.3%
LOAD REGULATION	±1.0%	±1.0%	±1.0%	±0.5%	±0.5%	±0.5%	±0.5%	
SETUP, RISE TIME	2000ms, 110ms/230VAC 3000ms, 110ms/115VAC at full load							
HOLD UP TIME (Typ.)	8ms/230Vac 8ms/115VAC							
INPUT	VOLTAGE RANGE Note.4	100 ~ 264VAC 141 ~ 370VDC						
	FREQUENCY RANGE	47 ~ 63Hz						
	POWER FACTOR (Typ.)	PF ≥ 0.94/230VAC PF ≥ 0.98/115VAC at full load						
	EFFICIENCY (Typ.)	87.5%	87.5%	89.5%	92.5%	93.5%	93.5%	93.5%
	AC CURRENT (Typ.)	2.2A/115VAC 1.1A/230VAC						
	INRUSH CURRENT (Typ.)	Cold start 45A/115VAC 85A/230VAC						
	LEAKAGE CURRENT	<0.75mA / 240VAC						
PROTECTION	SHORT CIRCUIT	Hiccup protection, recovers automatically after fault condition is removed						
	OVER LOAD	130 ~ 150% rated output power (based on 160W)						
		Protection type : Constant current limiting, continuous increase of load will be hiccup protection, recovers automatically after fault condition is removed						
	OVER VOLTAGE	3.8~4.6V	4.62~5.46V	5.75~6.75V	13.2~15.6V	26.4~31.2V	39.6~46.8V	52.8~62.4V
OVER TEMPERATURE	Shut down O/P voltage, re-power on to recover after temperature goes down							
FUNCTION	CURRENT SHARING	Please refer to the Function Manual						
	DC OK SIGNAL	Contact rating(max.):15Vdc/10mA resistive load						
ENVIRONMENT	WORKING TEMP.	-30 ~ +70°C (Refer to "Derating Curve")						
	WORKING HUMIDITY	20 ~ 90% RH non-condensing						
	STORAGE TEMP., HUMIDITY	-40 ~ +85°C, 10 ~ 95% RH non-condensing						
	TEMP. COEFFICIENT	±0.03%/°C (0 ~ 50°C)						
	VIBRATION	10 ~ 500Hz, 5G 10min./1cycle, 60min. each along X, Y, Z axes						
SAFETY & EMC (Note.6)	SAFETY STANDARDS	UL62368, TUV BS EN/EN62368, CCC GB4943.1, EAC TP TC 004, BSMI CNS14336-1 approved, Design refer to BS EN/EN60335-1						
	WITHSTAND VOLTAGE	I/P-O/P:3.75KVAC I/P-FG:2KVAC O/P-FG:1.25KVAC						
	ISOLATION RESISTANCE	I/P-O/P, I/P-FG, O/P-FG:100M Ohms/500VDC/25°C/70%RH						
	EMC EMISSION	Compliance to BS EN/EN55032, GB17625.1, GB/T 9254.1, Class B, BS EN/EN55014, BS EN/EN61000-3-2, -3, EAC TP TC 020, BSMI CNS13438						
	EMC IMMUNITY	Compliance to BS EN/EN61000-4-2, 3, 4, 5, 6, 8, 11; BS EN/EN61000-6-2 (BS EN/EN50082-2), BS EN/EN55035, heavy industry level, criterial A, EAC TP TC 020						
OTHERS	MTBF	699.54K hrs min. Telcordia TR/SR-332(Bellcore); 282.71K hrs min. MIL-HDBK-217F (25°C)						
	DIMENSION	194*55*20mm (L*W*H)						
	PACKING	0.356kg; 30pcs/11.68kg/0.6CUFT						
NOTE	<p>1. All parameters NOT specially mentioned are measured at 230VAC input, rated load and 25°C of ambient temperature.</p> <p>2. Ripple & noise are measured at 20MHz of bandwidth by using a 12" twisted pair-wire terminated with a 0.1uf & 47uf parallel capacitor.</p> <p>3. Tolerance: includes set up tolerance, line regulation and load regulation.</p> <p>4. Derating may be needed under low input voltages. Please check the derating curve for more details.</p> <p>5. The ambient temperature derating of 5°C/1000m is needed for operating altitude greater than 2000m(6500ft)</p> <p>6. The power supply is considered a component which will be installed into a final equipment. The final equipment must be re-confirmed that it still meets EMC directives. For guidance on how to perform these EMC tests, please refer to "EMI testing of component power supplies." (as available on https://www.meanwell.com/Upload/PDF/EMI_statement_en.pdf)</p> <p>7. The maximum operate wattage up to 200W at 200~264VAC input and -20~50°C ambient temperature with aluminum plate, MEANWELL can guarantee the lifetime and offer 3 years warranty.</p> <p>※ Product Liability Disclaimer : For detailed information, please refer to https://www.meanwell.com/serviceDisclaimer.aspx</p>							

■ Block Diagram

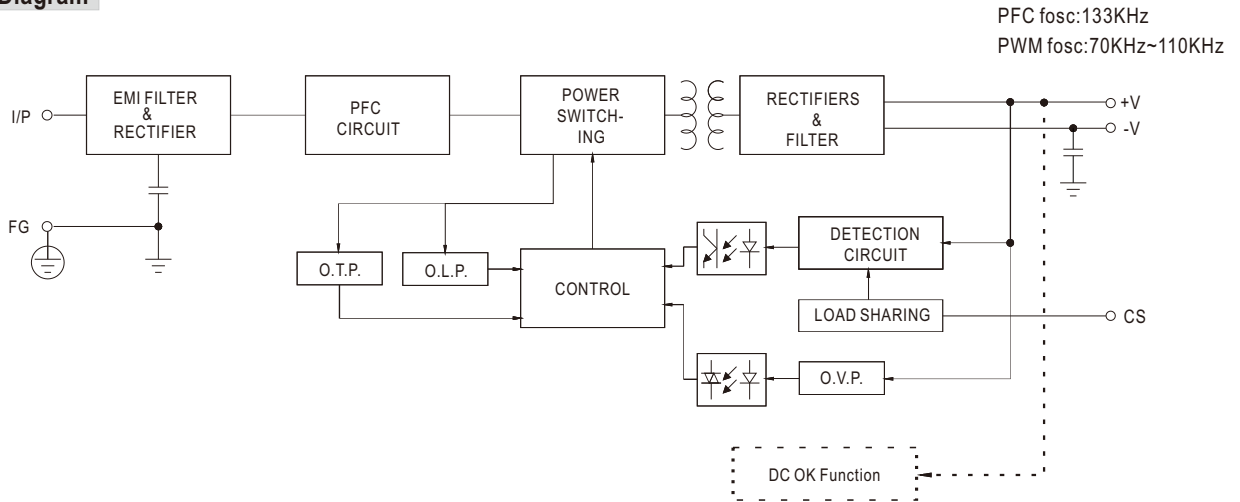

■ Derating Curve

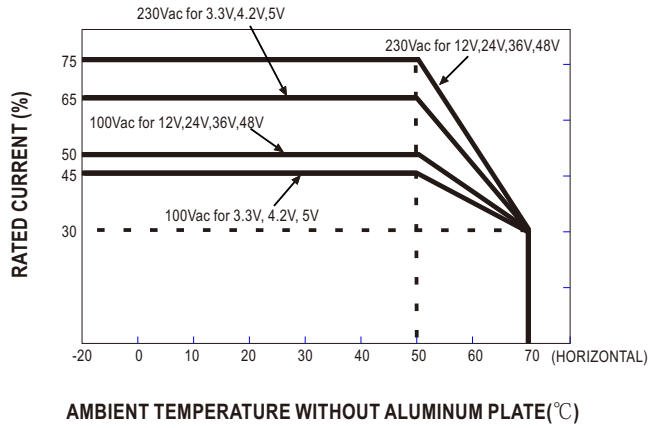
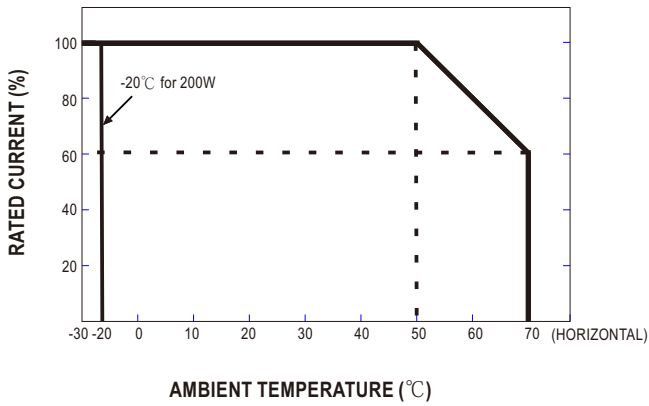

■ STATIC CHARACTERISTIC

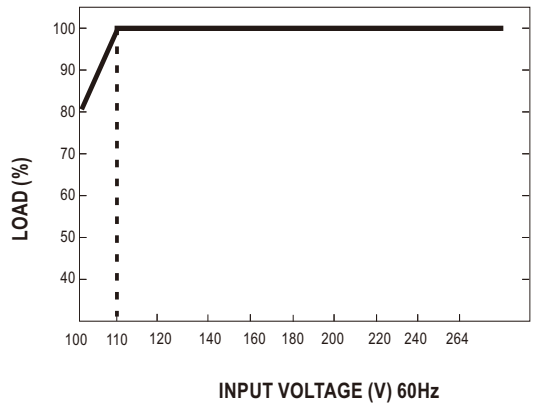
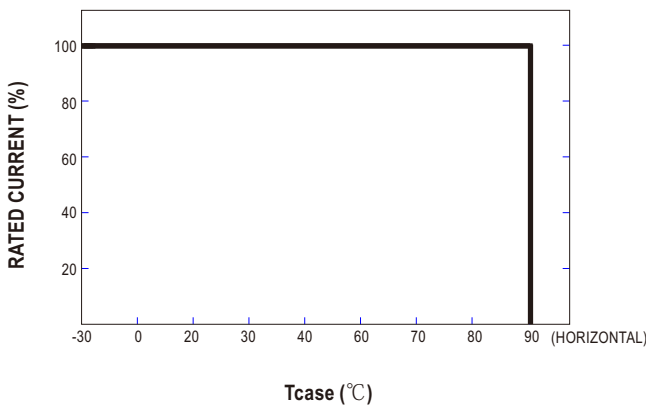

NOTE: Tc measurement point ,please refer page 5 mechanical specification.

Function Manual

1. DC_OK Signal

DC_OK is a collector shorted signal. It is used by an optocoupler in the power supply which indicates the output status of the power supply as exhibited below.

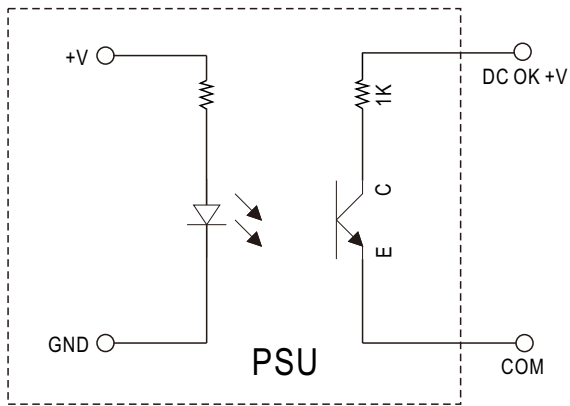

Optocoupler C-E Pin Conduction	PSU turns on	DC ok
Optocoupler C-E Pin Open	PSU turns off	DC fail
Optocoupler Rating(max.)	15Vdc/10mA resistive load	

Power Status	DC_OK signal
Normal	Low
Short circuit/OLP	Hiccup
OVP/OTP/Breakingdown	High

2. Redundant function:

LSP-160 has built-in redundant function and can be connected 2 units in parallel for current sharing.

- ※ Difference of output voltages among parallel units should be less than 0.2V(Can Fine tune by SVR1).
- ※ When in parallel operation the maximum load should not be greater than the rated power.
- ※ When output current < (30% rate current) × (Number of unit), the current shared among units may not be fully balanced. And the LED indicator maybe flash of one of them, but not effecting normal working.

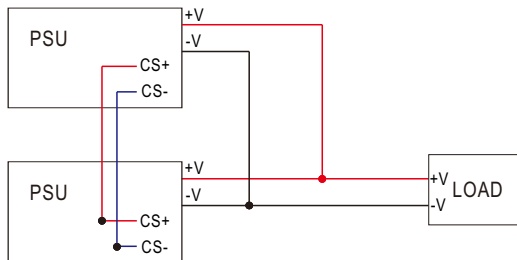

◎ CS+/CS- on CN1 are connected mutually in parallel(Note:CS+/CS- do not reverse connection).

Mechanical Specification

CASE NO.:279 Unit:mm Tolerance:±1

※ T-type(Terminal block)

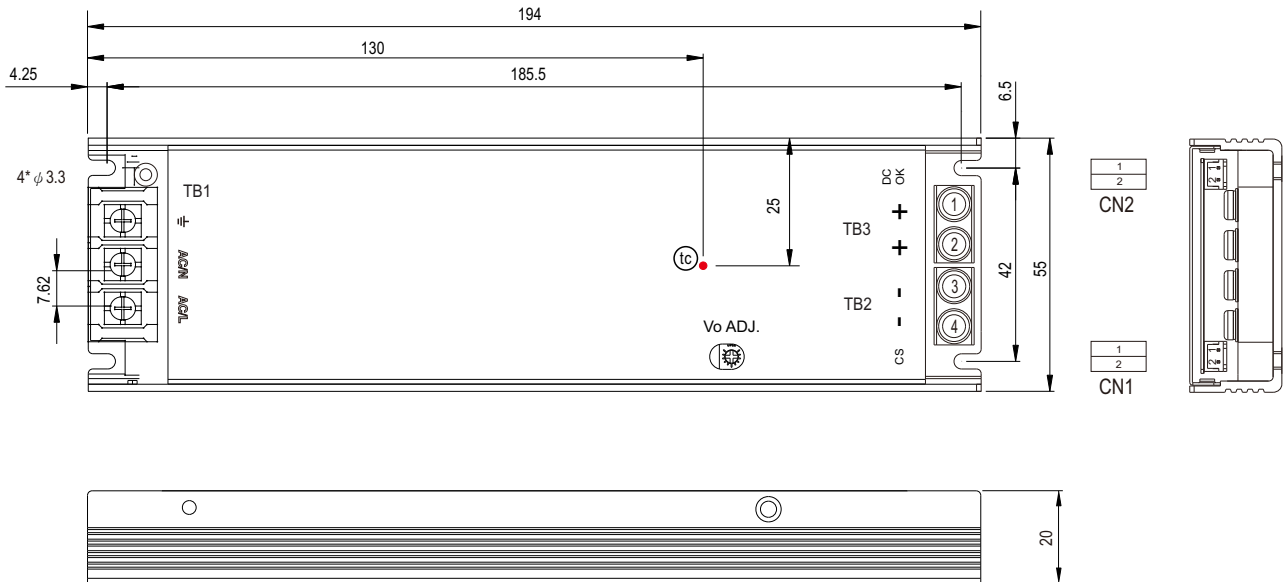

AC Input Connector(TB1) pin NO. Assignment

Pin No.	Assignment	Terminal	Max mounting torque
1	AC/L	(DEGSON) DG28C-B-03P	5Kgf-cm
3	AC/N		
5	⊥		

DC Output Connector(TB2/TB3)pin NO. Assignment

Pin No.	Assignment	Terminal	Max mounting torque
1,2	+V	(MW) TB-HTP-200-40A	8Kgf-cm
3,4	-V		

DC OK Connector(CN2):JST B2B-PH-K-S or equivalent

Pin No.	Assignment	Mating Housing	Terminal
1	DC OK +V	JST SPH-002T-P0.5S or equivalent	JST PHR-2 or equivalent
2	DC COM		



CS+/CS- Connector(CN1):JST B2B-PH-K-S or equivalent

Pin No.	Assignment	Mating Housing	Terminal
1	CS+	JST PHR-2 or equivalent	JST SPH-002T-P0.5S or equivalent
2	CS-		

CN mating cable: 1FF5LSP-160-CS(Optional)

© CN1 and CN2 mating cable by request, please consult MEANWELL for details

CASE NO.:279 Unit:mm Tolerance:±1

※ W-Type(Wafer connector type optional)

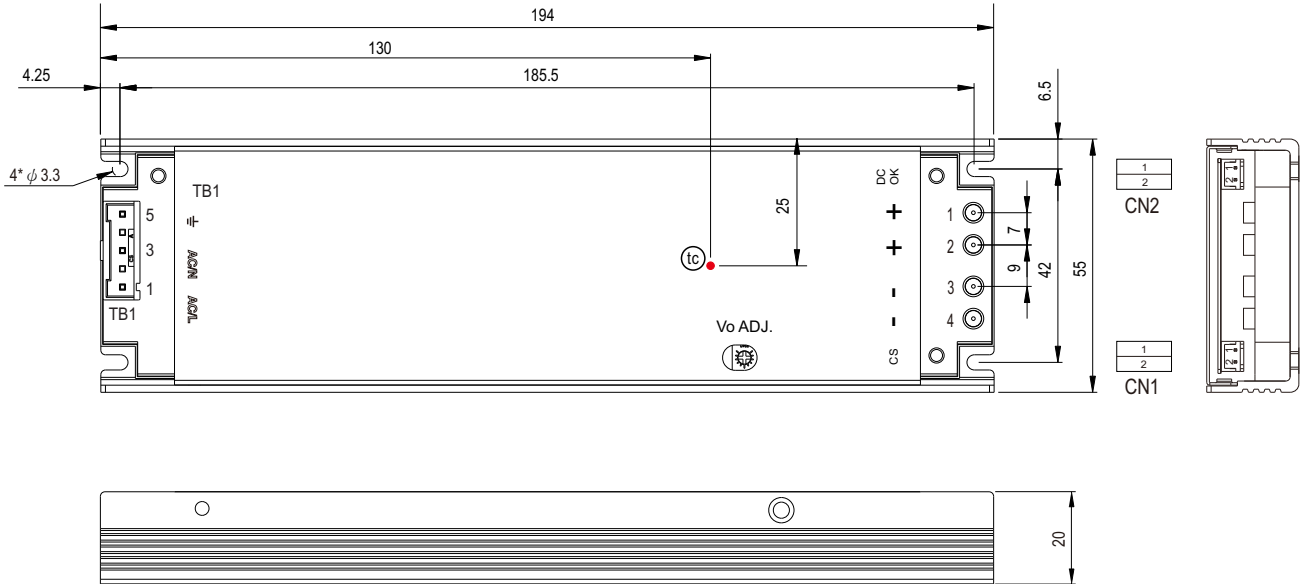

AC Input Connector(TB1) pin NO. Assignment

Pin No.	Assignment	Mating housing	Terminal
1	AC/L	JS-1391-05	JS-1390-05 and JS-2420-TL
3	AC/N		
5	⏏		

DC Output Connector(+V/-V)pin NO. Assignment

Pin No.	Assignment	Mating housing	Terminal
1,2	+V	1EE4LSP-160F	1EE4LSP-160M
3,4	-V		

DC OK Connector(CN2):JST B2B-PH-K-S or equivalent

Pin No.	Assignment	Mating Housing	Terminal
1	DC OK +V	JST SPH-002T-P0.5S or equivalent	JST PHR-2 or equivalent
2	DC COM		



CS+/CS- Connector(CN1):JST B2B-PH-K-S or equivalent

Pin No.	Assignment	Mating Housing	Terminal
1	CS+	JST PHR-2 or equivalent	JST SPH-002T-P0.5S or equivalent
2	CS-		

CN mating cable: 1FF5LSP-160-CS(Optional)

© CN1 and CN2 mating cable by request, please consult MEANWELL for details

■ Installation

1. Operate with additional aluminum plate

In order to meet the "Derating Curve" and the "Static Characteristics", LSP-160 series must be installed onto an aluminum plate (or the cabinet of the same size) on the bottom. The size of the suggested aluminum plate is shown as below. And for optimizing thermal performance, the aluminum plate must have an even and smooth surface (or coated with thermal grease), and LSP-160 series must be firmly mounted at the center of the aluminum plate.

unit:mm

