



Front Panel
(DC Input Side)



Back Panel
(DC Output Side)



■ Features

- Wide input voltage range 10~60VDC / 60~380VDC by models
- High efficiency up to 91%
- Modular design for flexible configuration
- Flexible CC/CV/CP operation modes
- Remote control and monitoring by CANBus protocol via CMU2A control console
- Maximum 64 units ERS-1400 series that can be connected
- Protections: Over voltage / Under voltage / Over temperature / Communication error
- 5 years warranty

■ Applications

- Battery test or power supply aging system
- Energy recycling system
- Connector mechanical test

■ GTIN CODE

MW Search: <https://www.meanwell.com/serviceGTIN.aspx>

■ Description

ERS-1400 series is an DC energy recycling power unit that supports 1400W rated input, it can achieve high efficiency up to 91%. CC and CV/CP modes selectable and 4 input channels design that can be used independently or connected in series or parallel offer flexible combinations for various applications. Moreover, the system also provides remote control and monitoring functions by using CMU2A or the CANBus protocol for data analysis and remote monitor. ERS-1400 supports 10~60VDC input voltage & ERS-1400H supports 60~380VDC input voltage.

■ Model Encoding

ERS - 1400 H

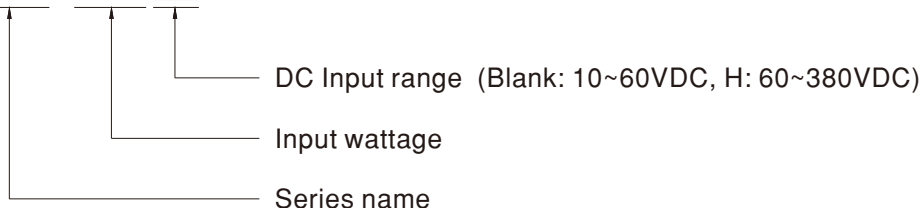

※ Note: Control / Monitor unit, CMU2 available. Details on <https://www.meanwell.com/>
Order No. CMU2A-#R#



SPECIFICATION (Note.1)

MODEL		ERS-1400	ERS-1400H
DC INPUT	RATED INPUT POWER (Typ.)	1200 ~ 1440W (for input 10 ~ 12VDC) 1440W (for input 12 ~ 60VDC)	864 ~ 1440W (for input 60 ~ 100VDC) 1440W (for input 100 ~ 380VDC)
	INPUT VOLTAGE RANGE	10 ~ 60VDC	60 ~ 380VDC
	RATED INPUT CURRENT (Typ.)	30A*4CH	3.6A*4CH
	EFFICIENCY (Typ.)	91% @ 48V input	90% @ 380V input
DC OUTPUT	VOLTAGE	320VDC	
	VOLTAGE TOLERANCE	±2%	
	RIPPLE & NOISE (max.)	4V	
	OUTPUT CURRENT (max.)	6.3A	
	ENERGY RECYCLING RATIO (Typ.)	85%@48VDC input/1440W (power supply efficiency ≥ 95%) Please refer to page 3 energy recycling ratio for more detail	85%@380VDC input/1440W (power supply efficiency ≥ 96%)
AC INPUT	VOLTAGE RANGE	180 ~ 264VAC	
	FREQUENCY RANGE	47 ~ 63Hz	
	POWER FACTOR	0.97/230VAC	
	INRUSH CURRENT (Typ.)	50A /230VAC	
PROTECTION	OVER TEMPERATURE	Shuts down DC output voltage, reset after fault condition removed	
	DC INPUT OVER VOLTAGE	Shuts down DC output voltage, reset after fault condition removed	
	DC INPUT UNDER VOLTAGE	Shuts down DC output voltage, reset after fault condition removed	
	COMMUNICATION ERROR	Shuts down AC output voltage after communication is failed for 4s. Reset after communication is re-built	
	OVER POWER	Constant power limiting at MAX input power	
FUNCTION	COMMUNICATION INTERFACE	CANBus, Baud Rate 250k bps (Maximum 64 units ERS-1400 series)	
	CC/CV/CP MODE SELECT (Note.2)	CONSTANT CURRENT (CC) : 0.5~30A(±1%) / per. channel	CONSTANT CURRENT (CC) : 0.5~3.6A(±1%) / per. channel
		-----	CONSTANT VOLTAGE (CV) : 60~380VDC (±10V)
		CONSTANT POWER (CP) : 5~360W (±5%) / per. channel	-----
PARALLEL	Please refer to function manual and user manual for more detail		
ENVIRONMENT	WORKING TEMP.	-20 ~ +60°C	
	WORKING HUMIDITY	20% ~ 90% RH non-condensing	
	STORAGE TEMP., HUMIDITY	-40 ~ +85°C, 10 ~ 95% RH	
SAFETY & EMC (Note. 4)	SAFETY STANDARDS	BS EN/EN62368-1 approved	
	EMC EMISSION Note.3	Compliance to BS EN/EN55032 (CISPR32)	
	EMC IMMUNITY Note.3	Compliance to BS EN/EN61000-4-2,3,4,5,6,8,11 light industry level, criteria A	
OTHERS	MTBF	ERS-1400: 260.3K hrs min. Telcordia SR-332 (Bellcore) ; 29.4K hrs min. MIL-HDBK-217F (25°C) ERS-1400H: 264.2K hrs min. Telcordia SR-332 (Bellcore) ; 27.7K hrs min. MIL-HDBK-217F (25°C)	
	COOLING	Internal fan cooling	
	DIMENSION	450*213*63.5mm(L*W*H)	
	PACKING	5.76Kg; 2pcs/12.5Kg/1.68CUFT	
NOTE	<p>1.All parameters NOT specially mentioned are measured at 320VDC output,48VDC input (ERS-1400),380VDC input(ERS-1400H),rated input power and 25°C of ambient temperature.</p> <p>2.Tolerances are calculated based on MAX input current and MAX input voltage. Tolerances may increase during high and low ambient temperature operation.</p> <p>3.Guidance of additional filter, please refer to user manual for more detail.</p> <p>4.The power supply is considered a component which will be installed into a final equipment. All the EMC tests are been executed by mounting the unit on a 900mm*1300mm metal plate with 2mm of thickness. The final equipment must be re-confirmed that it still meets EMC directives. For guidance on how to perform these EMC tests, please refer to "EMI testing of component power supplies." (as available on https://www.meanwell.com/Upload/PDF/EMI_statement_en.pdf)</p> <p>※ Product Liability Disclaimer : For detailed information, please refer to https://www.meanwell.com/serviceDisclaimer.aspx</p>		

Block Diagram

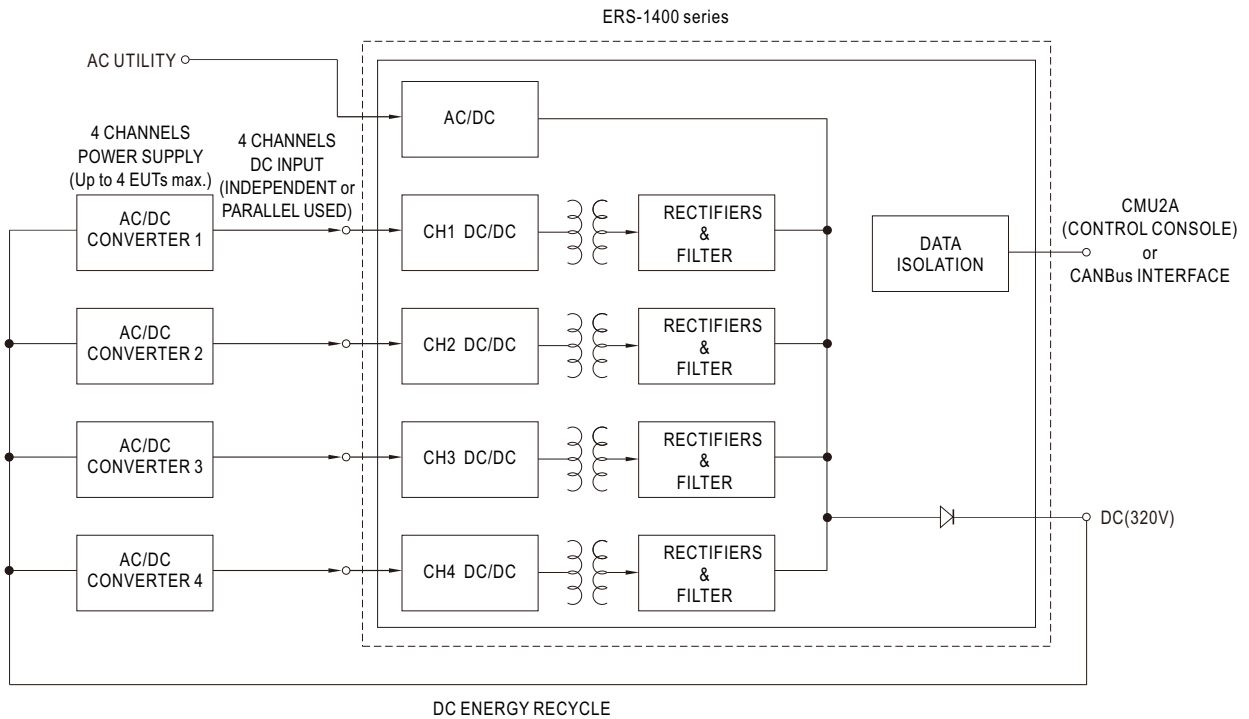

EFFICIENCY vs LOAD

※ ERS-1400 model

Efficiency measured at 48VDC input and 25°C of ambient temperature

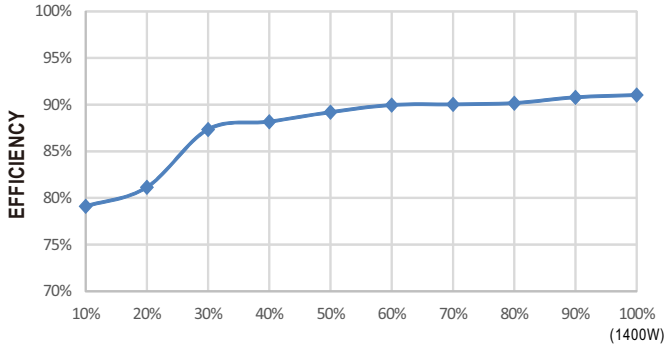

※ ERS-1400H model

Efficiency measured at 380VDC input and 25°C of ambient temperature

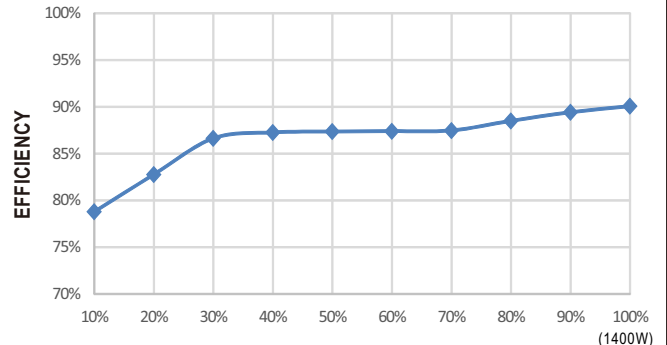

Energy Recycling Ratio Calculation

※ Energy recycling ratio = Efficiency 1 (power supply) x Efficiency 2 (ERS-1400 series)

Static Characteristics

※ ERS-1400 model

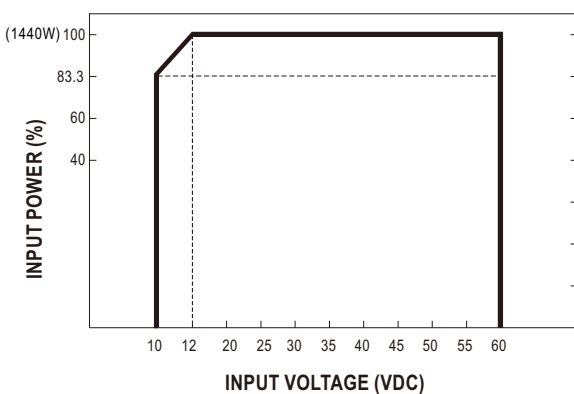

※ ERS-1400H model

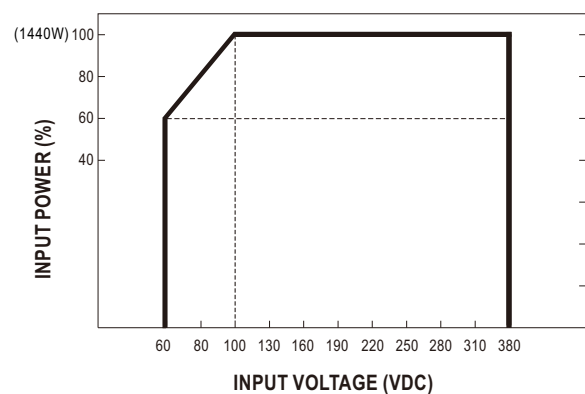

Mechanical Specification

Case No. ERS-1400 Unit:mm Tolerance:±1

© ERS-1400 series

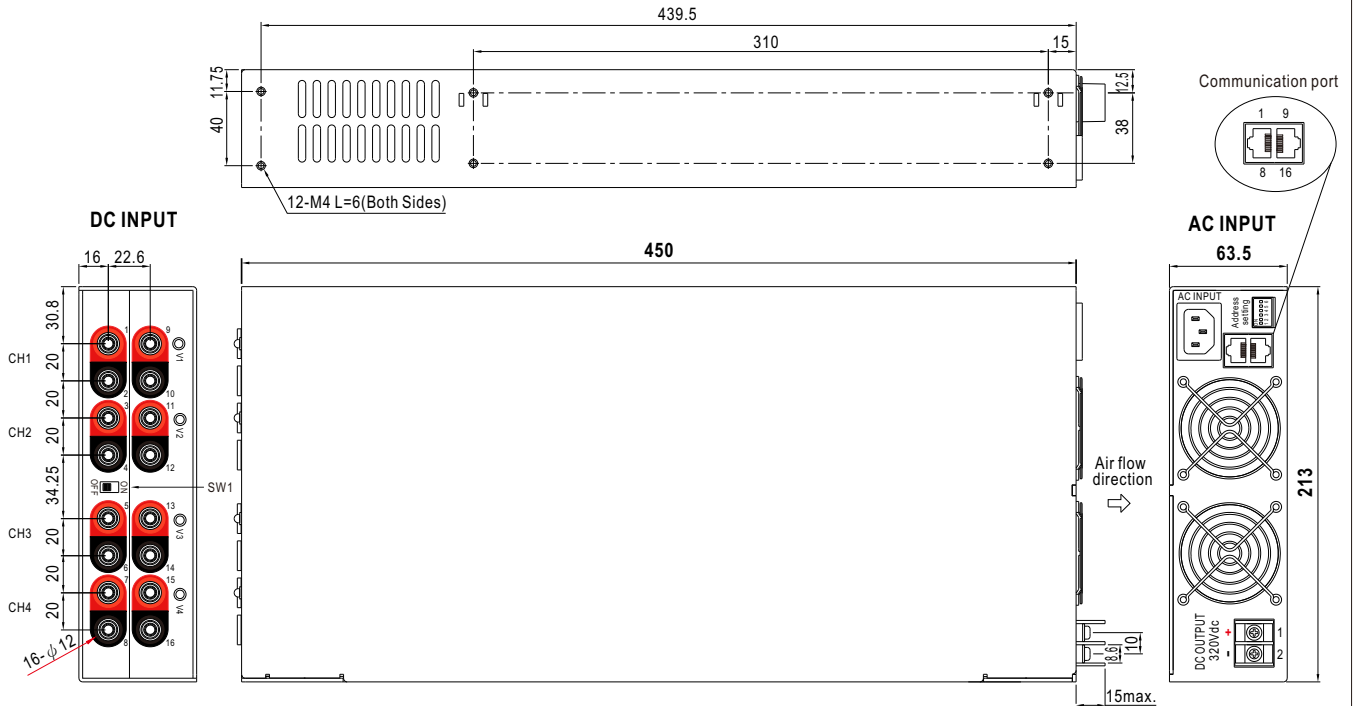

※ Communication port Pin No. Assignment :

Pin No.	Function	Description
1,9	CANH	Data line used in CANBus interface
2,10	CANL	Data line used in CANBus interface
3,11	NC	Retain for future use
4,12	FG	Reference ground for CANBus interface
5,6,7,8,13 14,15,16	NC	Not use

※ V1~V4 LED Status Indicators

LED	Description
● LED OFF	No AC utility connected
● Steady Green	Normal operating
● Flashing Green	Abnormal status

※ Address setting

For CANBus interface address setting, please refer to the user manual for more details

※ DC OUTPUT Pin No. Assignment :

Pin No.	Function	Description	Diagram	Maximum mounting torque
1	HV+	320Vdc +		18Kgf-cm
2	HV-	320Vdc -		

※ DC Input Pin No. Assignment : PRO-TEN 5.7mm NEWSOK PCB mount assembly or equivalent

Pin No.	Function	Description	Mating Housing
1,3,5,7,9, 11,13,15	+V	Positive end of DC input CH1: PIN1 & 9, CH2: PIN3 & 11, CH3: PIN5 & 13, CH4: PIN7 & 15	PRO-TEN 5.7mm NEWSOK SURLOK PIN or equivalent
2,4,6,8, 10,12,14,16	-V	Negative end of DC input CH1: PIN2 & 10, CH2: PIN4 & 12, CH3: PIN6 & 14, CH4: PIN8 & 16	PRO-TEN 5.7mm NEWSOK SURLOK PIN or equivalent

※ Address setting Pin No. Assignment :

Function	Description
ON	ERS-1400 DC input voltage in series (for CH1 PIN 1&2, CH2 PIN 3&4, CH3 PIN 5&6, CH4 PIN 7&8)
OFF	ERS-1400 DC input voltage in dependent (for CH1 PIN 9&10, CH2 PIN 11&12, CH3 PIN 13&14, CH4 PIN 15&16)

■ Function Manual

1. Energy Recycle Burn-in System Diagram

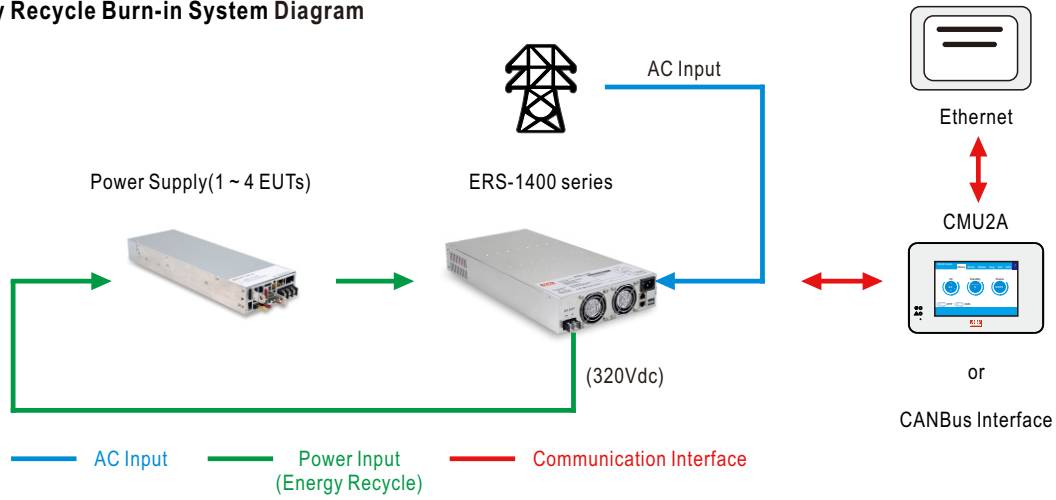

2. Front Panel Connection Diagram

Note : Select suitable wires for connection between the power supply(EUTs) and the ERS-1400 series to reduce line loss and increase energy recycling ratio.

(1) SW1 turn OFF ON
 OFF

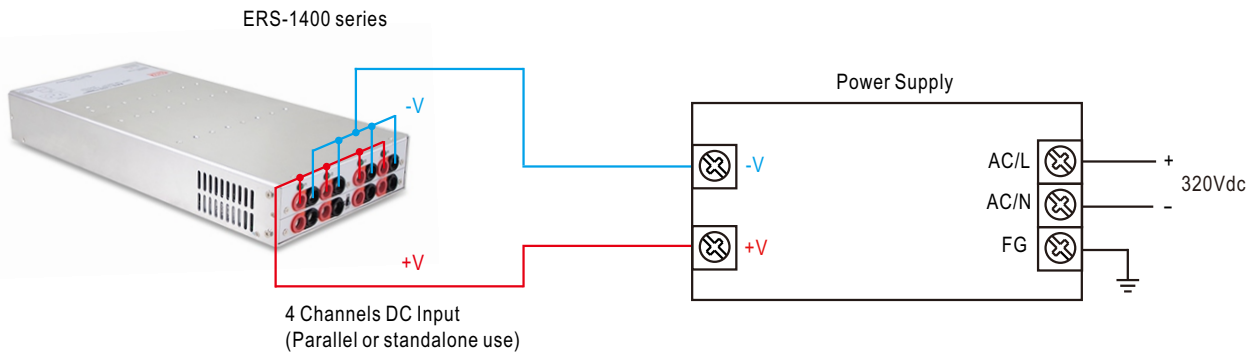

(2) SW1 turn ON ON
 OFF : (Increase burn-in power configuration)

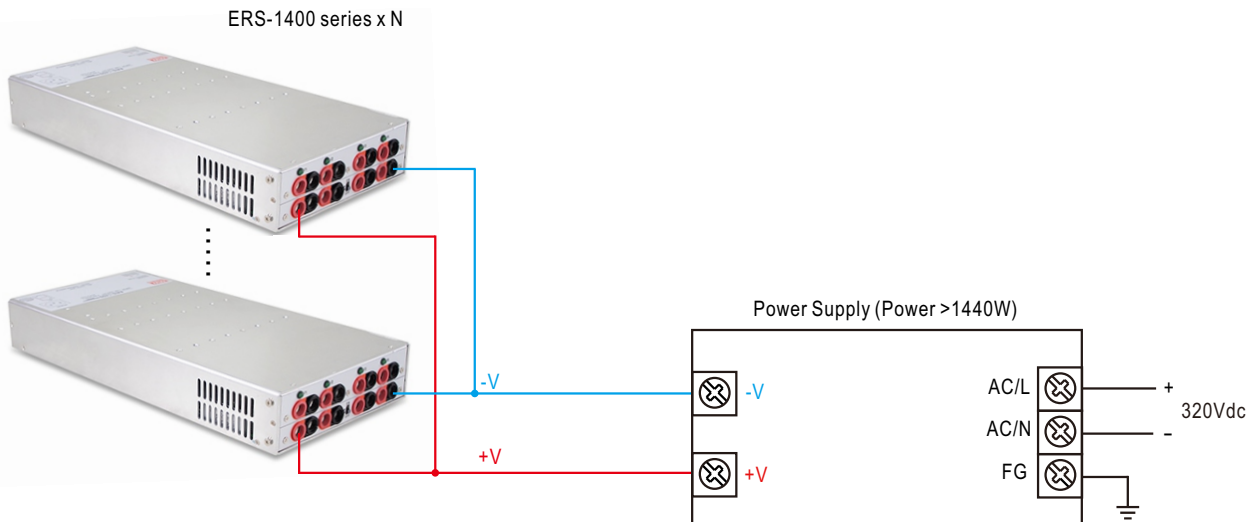

(3)SW1 turn ON (Increase burn-in voltage configuration)

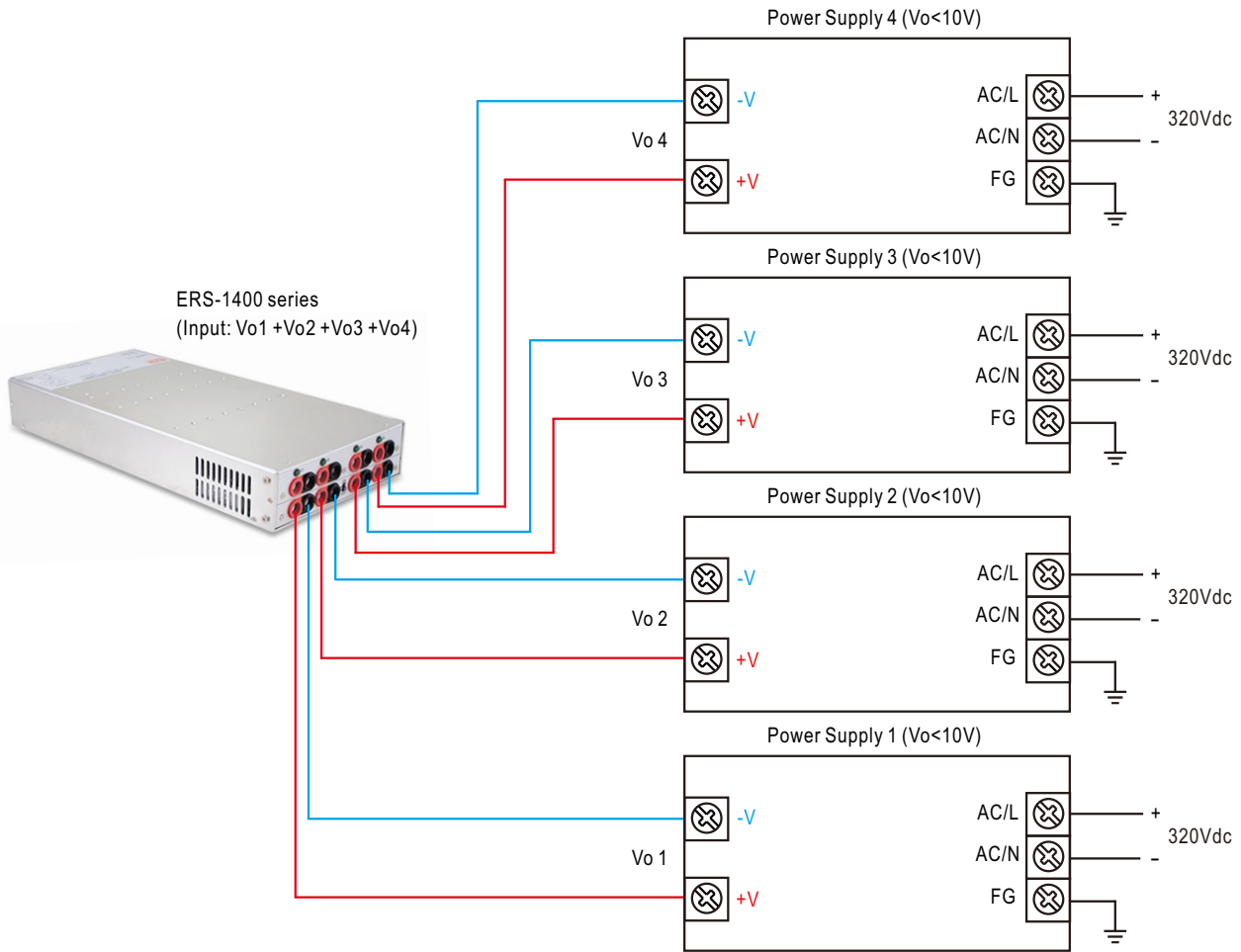

3. Back Panel Connection Diagram

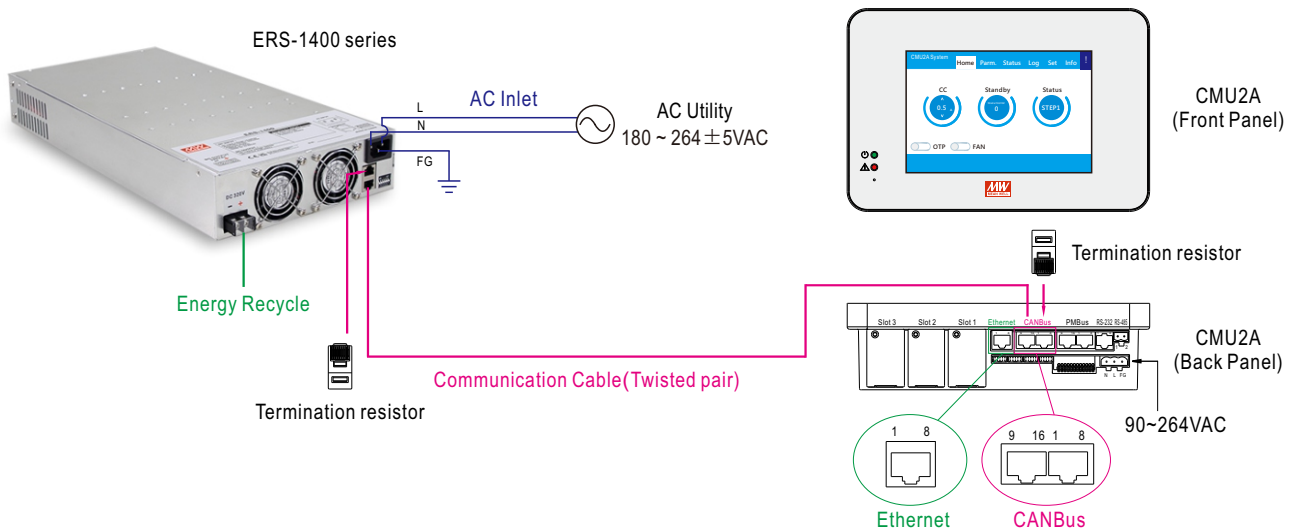

Note : After connecting the communication cable, install termination resistors to the remaining sockets of both the ERS-1400 series and CMU2A to prevent signal reflections.

■ Accessory List

If optional wire is in need, please contact MEAN WELL for details.

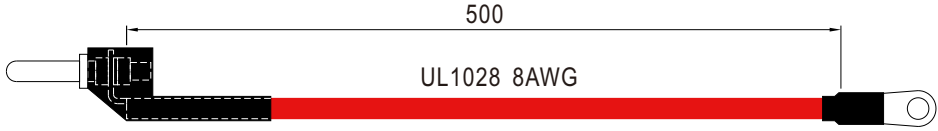
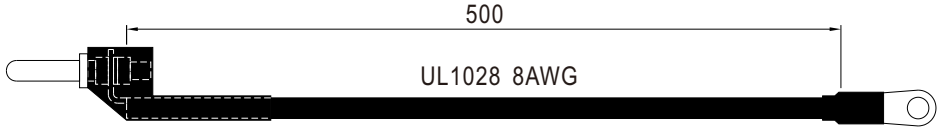
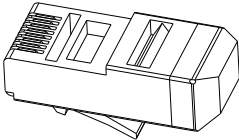
	Item	Quantity
①	<p>Red wire for +V connector, ordering No.: PFF5NEWSOK-500RED</p> 	4
②	<p>Black wire for -V connector, ordering No.: PFF5NEWSOK-500BK</p> 	4
③	<p>Termination resistor</p> 	1