

■ Features

■ Applications

- 5"×3" compact size
- 320W convection, 500W force air
- 550W peak power (3sec.)
- EMI for both Class I & Class II configuration
- -30~+70°C wide range operating temperature
- No load power consumption < 0.5W by PS_ON control
- High efficiency up to 94%
- Protections: Short circuit / Overload / Over voltage / Over temperature
- 5Vdc standby output, 12Vdc fan supply, Power Good, Power Fail and remote sense
- Operating altitude up to 5000 meters (Note.5)
- LED indicator for power on
- 3 years warranty

- Industrial automation machinery
- Industrial control system
- Mechanical and electrical equipment
- Electronic instruments, equipments or apparatus
- Power sourcing equipment of PoE

■ GTIN CODE

MW Search: <https://www.meanwell.com/serviceGTIN.aspx>

■ Description

EPP-500 is a 500W highly reliable green PCB type power supply with a high power density on the 5" by 3" footprint. It accepts 80~264VAC input and offers various output voltages between 12V and 54V. The working efficiency is up to 94% and the extremely low no load power consumption is down below 0.5W. EPP-500 is able to be used for both Class I (with FG) and Class II (no FG) system design. EPP-500 has complete protection functions; it is complied with the international safety regulations such as TUV BS EN/EN62368-1, TUV BS EN/EN60335-1, UL62368-1 and IEC62368-1. EPP-500 series serves as a high price-to-performance power supply solution for various industrial applications.

■ Model Encoding

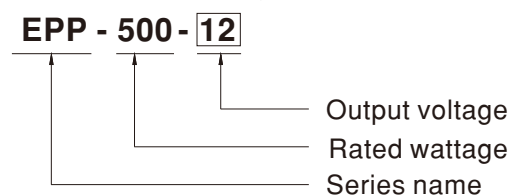



SPECIFICATION

MODEL		EPP-500-12	EPP-500-15	EPP-500-18	EPP-500-24	EPP-500-27	EPP-500-36	EPP-500-48	EPP-500-54	
OUTPUT	DC VOLTAGE	12V	15V	18V	24V	27V	36V	48V	54V	
	CURRENT	25CFM	41.6A	33.3A	27.8A	20.8A	18.5A	13.9A	10.4A	9.26A
		Convection	26.7A	21.3A	17.8A	13.4A	11.9A	8.9A	6.7A	5.93A
	RATED POWER <small>Note.5</small>	25CFM	499.2W	499.5W	500.4W	499.2W	499.5W	500.4W	499.2W	500W
		Convection	320.4W	319.5W	320.4W	321W	321.3W	320.4W	321.6W	320.2W
	PEAK POWER(3sec.)	550W								
	RIPPLE & NOISE (max.) <small>Note.2</small>	200mVp-p								
	VOLTAGE ADJ. RANGE(MAIN OUTPUT)	11.4~12.6V	14.3~15.8V	17.1~18.9V	22.8~25.2V	25.6 ~ 28.4V	34.2 ~37.8V	45.6 ~50.4V	51 ~56V	
	VOLTAGE TOLERANCE <small>Note.3</small>	±3.0%	±3.0%	±3.0%	±2.0%	±2.0%	±1.0%	±1.0%	±1.0%	
	LINE REGULATION	±0.5%	±0.5%	±0.5%	±0.5%	±0.5%	±0.5%	±0.5%	±0.5%	
	LOAD REGULATION	±1.0%	±1.0%	±1.0%	±1.0%	±1.0%	±1.0%	±1.0%	±1.0%	
SETUP, RISE TIME	1000ms, 30ms/230VAC			1500ms, 30ms/115VAC at full load						
HOLD UP TIME (Typ.)	10ms/230VAC			10ms/115VAC at full load						
INPUT	VOLTAGE RANGE <small>Note.4</small>	80 ~ 264VAC		113 ~ 370VDC						
	FREQUENCY RANGE	47 ~ 63Hz								
	POWER FACTOR	PF>0.94/230VAC PF>0.98/115VAC at full load								
	EFFICIENCY (Typ.)	91%	92%	92.5%	93%	93.5%	94%	94%	94%	
	AC CURRENT (Typ.)	5.8A/115VAC		2.9A/230VAC						
	INRUSH CURRENT (Typ.)	COLD START 40A/115VAC			80A/230VAC					
	LEAKAGE CURRENT	<0.75mA / 240VAC								
PROTECTION	OVERLOAD	105 ~ 135% rated output power Protection type : Hiccup mode, recovers automatically after fault condition is removed								
	OVER VOLTAGE	13.2 ~ 15.6V	16.5 ~ 19.5V	19.8 ~23.4V	26.4 ~ 31.2V	29.7 ~ 35.1V	39.6 ~ 46.8V	52.8 ~ 62.4V	56.7~59.4V	
	OVER TEMPERATURE	Protection type : Shut down o/p voltage, recovers automatically after temperature goes down								
FUNCTION	5V STANDBY	5Vsb : 5V@0.6A without fan, 1A with fan 25CFM ; tolerance ±2%, ripple : 120mVp-p(max.)								
	12V FAN SUPPLY	12V@0.5A for driving a fan ; tolerance -15% ~+10% at main output 20% rated current (25CFM)								
	PS-ON INPUT SIGNAL	Power on: PS-ON = "Hi" or " > 2 ~ 5V" ; Power off: PS-ON = "Low" or " < 0 ~ 0.5V"								
	POWER GOOD / POWER FAIL	500ms>PG>10ms ; The TTL signal goes high with 10ms to 500ms delay after power set up ; The TTL signal goes low at least 1ms before Vo below 90% of rated value								
ENVIRONMENT	WORKING TEMP.	-30 ~ +70°C (Refer to "Derating Curve")								
	WORKING HUMIDITY	20 ~ 90% RH non-condensing								
	STORAGE TEMP.	-40 ~ +85°C								
	TEMP. COEFFICIENT	±0.03%/°C (0 ~ 50°C)								
	VIBRATION	10 ~ 500Hz, 2G 10min./1cycle, 60min. each along X, Y, Z axes								
OPERATING ALTITUDE <small>Note.5</small>	5000 meters									



SPECIFICATION

SAFETY & EMC (Note 6)	SAFETY STANDARDS	UL62368-1, TUV BS EN/EN62368-1, BS EN/EN60335-1, IEC62368-1, EAC TP TC 004 approved										
	WITHSTAND VOLTAGE	I/P-O/P:3KVAC I/P-FG:2KVAC O/P-FG:0.5KVAC										
	ISOLATION RESISTANCE	I/P-O/P, I/P-FG:100M Ohms / 500VDC / 25°C / 70% RH										
	EMC EMISSION	Parameter	Standard	Test Level / Note								
		Conducted	BS EN/EN55032(CISPR32), CNS13438	Class I : Class B , Class II : Class A								
		Radiated	BS EN/EN55032(CISPR32), CNS13438	Class A								
		Harmonic Current	BS EN/EN61000-3-2	Class A								
		Voltage Flicker	BS EN/EN61000-3-3	-----								
	EMC IMMUNITY	BS EN/EN55024, BS EN/EN61000-6-2										
		Parameter	Standard	Test Level /Note								
ESD		BS EN/EN61000-4-2	Level 3, 8KV air; Level 2, 4KV contact, criteria A									
Radiated Susceptibility		BS EN/EN61000-4-3	Level 3, criteria A									
EFT/Burest		BS EN/EN61000-4-4	Level 3, criteria A									
Surge		BS EN/EN61000-4-5	Level 4,2KV/L-N, criteria A									
Conducted		BS EN/EN61000-4-6	Level 3, criteria A									
Magnetic Field		BS EN/EN61000-4-8	Level 4, criteria A									
	Voltage Dips and interruptions	BS EN/EN61000-4-11	>95% dip 0. 5 periods, 30% dip 25 periods, >95% interruptions 250 periods									
OTHERS	MTBF	1133.6K hrs min. Telcordia SR-332 (Bellcore) ; 137.1K hrs min. MIL-HDBK-217F (25°C)										
	DIMENSION	L*W*H	127x76.2x41mm									
			5"x3"x1.61"inch									
	PACKING	P.W.	0.46Kg									
		Q'TY	30pcs									
G.W.		14.8Kg										
M'MENT		0.96CUFT										
NOTE	<p>1. All parameters NOT specially mentioned are measured at 230VAC input, rated load and 25 of ambient temperature.</p> <p>2. Ripple & noise are measured at 20MHz of bandwidth by using a 12" twisted pair-wire terminated with a 0.1μF & 47μF parallel capacitor.</p> <p>3. Tolerance : includes set up tolerance, line regulation and load regulation.</p> <p>4. Derating may be needed under low input voltages. Please check the derating curve for more details.</p> <p>5. The ambient temperature derating of 3.5°C/1000m with fanless models and of 5°C/1000m with fan models for operating altitude higher than 2000m(6500ft).</p> <p>6. The power supply is considered a component which will be installed into a final equipment. All the Class I (with FG) EMC test are been executed by mounting the unit on a 360mm*360mm metal plate with 1mm of thickness. final equipment must be re-confirmed that it still meets EMC directives. For guidance on how to perform these EMC tests, please refer to "EMI testing of component power supplies." (as available on https://www.meanwell.com/Upload/PDF/EMI_statement_en.pdf)</p> <p>※ Product Liability Disclaimer : For detailed information, please refer to https://www.meanwell.com/serviceDisclaimer.aspx</p> <table border="1" style="margin-left: 20px;"> <tr> <td>EMI Performance</td> <td>Conducted</td> <td>Radiated</td> </tr> <tr> <td>Class I (with FG)</td> <td>Class B</td> <td>Class A</td> </tr> <tr> <td>Class II (no FG)</td> <td>Class A</td> <td>Class A</td> </tr> </table>			EMI Performance	Conducted	Radiated	Class I (with FG)	Class B	Class A	Class II (no FG)	Class A	Class A
EMI Performance	Conducted	Radiated										
Class I (with FG)	Class B	Class A										
Class II (no FG)	Class A	Class A										

Block Diagram

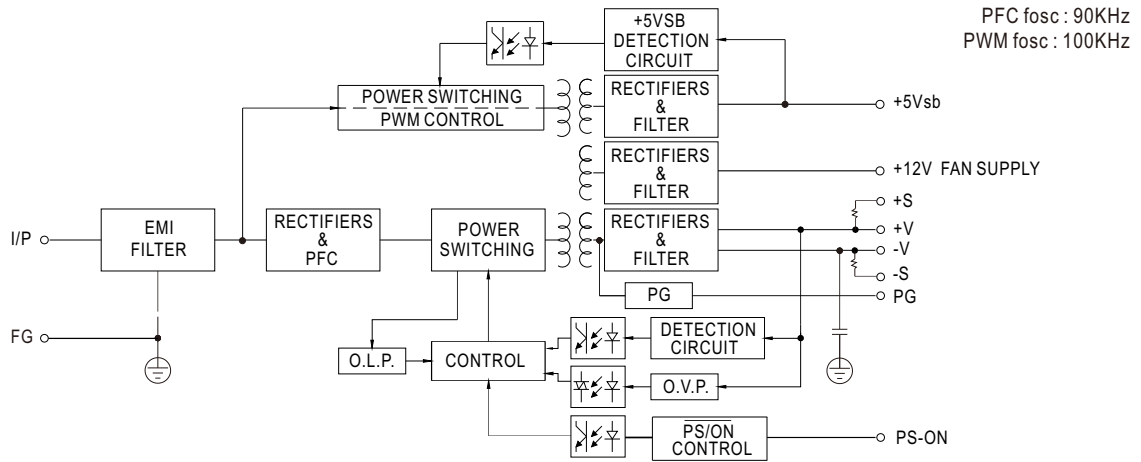

Derating Curve

Output Derating VS Input Voltage

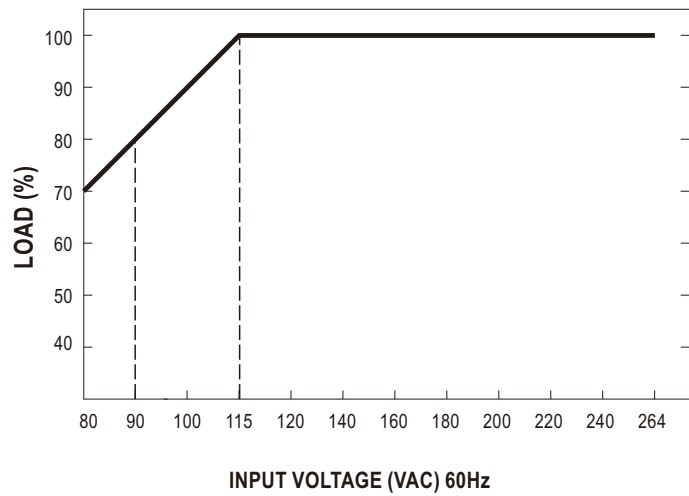
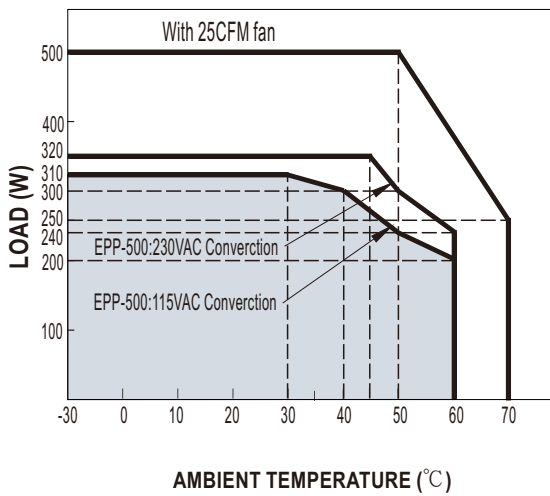

Convection	320W/230Vac 310W/115Vac
Force Air	500W

Mechanical Specification

(Unit: mm , tolerance ± 1mm)

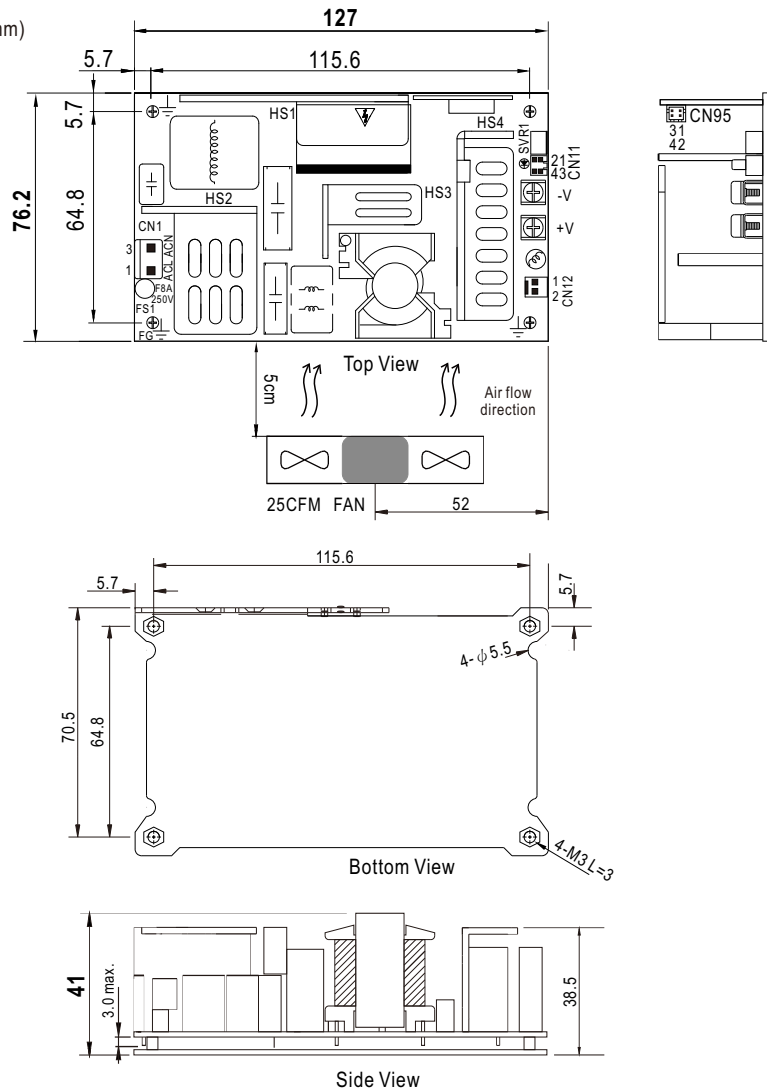

CONNECTION

AC Input Connector (CN1) : JST B3P-VH or equivalent

Pin No.	Assignment	Mating Housing	Terminal
1	AC/L	JST VHR or equivalent	JST SVH-21T-P1.1 or equivalent
2	No Pin		
3	AC/N		

Function Connector(CN11): TKP DH2L-2X2 or equivalent

Pin No.	Assignment	Mating Housing	Terminal
1	-S	TKP DH2 or equivalent	TKP or equivalent
2	+S		
3	DC COM		
4	PG		

DC Output Connector (CN2,CN3)

Pin No.	Assignment	Output Terminals
CN2	-V	M3.5 Pan HD screw in 2 positions Torque to 8 lbs-in(90cNm)max.
CN3	+V	

Function Connector(CN95): TKP DH2L-2X2 or equivalent

Pin No.	Assignment	Mating Housing	Terminal
1	5Vsb	TKP DH2 or equivalent	TKP or equivalent
2,4	DC COM		
3	PS-ON		

! HS1,HS2,HS3,HS4 can not be shorted

FAN Connector(CN12) : TKP 8812-2 or equivalent
(Except for RPS-500-TF/SF)

Pin No.	Assignment	Mating Housing	Terminal
1	DC COM	TKP 2502 or equivalent	TKP 8811 or equivalent
2	+12V		

Installation Manual

Please refer to : <http://www.meanwell.com/manual.html>