

## ■ Features

## ■ Applications

- 5"×3" miniature size
- Universal AC input / Full range
- Built-in active PFC function
- EMI Class B for Class I & Class A for Class II configuration
- No load power consumption<0.5W by PS\_ON control
- High efficiency up to 94%
- Protections: Short circuit / Overload / Over voltage / Over temperature
- Cooling by free air convection for 250W and 400W with 25CFM forced air
- Built-in 12V/0.5A FAN supply
- Standby 5V@1A with fan , 0.6A without fan
- Built-in remote sense function
- LED indicator for power on
- Output 18V available
- Operating altitude up to 5000 meters
- 3 years warranty

- Industrial automation machinery
- Industrial control system
- Mechanical and electrical equipment
- Electronic instruments, equipments or apparatus

## ■ GTIN CODE

MW Search : <https://www.meanwell.com/serviceGTIN.aspx>

## ■ Description

EPP-400 is a 400W highly reliable green PCB type power supply with a high power density on the 5" by 3" footprint. It accepts 80~264VAC input and offers various output voltages between 12V and 48V. The working efficiency is up to 94% and the extremely low no load power consumption is down below 0.5W. EPP-400 is able to be used for both Class I (with FG) and Class II (no FG) system design. EPP-400 is equipped with complete protection functions; it is complied with the international safety regulations such as TUV BS EN/EN62368-1, TUV BS EN/EN60335-1, UL62368-1 and IEC62368-1. EPP-400 series serves as a high price-to-performance power supply solution for various industrial applications.

## ■ Model Encoding

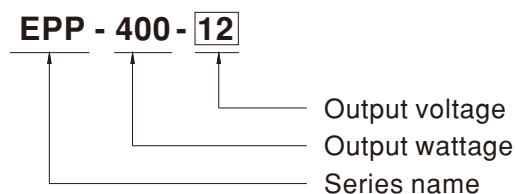

**SPECIFICATION**

MODEL		EPP-400-12	EPP-400-15	EPP-400-18	EPP-400-24	EPP-400-27	EPP-400-36	EPP-400-48	
OUTPUT	DC VOLTAGE	12V	15V	18V	24V	27V	36V	48V	
	CURRENT	25CFM	33.3A	26.7A	22.3A	16.7A	14.9A	11.2A	8.4A
		Convection	20.8A	16.7A	13.9A	10.5A	9.3A	7A	5.3A
	RATED POWER	25CFM	399.6W	400.5W	401.4W	400.8W	402.3W	403.2W	403.2W
		Convection	249.6W	250.5W	250.5W	252W	251.1W	252W	254.4W
	RIPPLE & NOISE (max.) Note.2	120mVp-p	150mVp-p	180mVp-p	200mVp-p	200mVp-p	250mVp-p	250mVp-p	
	VOLTAGE ADJ. RANGE(MAIN OUTPUT)	11.4~12.6V	14.3~15.8V	17.1~18.9V	22.8~25.2V	25.6 ~ 28.4V	34.2 ~37.8V	45.6 ~50.4V	
	VOLTAGE TOLERANCE Note.3	±3.0%	±3.0%	±3.0%	±2.0%	±1.0%	±1.0%	±1.0%	
	LINE REGULATION	±0.5%	±0.5%	±0.5%	±0.5%	±0.5%	±0.5%	±0.5%	
	LOAD REGULATION	±1.0%	±1.0%	±1.0%	±1.0%	±1.0%	±1.0%	±1.0%	
SETUP, RISE TIME	1000ms, 30ms/230VAC    1500ms, 30ms/115VAC at full load								
HOLD UP TIME (Typ.)	16ms/230VAC    12ms/115VAC at full load								
INPUT	VOLTAGE RANGE Note.4	80 ~ 264VAC    113 ~ 370VDC							
	FREQUENCY RANGE	47 ~ 63Hz							
	POWER FACTOR	PF>0.94/230VAC PF>0.98/115VAC at full load							
	EFFICIENCY (Typ.)	91.5%	92%	93%	93%	93.5%	93%	94%	
	AC CURRENT (Typ.)	4.2A/115VAC    2.1A/230VAC							
	INRUSH CURRENT (Typ.)	COLD START 40A/115VAC		80A/230VAC					
	LEAKAGE CURRENT	<0.75mA / 240VAC							
PROTECTION	OVERLOAD	105 ~ 135% rated output power Protection type : Hiccup mode, recovers automatically after fault condition is removed							
	OVER VOLTAGE	13.2 ~ 15.6V	16.5 ~ 19.5V	19.8 ~ 23.4V	26.4 ~ 31.2V	29.7 ~ 35.1V	39.6 ~ 46.8V	52.8 ~ 62.4V	
	OVER TEMPERATURE	Protection type : Shut down o/p voltage, recovers automatically after temperature goes down							
FUNCTION	5V STANDBY	5VSB : 5V@0.6A without fan, 1A with fan 25CFM ; tolerance ±2%, ripple : 120mVp-p(max.)							
	FAN SUPPLY	12V@0.5A for driving a fan ; tolerance -15% ~+10% at main output 35% rated current (25CFM)							
	PS-ON INPUT SIGNAL	Power on: PS-ON = "Hi" or " > 2 ~ 5V" ; Power off: PS-ON = "Low" or " < 0 ~ 0.5V"							
	POWER GOOD / POWER FAIL	500ms>PG>10ms ; The TTL signal goes high with 10ms to 500ms delay after power set up ; The TTL signal goes low at least 1ms before Vo below 90% of rated value							
ENVIRONMENT	WORKING TEMP.	-30 ~ +70°C (Refer to "Derating Curve")							
	WORKING HUMIDITY	20 ~ 90% RH non-condensing							
	STORAGE TEMP., HUMIDITY	-40 ~ +85°C, 10 ~ 95% RH							
	TEMP. COEFFICIENT	±0.03%/°C (0 ~ 50°C)							
	OPERATING ALTITUDE Note.7	5000 meters							
	VIBRATION	10 ~ 500Hz, 2G 10min./1cycle, 60min. each along X, Y, Z axes							
SAFETY & EMC (Note 5)	SAFETY STANDARDS	UL62368-1, TUV BS EN/EN62368-1, BS EN/EN60335-1, IEC62368-1, CCC GB4943.1, EAC TP TC 004 approved							
	WITHSTAND VOLTAGE	I/P-O/P:3KVAC    I/P-FG:2KVAC    O/P-FG:0.5KVAC							
	ISOLATION RESISTANCE	I/P-O/P, I/P-FG:100M Ohms / 500VDC / 25°C/ 70% RH							
	EMC EMISSION	Compliance to BS EN/EN55032 (CISPR32) Class B, BS EN/EN61000-3-2,-3, CCC GB17625.1, GB/T9254, EAC TP TC 020							
	EMC IMMUNITY	Compliance to BS EN/EN61000-4-2,3,4,5,6,8,11, BS EN/EN55035, BS EN/EN61000-6-2, heavy industry level, EAC TP TC 020							
OTHERS	MTBF	1395.2K hrs min.    Telcordia SR-332 (Bellcore) ; 194.1K hrs min.    MIL-HDBK-217F (25°C)							
	DIMENSION	127*76.2*35mm (L*W*H)							
	PACKING	0.39Kg; 36pcs/15Kg/0.96CUFT							
NOTE	<p>1. All parameters NOT specially mentioned are measured at 230VAC input, rated load and 25 of ambient temperature.</p> <p>2. Ripple &amp; noise are measured at 20MHz of bandwidth by using a 12" twisted pair-wire terminated with a 0.1 μ F &amp; 47 μ F parallel capacitor.</p> <p>3. Tolerance : includes set up tolerance, line regulation and load regulation.</p> <p>4. Derating may be needed under low input voltages. Please check the derating curve for more details.</p> <p>5. Touch current was measured from primary input to DC output.</p> <p>6. The power supply is considered a component which will be installed into a final equipment. All the Class I (with FG) EMC test are been executed by mounting the unit on a 360mm*360mm metal plate with 1mm of thickness. The Class II (without FG) EMC test is been executed by mounting the unit on a 130mm*86.6mm metal plate with 1mm of thickness. final equipment must be re-confirmed that it still meets EMC directives. For guidance on how to perform these EMC tests, please refer to "EMI testing of component power supplies." (as available on <a href="https://www.meanwell.com/Upload/PDF/EMI_statement_en.pdf">https://www.meanwell.com/Upload/PDF/EMI_statement_en.pdf</a> )</p> <p>7. The ambient temperature derating of 3.5°C/1000m with fanless models and of 5°C/1000m with fan models for operating altitude higher than 2000m(6500ft).</p> <p>※ Product Liability Disclaimer : For detailed information, please refer to <a href="https://www.meanwell.com/serviceDisclaimer.aspx">https://www.meanwell.com/serviceDisclaimer.aspx</a></p>								

■ Block Diagram

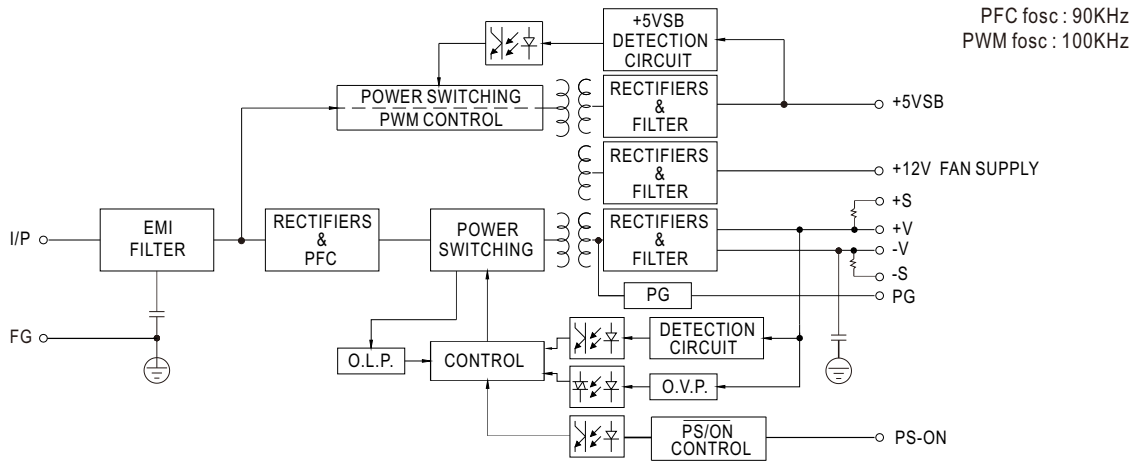

■ Derating Curve

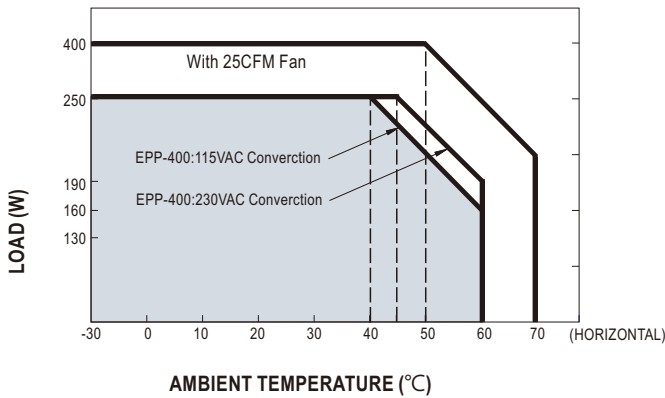

■ Output Derating VS Input Voltage

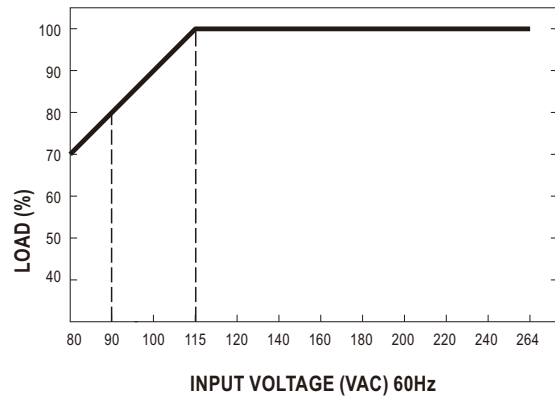

Without Fan Watt	250W
With Fan Watt	400W

**Mechanical Specification**

(Unit: mm , tolerance ± 1mm)

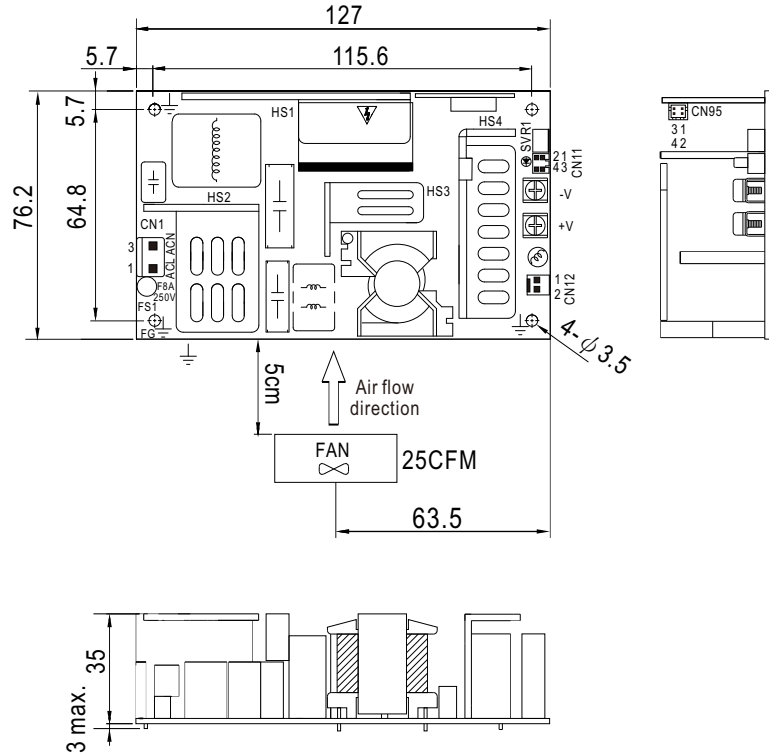

AC Input Connector (CN1) : JST B3P-VH or equivalent

Pin No.	Assignment	Mating Housing	Terminal
1	AC/L	JST VHR or equivalent	JST SVH-21T-P1.1 or equivalent
2	No Pin		
3	AC/N		

DC Output Connector (CN2,CN3)

Pin No.	Assignment	Output Terminals
CN2	-V	M3.5 Pan HD screw in 2 positions Torque to 8 lbs-in(90cNm)max.
CN3	+V	

Function Connector(CN95): TKP DH2L-2X2 or equivalent

Pin No.	Assignment	Mating Housing	Terminal
1	5VSB	TKP DH2 or equivalent	TKP or equivalent
2,4	DC COM		
3	PS-ON		

Function Connector(CN11): TKP DH2I-2X2 or equivalent

Pin No.	Assignment	Mating Housing	Terminal
1	-S	TKP DH2 or equivalent	TKP or equivalent
2	+S		
3	DC COM		
4	PG		

FAN Connector(CN12) : TKP 8812-2 or equivalent

Pin No.	Assignment	Mating Housing	Terminal
1	DC COM	TKP 2502 or equivalent	TKP 8811 or equivalent
2	+12V		

⊥ Grounding Required

⚠ HS1,HS2,HS3,HS4 can not be shorted

⊗ Note: When the input voltage is AC 230V the model delivers EMI Class B for both conducted emission and radiated emission for the power supply. When the input voltage is AC110V the model delivers EMI Class B for conducted emission ,Class A for radiated emission for the power supply.  
It delivers Class A for conduced emission and radiated emission, when configured into Class II (without FG) system.

**Installation Manual**

Please refer to : <http://www.meanwell.com/webnet/search/InstallationSearch.html>