

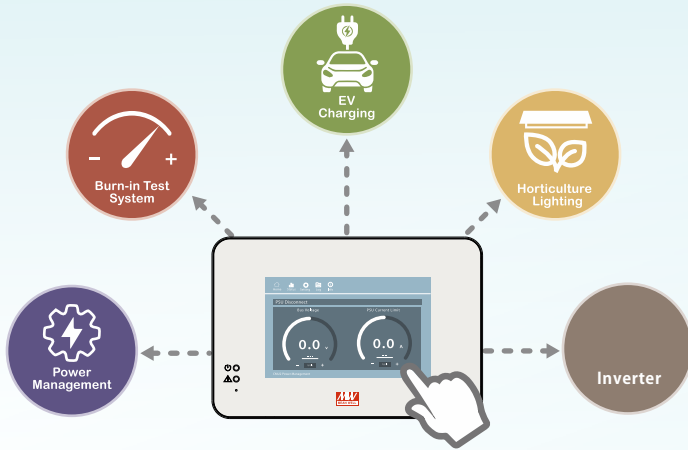

# CMU2E User's Manual



*Multi-Industry General Purpose Smart Controller*

• Programmable • Intelligent • Smart UI

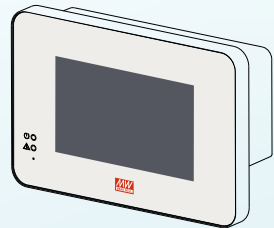
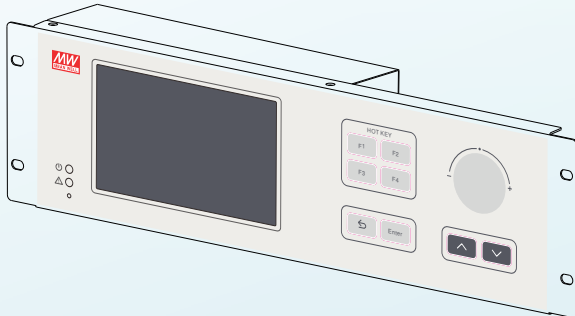

CMU2E is a fully digital graphical user interface (GUI) controller, capable of executing monitoring and control tasks for MEANWELL's inverter systems. With its intuitive 7-inch TFT LCD touchscreen panel and physical buttons, users can easily perform on-site operations. The Ethernet port enables expanded connectivity, allowing for direct local-to-remote data access and real time monitoring and control of the system. Equipped with four sets of programmable relays and five sets of isolated digital output signals, the CMU2E offers flexibility in monitoring specific events or alarms for users. Additionally, the CMU2E supports data and event logging with date and time stamps, ensuring comprehensive record-keeping for analysis and troubleshooting.

# Contents

<b>1.Safety Guidelines</b>	1	<b>6.Maintenance</b>	87
1.1 Passwords	1	6.1 Firmware update instruction	87
<b>2.Introduction</b>	2	<b>7.Warranty</b>	90
2.1 Model Encoding	2		
2.2 Features	2		
2.3 Specification	3		
2.4 Mechanical Specification	4		
2.5 Supported Models	7		
<b>3.Installation &amp; Wiring</b>	7		
3.1 Installation	7		
3.2 Configuration	9		
3.3 SD Card Installation	10		
<b>4.User Interface</b>	14		
4.1 Panel Description	14		
4.2 LED indication	15		
4.3 Pin assignment of DOUT	16		
4.4 Pin assignment of DIN	17		
4.5 Pin assignment of AC INPUT	18		
4.6 Pin assignment of RELAY	19		
4.7 Pin assignment of PMBus	20		
(not supported)			
4.8 Pin assignment of CANBus	21		
(not supported)			
4.9 Pin assignment of Ethernet	22		
4.10 Pin assignment of RS-485	23		
<b>5.Operation</b>	24		
5.1 Touch panel	24		
5.2 Web-based User Interface	50		
5.3 Modbus TCP Interface	68		

# 1.Safety Guidelines

- Risk of electrical shock and energy hazard, all failure should be examined by a qualified technician. Please do not remove the case from the controller by yourself.
- Please do not install the controller in places with high moisture, high ambient temperature or under direct sunlight.
- The AC voltage range is 85 – 265Vac (47 – 63Hz), please do not connect the unit to AC grid out of the range.
- The safety protection level of this controller is class I. The “Frame Ground” (≡) of the unit must be well connected to PE (Protective Earth).
- Do not use sharp objects or tools in the vicinity of the LCD touch panel.
- Treat the LCD carefully to prevent puncture, bursting, or cracking of the screen.
- If the LCD is damaged and any liquid comes in contact with your skin, immediately rinse the area with running water for at least 15 minutes. If the liquid gets in your eyes, immediately rinse your eyes with running water for at least 15 minutes and consult a doctor.

## 1.1 Passwords

Password is required to edit network settings. The following is the default password for the interfaces:

Touch panel interface: The password is entered when selecting System in Setting page.

- By default, the password is “CMU2E” .

# 2.Introduction

## 2.1 Model Encoding

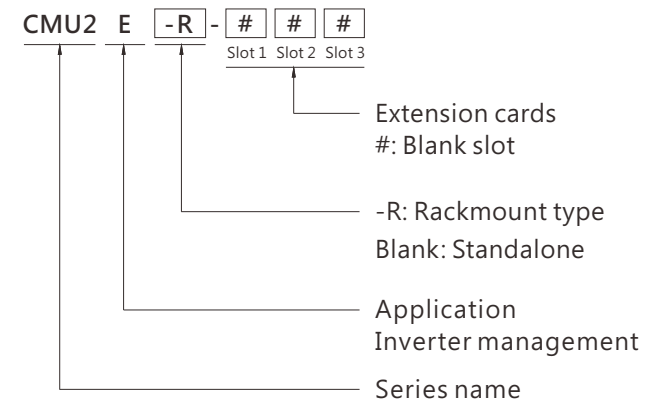

## 2.2 Features

- Integration on system power
- Models in 3U 19-inch rack-mount and standalone configurations
- 7 panel and buttons for easy operation on-site “ touch operation
- Ethernet port for on-site or remote monitor and control over the system
- Modbus communication protocol
- Support Data/ Event log with date and time (Note.1)
- Support max. 32G SDHC SD card
- Four user programmable relay outputs for conventional remote monitoring or warning
- Web-based monitor/control UI provided for various applications
- 5 years warranty

## 2.3 Specification

MODEL (Note.9)		CMU2E	CMU2E-R
OUTPUT	LCD DISPLAY	Display the DC output voltage, current, and status of each PSU	
	LED INDICATOR	Green: Power on/ Normal Red: Fault/ Abnormal	
	RELAY CONTACT	Note.5	4 user programmable channels, 30V/1A
	ANALOG OUTPUT	Note.5	5 user programmable channels, 0-10V
	DIGITAL OUTPUT	Note.5	5 user programmable channels, open collector signal
INPUT	VOLTAGE RANGE	85 ~ 264VAC; 120-370VDC	
	FREQUENCY RANGE	47 ~ 63Hz	
	CURRENT	0.6A / 115VAC	0.4A / 230VAC
	ANALOG INPUT	Note.5	5 Channels, 0-10V, 12bit resolution
	DIGITAL INPUT	Note.5	5 Channels, open collector signal
FUNCTION	MONITORED	I/P & O/P Voltage, O/P current, temperature, fan rpm	
	COMM. INTERFACE	Note.2	PMBus, CANbus
	SD CARD SLOT	SDHC 32GB Max.	
	FIRMWARE UPDATE	Update can be done via SD card or Ethernet access	
	UI LANGUAGE	English, Traditional/Simplified Chinese	
	LOG	Record data and events	
	BUZZER	Alarms, mute Button click & alarms, mute	
COMMUNICATION PROTOCOLS	PMBUS	Note.5	PMBus v1.1
	CANBUS	Note.5	CANbus 2.0B
	NETWORK	Support IEEE802.3, 10/100base network	
	EXTENSION CARDS	Note.2	Extension Cards
ETHERNET SUPPORTED	PROTOCOLS	TCP/IP, NTP, SMTP, Modbus TCP	
	WEB SERVER	Display status of system, parameters, data being logged or download	
EXTENSION CARDS	PMBUS	Note.8	2 PMBus ports, PMBus V1.1
	CANBUS	Note.8	2 CANBus ports, CANBus 2.0B
	USB/RS-232/RS-485	2 USB ports, RS-232 port, RS-485 port	
DISPLAY	LCD PANEL	Note.3	7" TFT LCD, resolution 800x480, capacitive touch panel Details of settings please refer to user's manual
	WORKING TEMP.	Note.3	-25 ~ +60°C
ENVIRONMENT	STORAGE TEMP.	-40 ~ +60°C	
	VIBRATION	10 ~ 500Hz, 2G 10min./1cycle, 60min. each along X, Y, Z axes	
	SAFETY STANDARDS	IEC62368-1, BS EN/EN62368-1 approved	
SAFETY & EMC (Note 6)	WITHSTAND VOLTAGE	Note.4	I/P-O/P:3KVAC I/P-FG:2KVAC O/P-FG:0.7KVDC
	ISOLATION RESISTANCE	Note.4	O/P-FG:100M Ohms / 500VDC / 25°C / 70% RH
	EMC EMISSION	Compliance to BS EN/EN55032 (CISPR32) Conduction Class B, Radiation Class A ; BS EN/EN61000-3-2,-3	
	EMC IMMUNITY	Compliance to BS EN/EN61000-4-2,3,4,5,6,8,11, BS EN/EN61000-6-1(BS EN/EN50082-2), light industry level, criteria A	
OTHER	MTBF	680K hrs min. Telcordia TR/SR-332 (Bellcore) ; 75.9K hrs min. MIL-HDBK-217F (25°C)(-C) 690.3K hrs min. Telcordia TR/SR-332 (Bellcore) ; 78.9K hrs min. MIL-HDBK-217F (25°C)(-E)	
	DIMENSION	245*70*164.2mm (L*W*H) 483.6*66.3*132mm (L*W*H)	
	PACKING	1.68Kg; 8pcs/14.4Kg/2.14CUFT 2.16Kg; 6pcs/14Kg/2.91CUFT	
NOTE	1.Data log and event log functions are only available when an SD card is installed. 2.Depend on application. 3.LCD may freeze under -20°C. 4.CN36,CN37 are considered as O/P. 5.All functions of signal connectors: DIN/DOUT,AIN/AOUT,Relay,RS-232,RS-485,PMBus,CANBus are defined by application. Please check installation manual for detail. 6.The controller is considered a component which will be installed into a final equipment. EMC is tested by the controller unit, no control equipment is connected. The final equipment must re-confirmed that still meets EMC directives. For guidance on how to perform these EMC test, Please refer to "EMI testing of component power supplies"(as available on <a href="https://www.meanwell.com/Upload/PDF/EMI_statement_en.pdf">https://www.meanwell.com/Upload/PDF/EMI_statement_en.pdf</a> ) 7.The RTC power supply used super capacitors, which can last for only 7 days. If the time exceeds the limit, the RTC date must be re-adjusted. 8.Up to 40 power supplies can be operate in parallel connection, and possible up to 48 power supplies. 9.Order model only CMU2C-P##, CMU2C-R-P##, CMU2C-C##, CMU2C-R-C## and optional CMU2A-#R# available. ※ Product Liability Disclaimer : For detailed information, please refer to <a href="http://www.meanwell.com.cn/serviceDisclaimer.aspx">http://www.meanwell.com.cn/serviceDisclaimer.aspx</a>		

## 2.4 Mechanical Specification

### Standalone type

Unit:mm

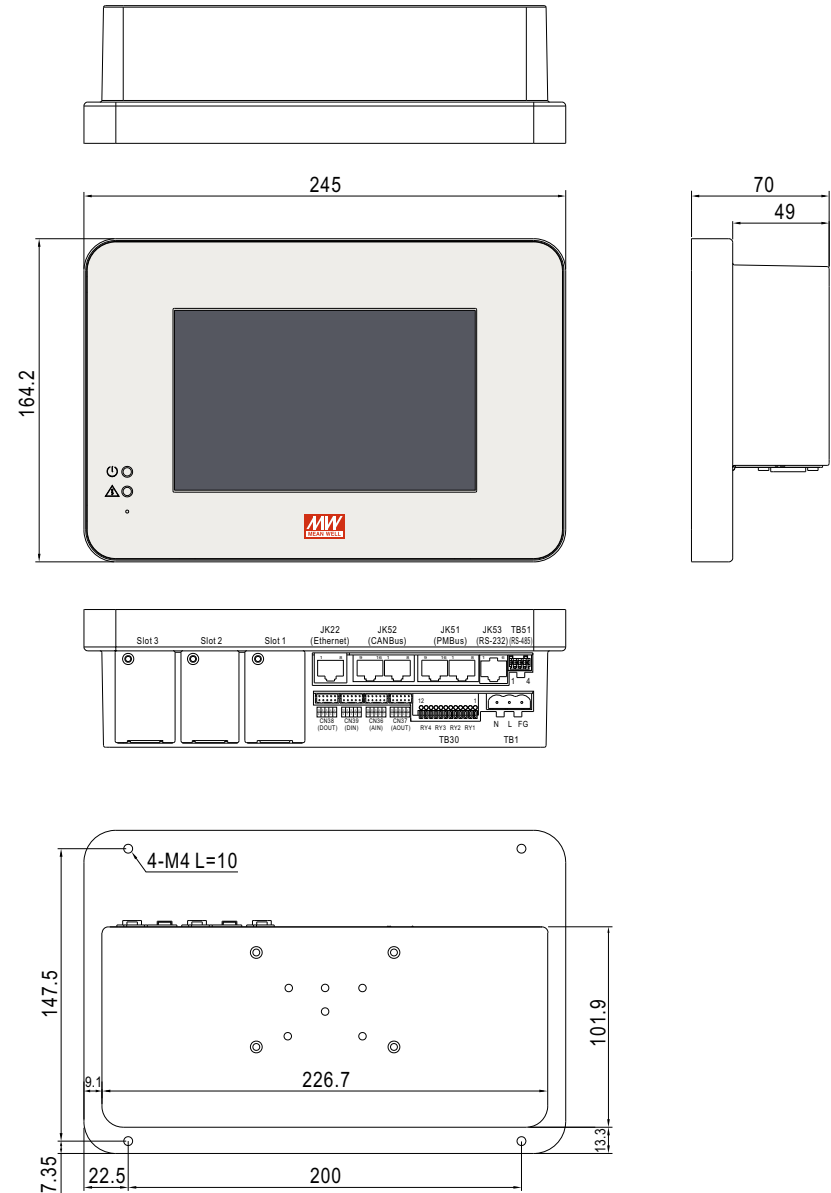

## Rack-mount typ

Unit:mm

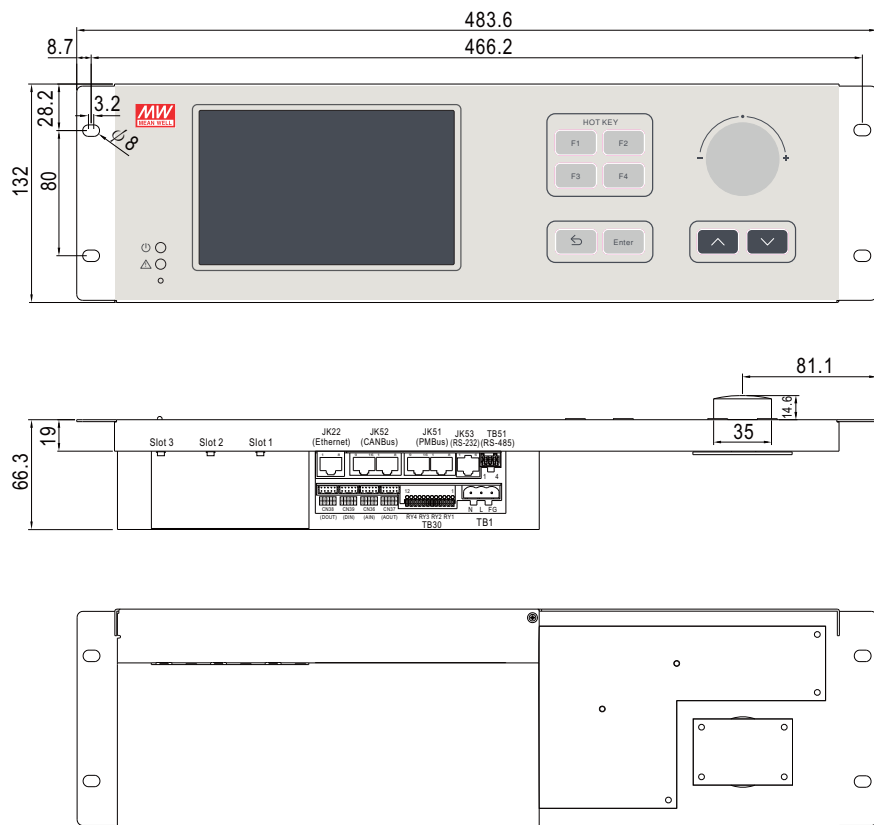

## Accessory (Standalone type only)

①	1GG2DRP14A	
②	1GG2MHS094	

Note: 1GG2DRP14A is suitable for installation on TS35/7.5 or TS35/15 rail

## 2.5 Supported Models

Model	Supported series
CMU2E-### CMU2E-R-###	NTN-5K

## 3. Installation & Wiring

### 3.1 Installation

#### 3.1.1 Standalone Type

##### 3.1.1.1 Wall Mounting

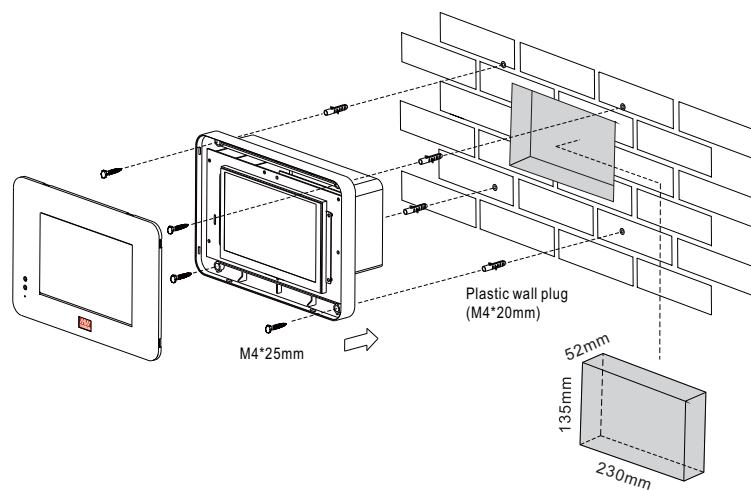

##### 3.1.1.2 Accessory Installation Din Rail

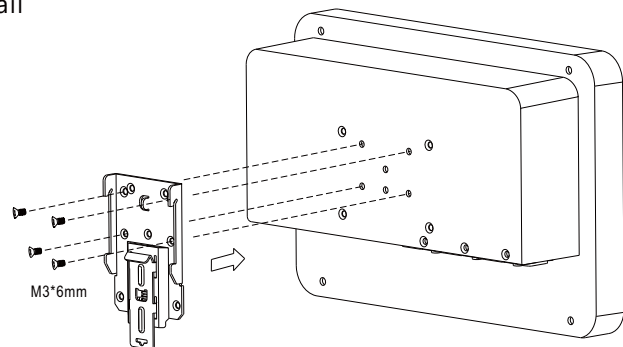

### Desktop

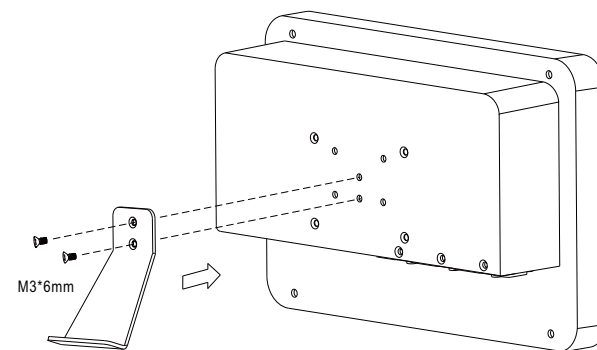

##### 3.1.2 Rack-mount type

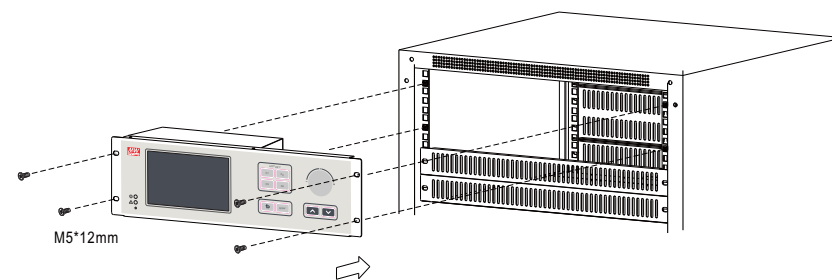

### 3.2 Configuration

The CMU2E is able to recognize up to 32 device addresses. Before connecting MEANWELL inverters to the communication port of the CMU2E, please make sure that these units have their unique and own device address to prevent communication issues caused by duplicate addressing. Location of the port is illustrated below.

Modbus port

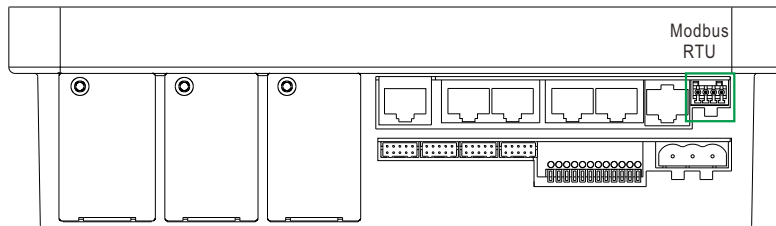

### 3.3 SD Card Installation

CMU2 supports SDHC type SD cards with capacity of 4G - 32G

#### Standalone type

- ① Before installing a SD card, please remove the top cover of the standalone version, the top cover is locked by 8 clips.

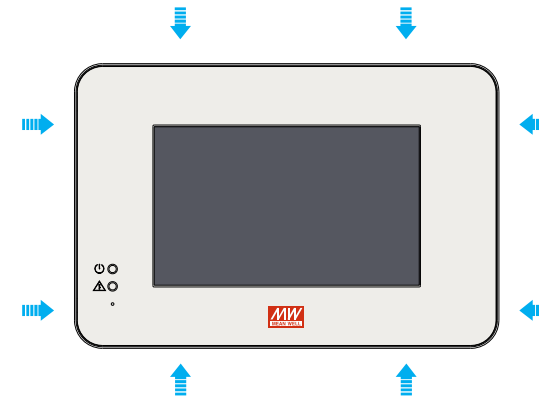

- ② The 8 clips can be released with a flat-blade screwdriver. After inserting the flat-head screwdriver into the gap between the top cover and the body, apply a little force to unlock the clips.

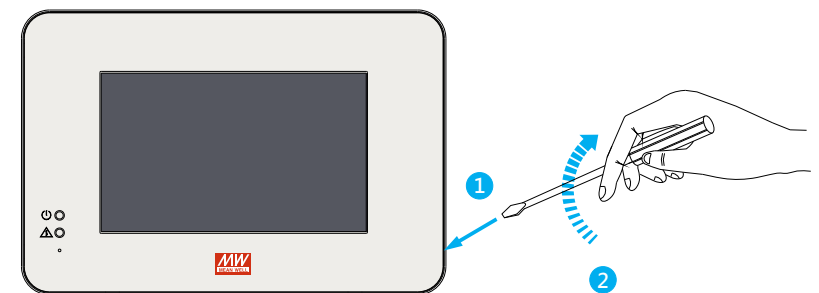

③ After the top cover is removed, please follow the steps below to insert a SD card. After a SD card is inserted, please reinstall the cover.

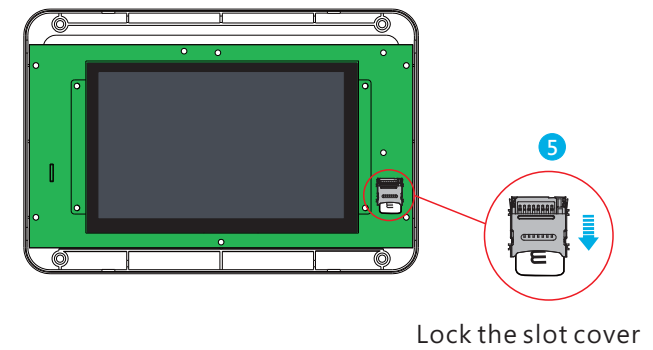
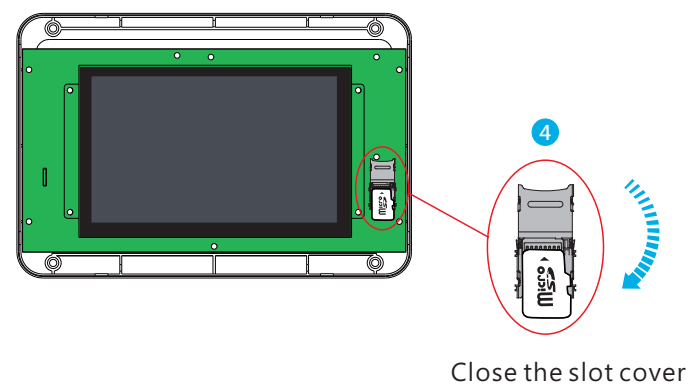
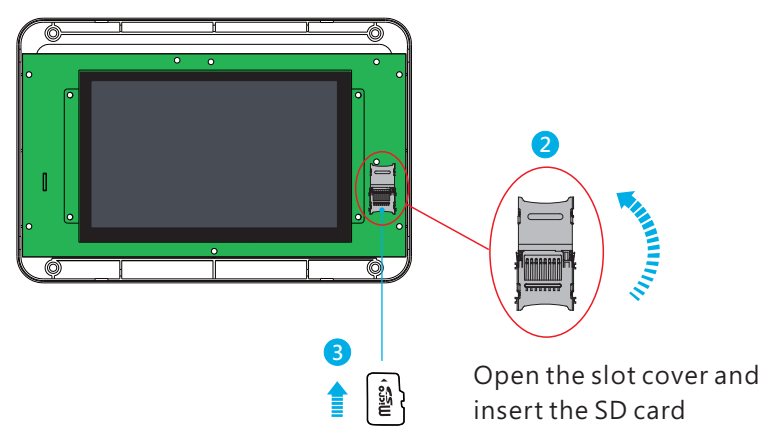
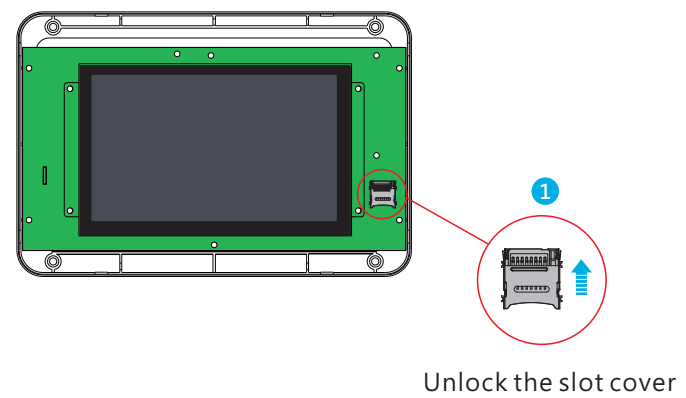

Rack-mount type

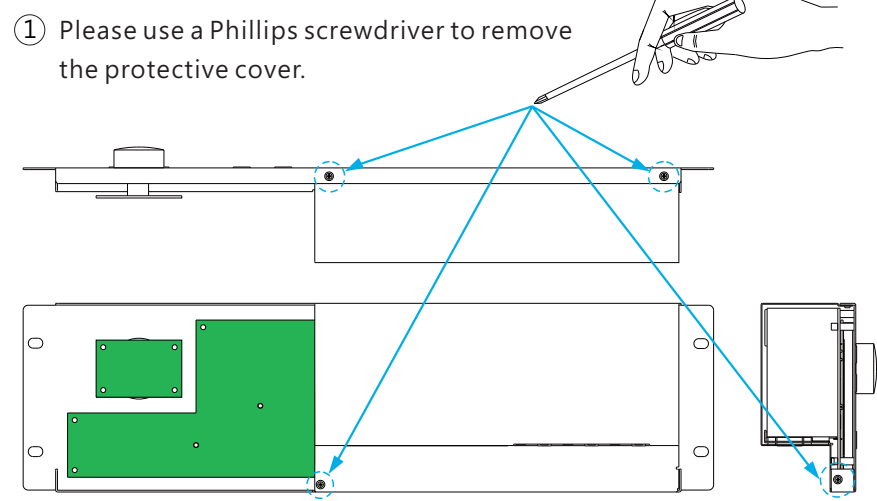

② After the cover is removed, please follow the steps below to insert a SD card. After a SD card is inserted, please reinstall the cover.

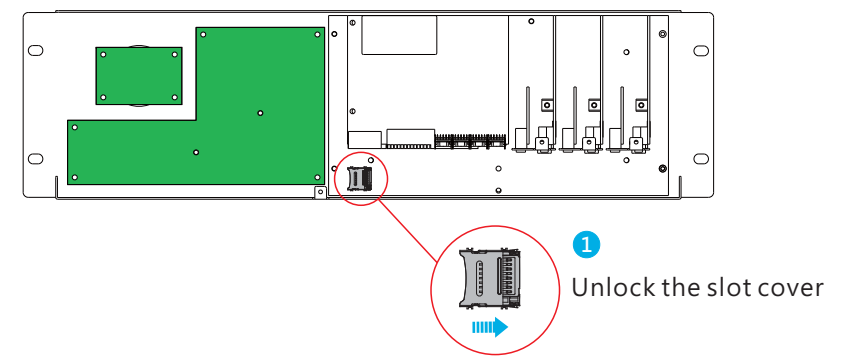

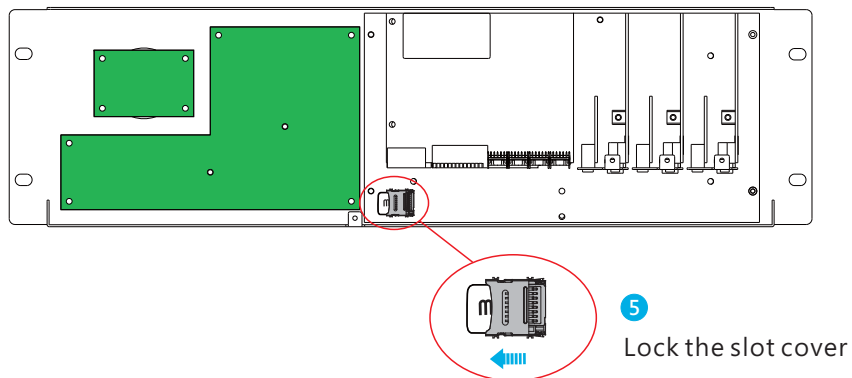
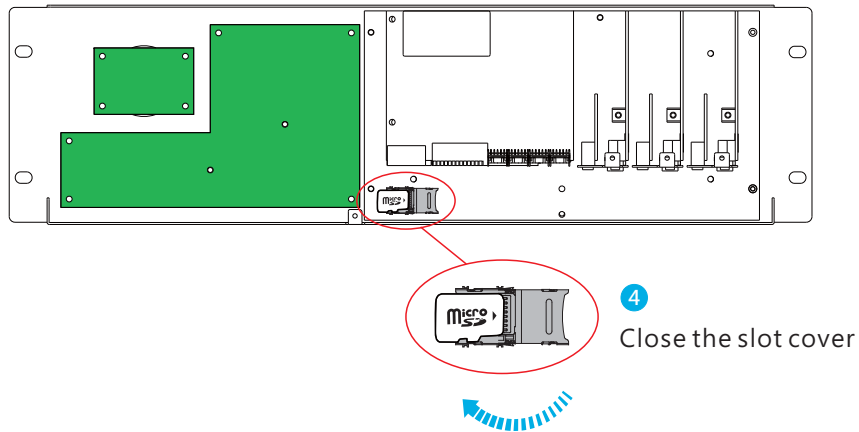
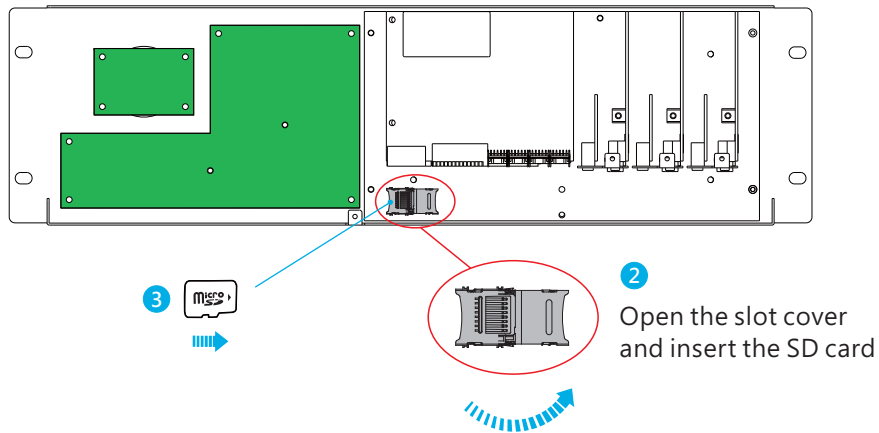

## 4. User Interface

### 4.1 Panel Description

- Ⓐ **Power indicator:**  
Used to display whether the CMU is powered on.
- Ⓑ **Alarm indicator:**  
Used to display operation status of the CMU2E
- Ⓒ **Touch panel:**  
Tap to select functional pages.
- Ⓓ **Hotkey buttons:**  
Press F1~F4 to enter the specific pages. F1: Home page; F2: event log page; F3: INV page; F4: Inverter mode page.
- Ⓔ **Knob:**  
It is used to adjust values for the selected charge parameter, increasing the value clockwise and decreasing it counter-clockwise. If the current page is not on the charger mode page, it will automatically switch to that page and default the value to the CC parameter.
- Ⓕ **Up and down buttons:**  
The up and down buttons are used to select charge parameters on the charger mode page, including CC, TC, CV and FV parameters.
- Ⓖ **Enter and return buttons:**  
On the charger mode page, the enter button can be used to apply a value that is adjusted by the Knob or use the return button to jump back to the home page.
- Ⓗ **Reset button:**  
Press to reset the CMU2E.

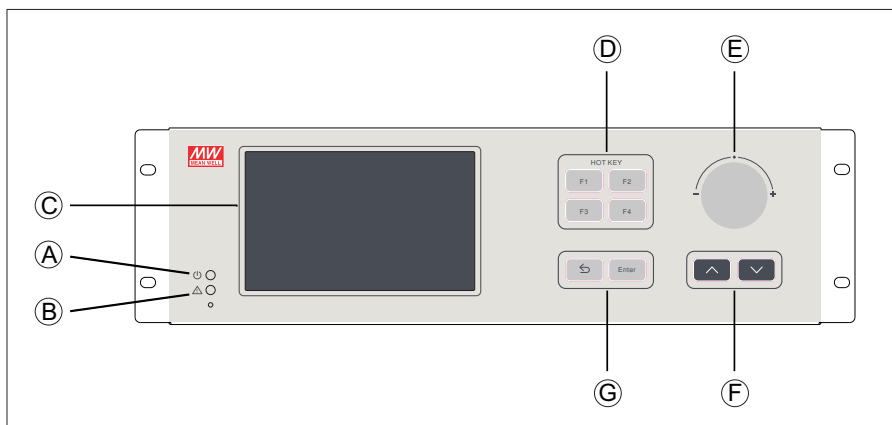
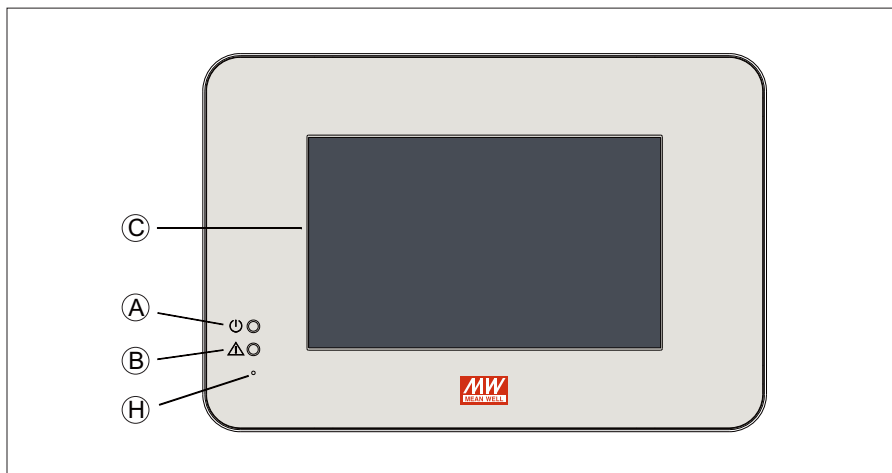

## 4.2 LED indication

LED	Status	Description
	Green	Power indication, constant green when power on.
	Red (flashing)	CMU2E or Rack Power in abnormal conditions.
	No indication	Normal working.

## 4.3 Pin assignment of DOUT

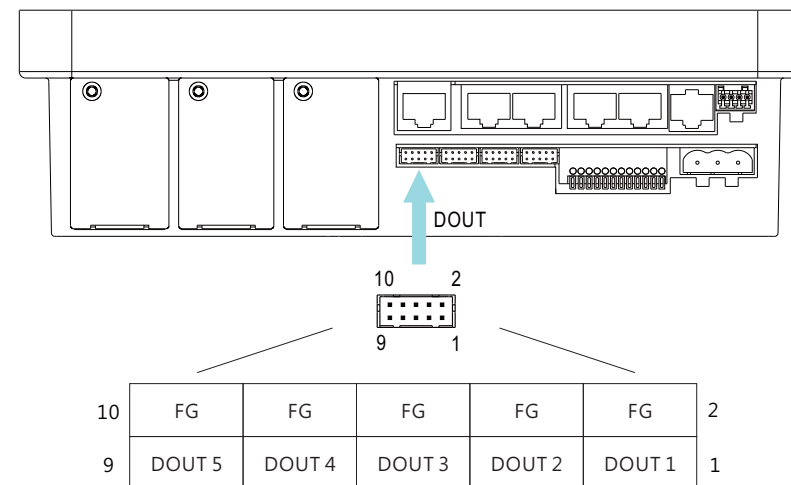

Pin No.	Function	Description
1	DOUT 1	The isolated digital output signal with FG as reference Open collector signal, Max. signal voltage is 5V with FG as reference
2,4,6,8,10	FG	Common FG for DOUTx
3	DOUT 2	The isolated digital output signal with FG as reference Open collector signal, Max. signal voltage is 5V with FG as reference
5	DOUT 3	
7	DOUT 4	
9	DOUT 5	

#### 4.4 Pin assignment of DIN

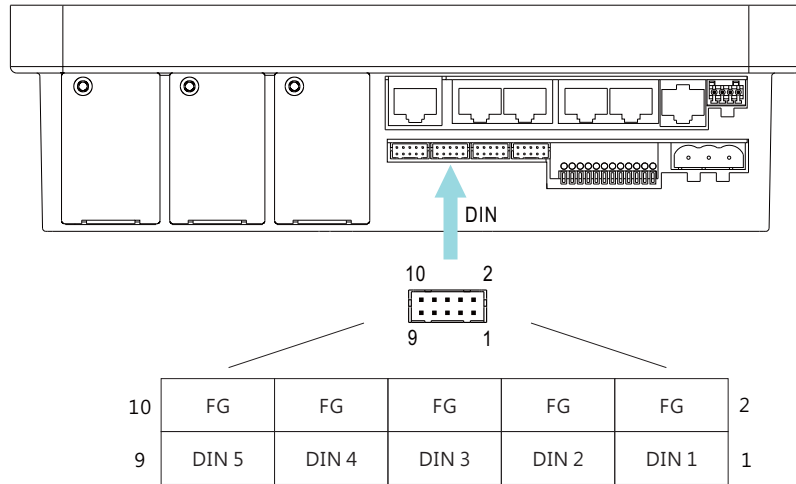

Pin No.	Function	Description
1	DIN 1	The isolated digital input signal with FG as reference Open collector signal Open from F4 or +5V: Logic "1" input to CMU2E Short to FG or 0V: Logic "0" input to CMU2E
2,4,6,8,10	FG	Common FG for DINx
3	DIN 2	The isolated digital input signal with FG as reference Open collector signal, Max. singal voltage is 5V with FG as reference
5	DIN 3	
7	DIN 4	
9	DIN 5	

#### 4.5 Pin assignment of AC INPUT

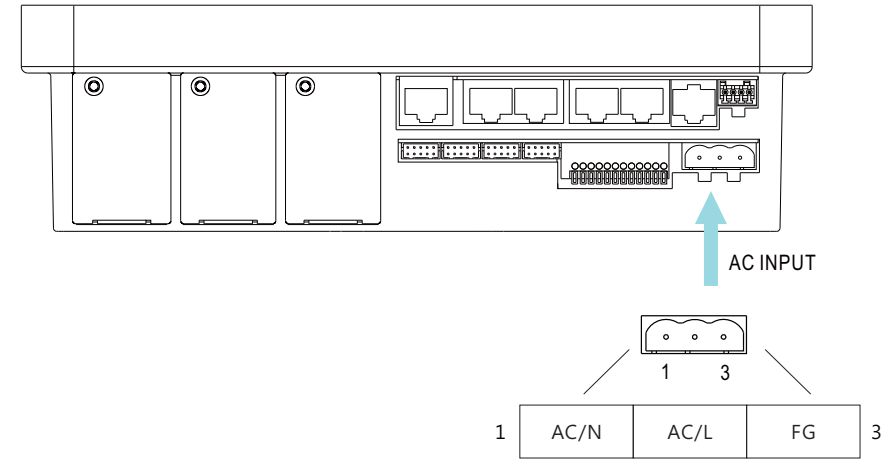

Pin No.	Function	Description
1	AC/N	AC input neutral wire
2	AC/L	AC input live wire
3	FG	FG wire

## 4.6 Pin assignment of RELAY

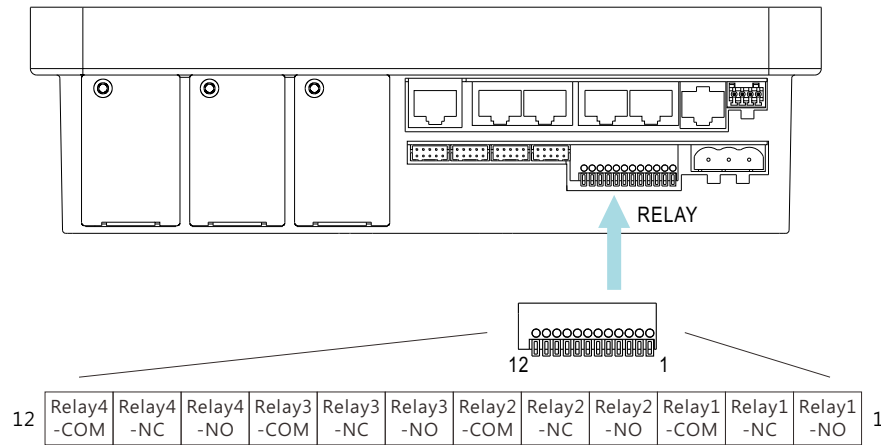

Pin No.	Function	Description
1	Relay1-NO	Normal-open contact of programmable relay1
2	Relay1-NC	Normal-close contact of programmable relay1
3	Relay1-COM	Common for relay1 NO/NC contact
4	Relay2-NO	Normal-open contact of programmable relay2
5	Relay2-NC	Normal-close contact of programmable relay2
6	Relay2-COM	Common for relay2 NO/NC contact
7	Relay3-NO	Normal-open contact of programmable relay3
8	Relay3-NC	Normal-close contact of programmable relay3
9	Relay3-COM	Common for relay3 NO/NC contact
10	Relay4-NO	Normal-open contact of programmable relay4
11	Relay4-NC	Normal-close contact of programmable relay4
12	Relay4-COM	Common for relay4 NO/NC contact

## 4.7 Pin assignment of PMBus(not supported)

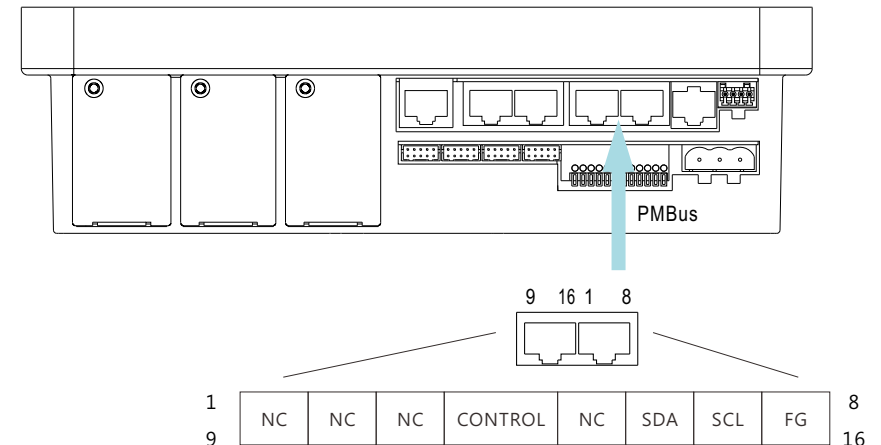

Pin No.	Function	Description
1,2,3,5,9, 10,11,13	NC	Not use
4,12	CONTROL	Remote ON/OFF control pin (Note)
6,14	SDA	Serial Data used in the PMBus interface (Note)
7,15	SCL	Serial Clock used in the PMBus interface (Note)
8,16	FG	Common FG for signal

Note: Isolated signal, with FG as reference

#### 4.8 Pin assignment of CANBus(not supported)

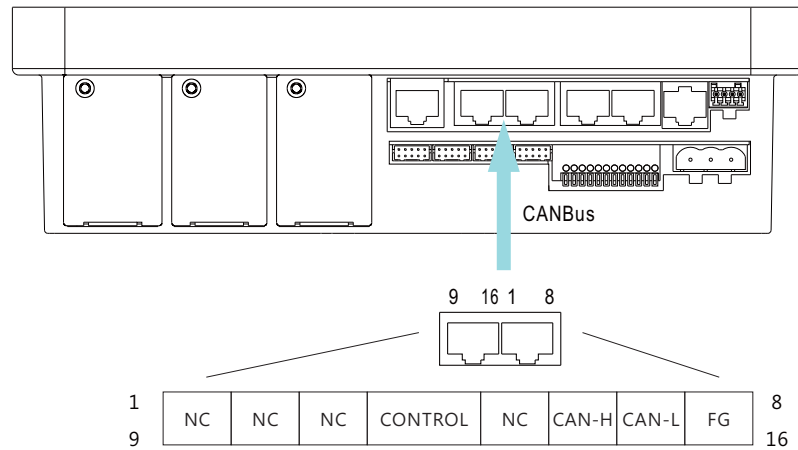

Pin No.	Function	Description
1,2,3,5,9,10,11,13	NC	Not use
4,12	CONTROL	Remote ON/OFF control pin (Note)
6,14	CAN-H	CAN-H used in the CANBus interface (Note)
7,15	CAN-L	CAN-L used in the CANBus interface (Note)
8,16	FG	Common FG for signal

Note: Isolated signal, with FG as reference

#### 4.9 Pin assignment of Ethernet

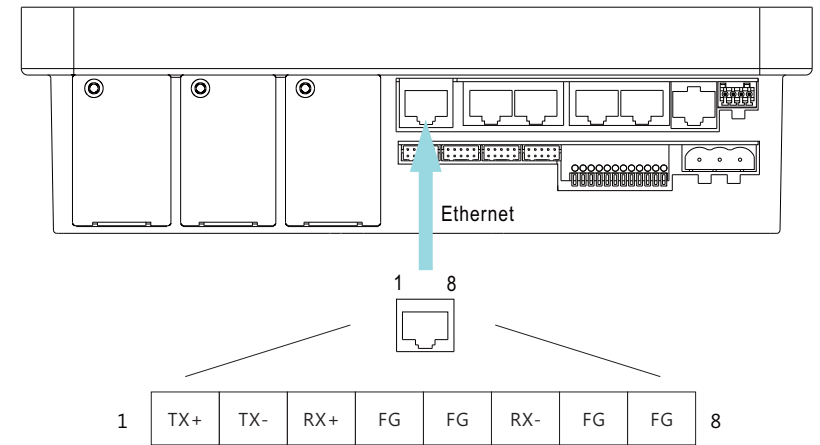

Pin No.	Function	Description
1	TX+	Transmit data used in the Ethernet interface
2	TX-	Transmit data used in the Ethernet interface
3	RX+	Receive data used in the Ethernet interface
4,5,7,8	FG	Common FG for signal
6	RX-	Receive data used in the Ethernet interface

## 4.10 Pin assignment of RS485

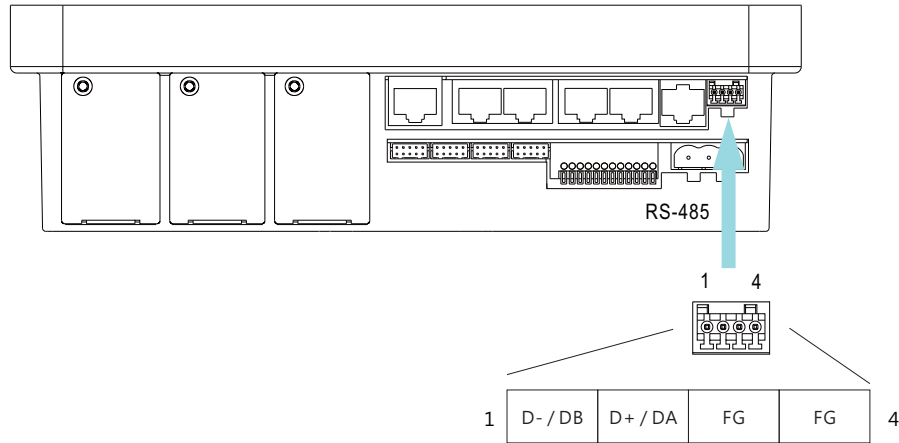

Pin No.	Function	Description
1	D- / DB	Differential digital signal used in the RS485 interface
2	D+ / DA	Differential digital signal used in the RS485 interface
3,4	FG	Common FG for signal

## 5.Operation

The CMU2E communicates with inverters via Modbus RTU to achieve operational monitoring and remote control functions. Additionally, the CMU2E supports communication interfaces of touch panel and network. Through these interfaces, the CMU2E can be integrated into system management, as illustrated below. For detailed information about its functions, please refer to the following chapters.



### 5.1 Touch panel









#### 5.1.1 Home page



After power on, the CMU2E enters the Home page automatically. On the home page, the CMU2E displays the current status of the inverter units, including number of the online inverters, AC input/output voltage. There is also a shortcut button for the ON/OFF function located in the bottom left-hand corner of the touch panel. Users can also tap the menu bar above to enter into other pages.

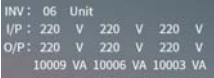

## Home options

The following functions are available on the home page :

No.	Name	Description
1	<p>Menu bar</p> 	<p>Users can enter other function pages by tapping the menu bar. There are Home, Status, Setting, Log and Info menus available. The Menu displayed on the screen will be underlined.</p> 
2	<p>Real time status By pass mode</p>  <p>Charging mode</p>  <p>Inverter mode</p> 	<p>Users can check the operational status and mode of the inverter through the screen icons.</p> <p>INV: Displays the number of inverters connected to the CMU2E (up to a maximum of 32).</p> <p>I/P and O/P: Displays the current values of AC input and output voltage. If the inverter is configured for 3-phase 4-wire output, this screen can also show the output voltage for each phase, labeled as: L1 (left), L2 (center), and L3 (right).</p>  <p> :The remaining operation time and battery capacity.</p>
3	<p>Detailed information</p> 	<p>After tapping , detailed information on the AC voltage, frequency, load conditions, and battery status for each phase will be displayed.</p>
4	<p>On/Off button icon</p> 	<p>This button can be used to turn all of the inverters connected ON or OFF simultaneously.</p>

No.	Name	Description
5	<p>SD card icon</p> 	<p>This icon is used to display whether there is a SD card connected. The SD card icon appears if there is a SD card detected.</p>
6	<p>Network icon</p> 	<p>This icon is used to display whether the network is connected. The icon appears if connected to a network.</p>
7	<p>Date and time</p>	<p>Displays date and time.</p>

### 5.1.2 Status

The status page displays operation status of the inverters, I/O signal and Relays.



#### 5.1.2.1 INV

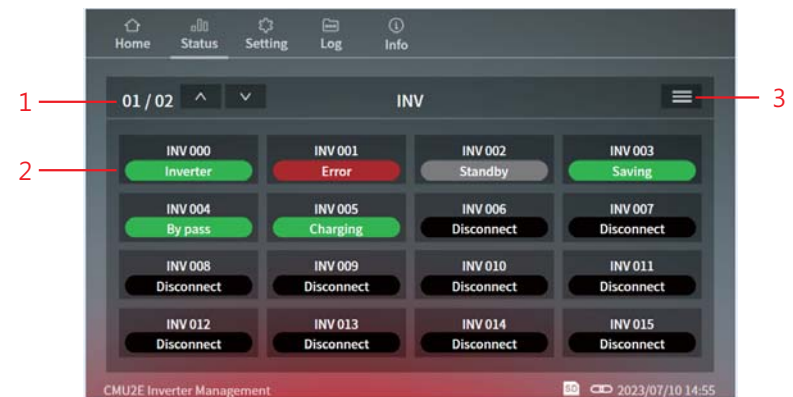

INV displays status of the inverters connected. The information includes address number, current, operation status, model name, serial number, firmware version, internal temperature, fan speed, etc.

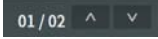

## INV-options

The following functions are available on the INV page :

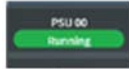
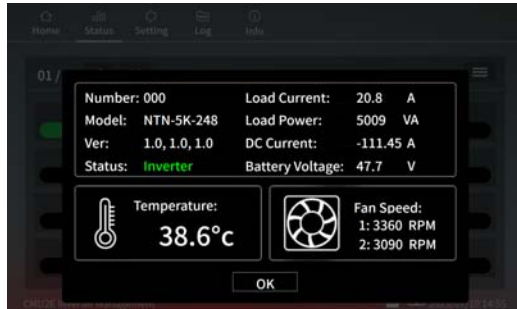
No.	Name	Description
1	Page selection 	<p>1) Users can tap  to select a desired page to display. There are two pages in total as below: 01/02: INV address 0 - 15 02/02: INV address 16 -31</p> <p>2) After tapping , it becomes five pages because more information added and displays as below: 01/04: INV address 0 - 7 02/04: INV address 8 -15 03/04: INV address 16 -23 04/04: INV address 24 -31</p>

No.	Name	Description																																													
2	Inverter operation status 	<p>1) These information boxes are used to display online and operation status of the inverters. There are four conditions: Running, Error, Remote off and Disconnect. Running: Normal working Error: The inverter is in an abnormal condition Remote off: The inverter is off Disconnect: No inverter connected</p> <p>2) Tapping a specific inverter can display more information of the unit, including serial number, firmware version, internal temperature, fan speed, etc. It can also display more detailed INV Status, including: Inverter(green), Saving(green), Bypass(green), Charging (green), Standby (gray), Error (red), and Disconnect (black)</p> 																																													
3	Change the display method 	<p>1) After tapping the icon, there are voltage, current and power adding to the box.</p> <table border="1"> <thead> <tr> <th>PSU</th> <th>Voltage</th> <th>Current</th> <th>Power</th> <th>Status</th> </tr> </thead> <tbody> <tr> <td>00</td> <td>220.17 V</td> <td>130.44 A</td> <td>32768 W</td> <td>Running</td> </tr> <tr> <td>01</td> <td>220.17 V</td> <td>130.44 A</td> <td>32758 W</td> <td>Error</td> </tr> <tr> <td>02</td> <td>220.17 V</td> <td>130.44 A</td> <td>32758 W</td> <td>Remote Off</td> </tr> <tr> <td>03</td> <td>--</td> <td>--</td> <td>--</td> <td>Disconnect</td> </tr> <tr> <td>04</td> <td>--</td> <td>--</td> <td>--</td> <td>Disconnect</td> </tr> <tr> <td>05</td> <td>--</td> <td>--</td> <td>--</td> <td>Disconnect</td> </tr> <tr> <td>06</td> <td>--</td> <td>--</td> <td>--</td> <td>Disconnect</td> </tr> <tr> <td>07</td> <td>--</td> <td>--</td> <td>--</td> <td>Disconnect</td> </tr> </tbody> </table> <p>2) In the mode, you also can display more inverter information by tapping a specific inverter</p>	PSU	Voltage	Current	Power	Status	00	220.17 V	130.44 A	32768 W	Running	01	220.17 V	130.44 A	32758 W	Error	02	220.17 V	130.44 A	32758 W	Remote Off	03	--	--	--	Disconnect	04	--	--	--	Disconnect	05	--	--	--	Disconnect	06	--	--	--	Disconnect	07	--	--	--	Disconnect
PSU	Voltage	Current	Power	Status																																											
00	220.17 V	130.44 A	32768 W	Running																																											
01	220.17 V	130.44 A	32758 W	Error																																											
02	220.17 V	130.44 A	32758 W	Remote Off																																											
03	--	--	--	Disconnect																																											
04	--	--	--	Disconnect																																											
05	--	--	--	Disconnect																																											
06	--	--	--	Disconnect																																											
07	--	--	--	Disconnect																																											

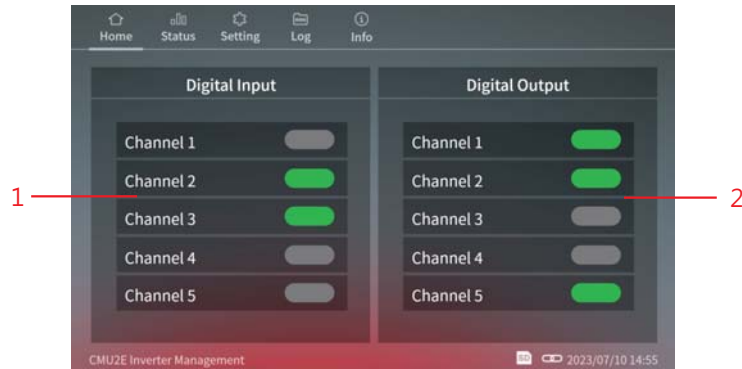

### 5.1.2.2 I/O signal

The I/O signal page displays digital status of inputs and outputs. There are 5 channels each.



#### I/O signal page - options

The following functions are available in the I/O signal page:

No.	Name	Description
1	Digital input status 	There are 2 conditions, it displays green when logic high whereas it displays gray when logic low. It remains logic high when no signal connected due to hardware design.
2	Digital output status 	There are 2 conditions where the status turns green: <ul style="list-style-type: none"> <li>The trigger condition is met &amp; Active logic is set at High.</li> <li>The trigger condition is NOT met &amp; Active logic is set at Low.</li> </ul> There are 2 conditions where the status stays gray: <ul style="list-style-type: none"> <li>The trigger condition is met &amp; Active logic is set at Low.</li> <li>The trigger condition is NOT met &amp; Active logic is set at High.</li> </ul>

### 5.1.2.3 Relay

Relay is used to display output state and setting page parameters of the four programmable relays.

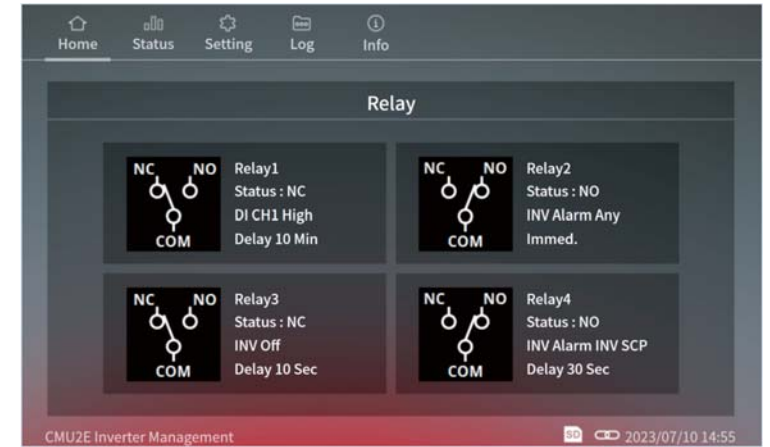

#### Relay page - options

The following functions are available in the Relay page: Trigger selections are shown as below:

Source	Trigger	Delay
Alarm	Any, OVP, OTP, OLP 150%, SCP	Immed., 1Sec, 5Sec, 10Sec, 30Sec, 1~10Min
INV	ON, OFF	
DI CH1 –DI CH5	High, Low	

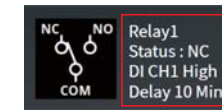

There are 2 status, if the trigger condition is met, it will display NO (normal pen), the icon is COM connected to NO; if the NO trigger condition is not met, it will display NC (normal lose), NC the icon is COM connected to NC.

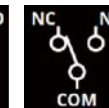

### 5.1.3 Setting

The Setting page allows users to configure settings for Inverter mode, Charger mode, I/O signal, Relay, and System. For detailed information about these functions, please refer to the following section.

#### 5.1.3.1 Inverter mode

The Inverter mode page allows users to change different values for the AC output voltage and frequency. The adjustable range is shown as below.

1XX series (such as NTN-5K-148):

100Vac/110Vac/115Vac/120Vac, 50Hz/60Hz

2XX series (such as NTN-5K-2380):

200Vac/220Vac/230Vac/240Vac, 50Hz/60Hz



Note: After setting, some models require a reboot to take effect.

#### 5.1.3.2 Charger mode

The Charger mode page allows users to set the charge curve, including 2/3 stage, CC (constant current), TC (taper current), CV (constant voltage), FV (float voltage), and timeout for each charge stage.



1. Charge parameters: There are parameters of CC (Constant Current), TC (Taper Current), CV (Constant Voltage) and FV (Float Voltage) that can be adjusted. The curve on the right-hand side will adjust automatically according to the corresponding values when the settings are changed.
2. Curve stage: 2 or 3 stages are selectable
3. Timeout (HH:MM): The timeout function allows users to set a specific time duration for charging to stop in each stage. The time format is HH (hours): MM (minutes), with a range from 1:00 to 100:00. If Curve stage is set to 2 stage, FVT (float voltage timeout) cannot be adjusted.

### 5.1.3.3 I/O signal

The I/O signal page is used to set five digital output channels to realize alarm functions you need.

Additionally, the channels also can work with digital inputs to do further applications.

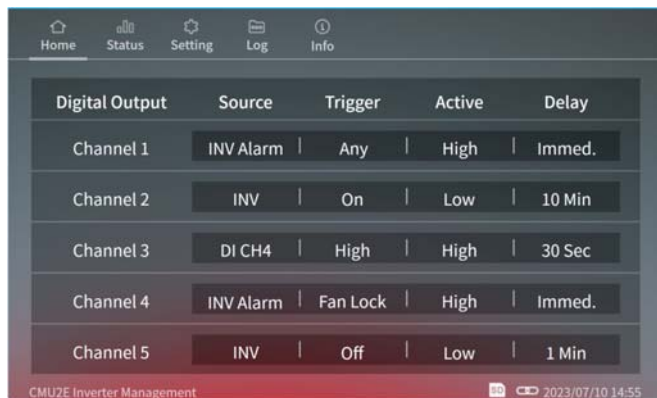

Each digital output channel can flexibly set a source, a trigger definition, an action and a delay. After tapping an output channel, triggering options will appear. Please refer to the table below for detailed triggering functions.



Source	Trigger	Active	Delay
Alarm (default)	Any (default), OVP, OTP, OLP 150%, SCP	High (default), Low	Immed.(default) · 1Sec · 5Sec · 10Sec · 30Sec · 1~10Min
INV	On, Off		
DI CH1 - DI CH5	High, Low		

Source:

Alarm, INV or digital input channels are available to be selected. After selection, the corresponding trigger conditions will appear. For instance: trigger definitions will move to relevant protection options for the rack powers when alarm is selected.

Trigger definitions:

- (1) Alarm: trigger the output channel when one of the inverters meets Any conditions, such as OVP, OLP, short circuit or any of the protections (default).
- (2) INV:
  - I. INV ON: trigger the output channel if one of the inverters is running
  - II. INV OFF: trigger the output channel if one of the inverters is remote off or in alarm conditions.
  - III. INV OFF: trigger the output channel if all of the inverters are disconnect.
- (3) DI CH1 – CH5(digital input channels): trigger the output channel according to condition of the selected input channel.

Active:

Determine the logic level when outputting. High (high level): 5V; Low (low level): 0V.

Delay:

Determine how long to delay before outputting when the trigger condition is met. There are imminently (default), 1Sec ... 10Min available.

### 5.1.3.4 Relay

The Relay page is used to set four programmable relays to realize alarm functions you need.

Additionally, the relays also can work with digital inputs to do further applications.



Each relay can flexibly set a source, a trigger definition and a delay. After tapping a relay, triggering options will appear. Please refer to the table below for detailed triggering functions.



Source	Trigger	Delay
Any (default)	Any (default), OVP, OTP, OLP 150%, SCP	Immed.(default) · 1Sec · 5Sec · 10Sec · 30Sec · 1~10Min
INV	On, Off	
DI CH1 - DI CH5	High, Low	

The COMMON is connected to the NO (Normally Open) when the trigger condition is met (shown as the right picture); The COMMON is connected to the NC (Normally Closed) when the trigger condition is NOT met (shown as the left picture).

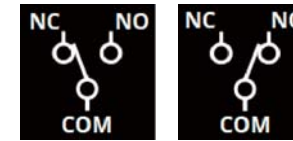

Source:

Alarm, INV or digital input channels are available to be selected. After selection, the corresponding trigger conditions will appear. For instance: trigger definitions will move to relevant protection options for the inverters when alarm is selected.

Trigger definition:

- (1) Alarm: trigger the output channel when one of the inverters meets alarm conditions, such as OVP, OLP, short circuit or any of the protections (default).
- (2) INV:
  - I. INV ON: trigger the relay if one of the inverters is running
  - II. INV OFF: trigger the relay if one of the inverters is remote off or in alarm conditions.
  - III. INV OFF: trigger the relay if all of the inverters are disconnect.
- (3) DI CH1 – CH5(digital input channels): trigger the relay according to condition of the selected input channel.

Delay:

Determine how long to delay before triggering the relay when the trigger condition is met. There are imminently (default), 1Sec ... 10Min available.

### 5.1.3.5 Misc.

The Misc. page is used to set battery settings and system operation. For Battery Setting (on the left hand side), it offers adjustments such as battery alarm and battery shutdown settings. For System Operation (on the right hand side), it provides charger enable in bypass mode and priority settings.

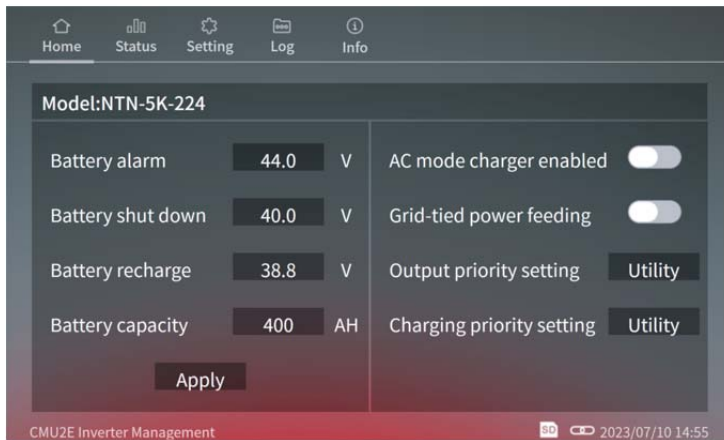

**Battery Alarm:** Determine the trigger level for the battery alarm.

**Battery shut down:** Determine the shutdown voltage level for the inverter.

**Battery recharge:** Determine the voltage level for initiating battery recharge.

**Battery capacity:** This refers to the initial capacity of the battery. Typically, this value decreases over time of usage. The CMU2E will display its current capacity based on an algorithm calculation developed by MEANWELL. The initial capacity can be found in the battery specification.

**AC mode charger enabled:** Determine whether to enable the charger to charge the battery during bypass mode.

**Grid-tied power feeding:** Determine whether to feed AC energy back to the grid when available.

**Output priority setting:** There are 2 options, Utility (default) and Battery.

Utility: Delivers AC energy from the utility or grid to the output when it is available.

Battery: Transforms stored energy from the battery into AC to power the output instead of using the grid when battery energy is available.

**Charger priority setting:** There are 2 options, Utility (default) and Solar.

Utility: Charges the battery by using the energy from the grid when it is available.

Solar: Charges the battery by the energy harvested from the solar panels instead of using the grid when it is available.

NOTE: Some of the functions may not be supported by your inverter. Please refer to its manual for detailed information.

### 5.1.3.6 System

The System page provides settings for Network, Notice, Security, log Config, Misc and Utility.

Password is required to enter the menu, the default password is "CMU2E" .

#### 5.1.3.6.1 Network

You can set the IP address on this page. The new settings will take effect after power recycling.

Address	Default
IP address	169.254.1.1
Subnet mask	255.255.0.0
Default gateway	169.254.1.1

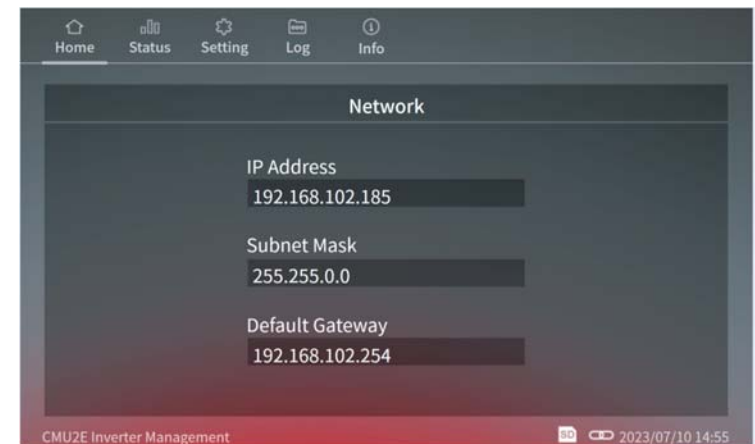

### 5.1.3.6.2 Notice

The CMU2E can send emails to notify users when the inverters is abnormal so that the issue can be investigated.

Sever IP: Set the IP address of SMTP server

User Name: Edit your user name (max 25 words)

Password: Edit your password for the SMTP (max 25 words)

Send to: Up to five emails can be set (max 25 words each)

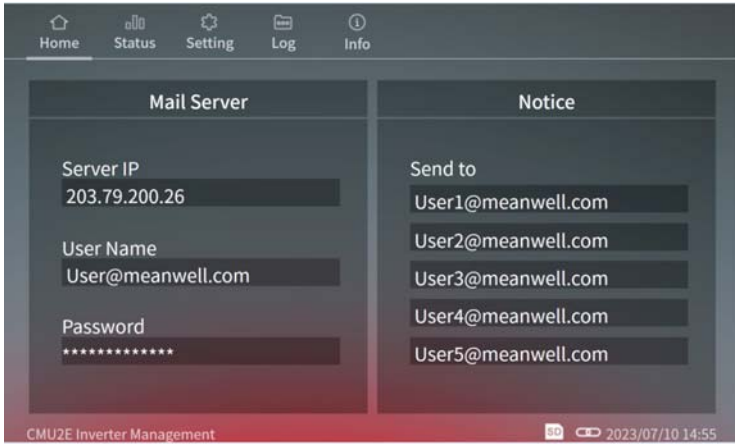

Note:

- (1) Up to 5 emails can be sent at a time, the next email will be sent after one has been sent.
- (2) The maximum content of a single mail is 3000 bytes.
- (3) Retransmission mechanism for transmission failure is 3 times, with 10min time interval.
- (4) Email sends when there is any new event log that occurs.

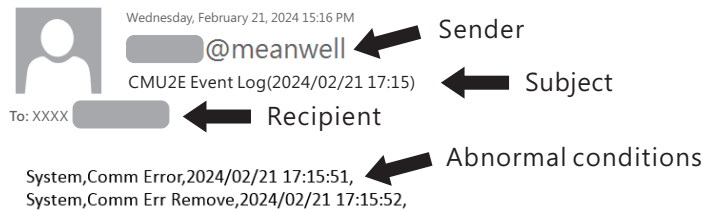

### 5.1.3.6.3 Security

You can change your password in this page, with max 15 words.

Please input the old and new passwords and then tap Apply to change the password.

The default password: CMU2E.



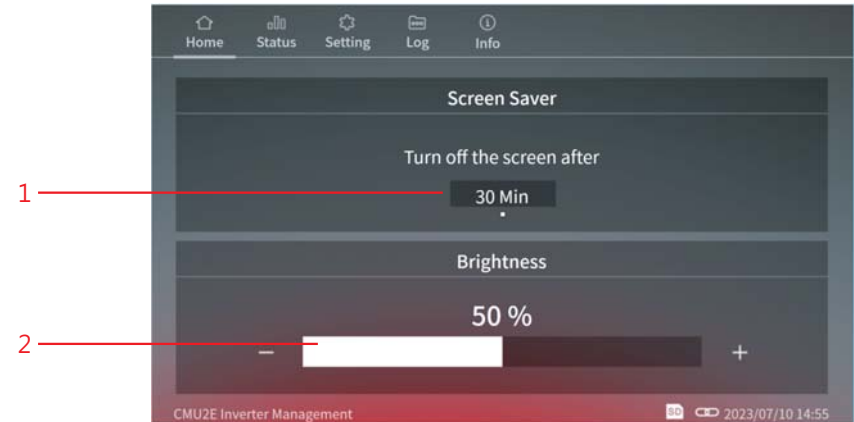

### 5.1.3.6.4 Screen

This page provides functions for setting turn off time for the screen and brightness.

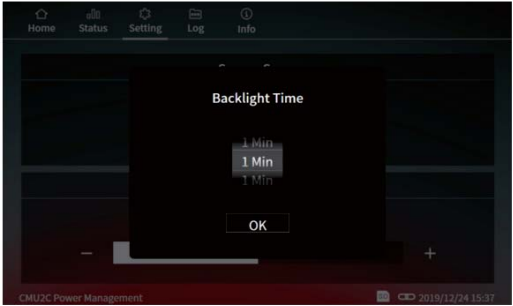

### Screen page – options

The following functions are available in screen page:

No.	Name	Description
1	Screen saver	Tap the box to select a certain time to turn off the screen. There are 8 options: 1Min, 5Min, 10Min, 20Min, 30Min, 1Hr, 2Hr and Never. (Default: Never)  
2	Brightness	There are 10 options for brightness setting, 10% - 100%. (Default: 50%) 

#### 5.1.3.6.5 Log Config.

The log config. page provides relevant settings for data log and event log, including data log interval, clear data log and clear event log.

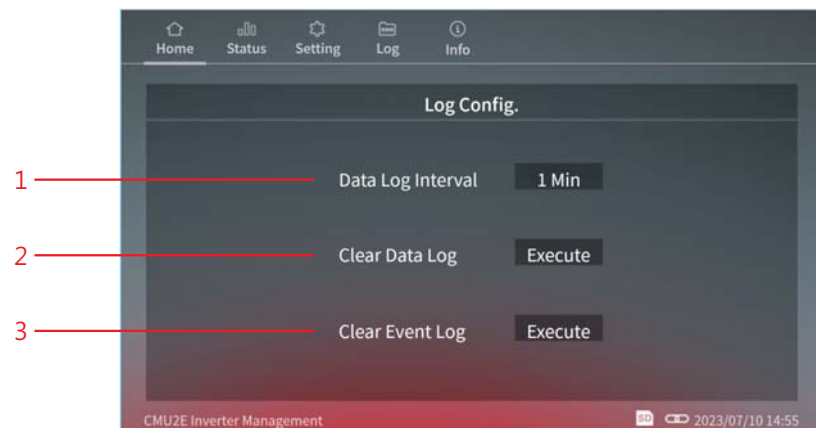

### Log Config. page – options

The following functions are available in Log Config. page:

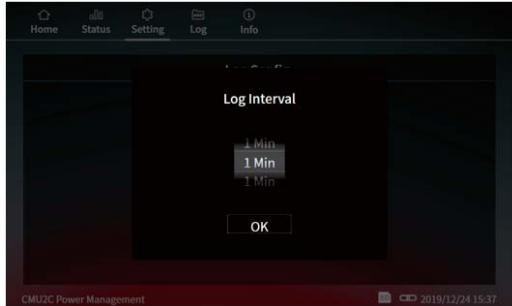
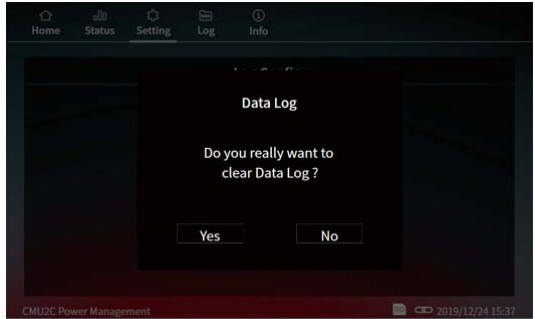
No.	Name	Description
1	Data log interval	Tap the box to select a certain interval to record operation data of the inverters. There are 9 options: 1Min, 2Min, 5 Min, 10 Min, 20 Min, 30 Min, 40 Min, 50Min, 1Hr. (Default: 1Min)  
2	Clear Data Log	This function is used to delete the saved data log permanently. Tap "Execute" then "Yes" to remove the data. 

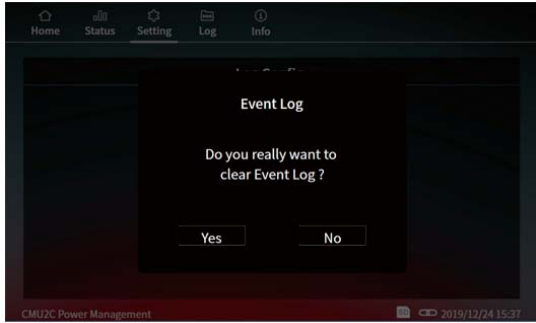
No.	Name	Description
3	Clear Event Log	<p>This function is used to delete the saved event log permanently.</p> <p>Tap "Execute" then "Yes" to remove the data.</p> 

#### 5.1.3.6.6 Misc.

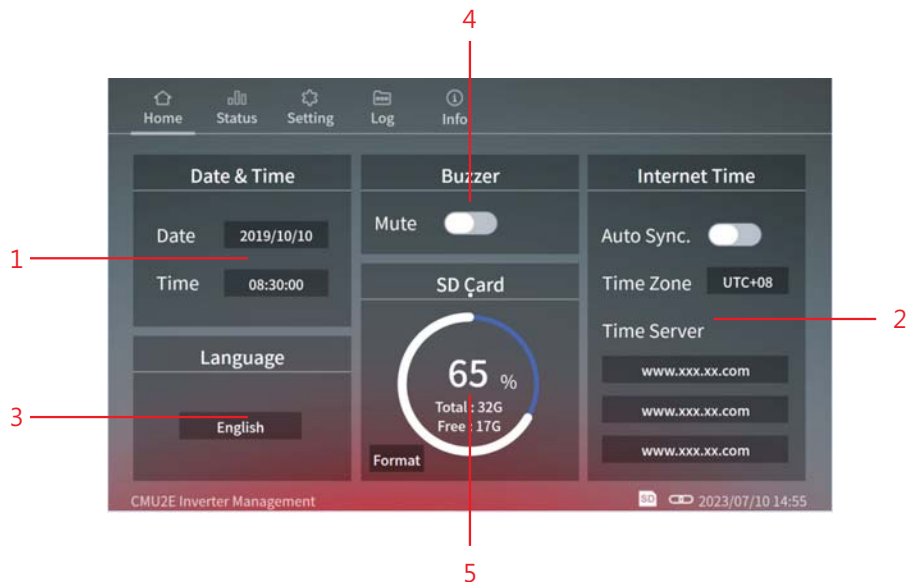

This page provides settings for Date & Time, language selection, buzzer enabling and SD card formatting.



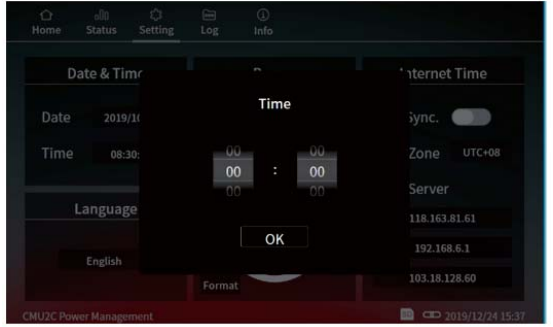

#### Misc. page – options

The following functions are available in Log Misc. page:

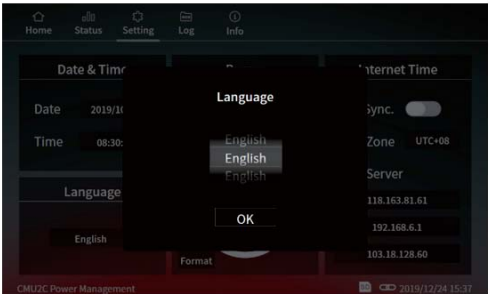
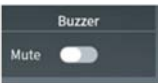
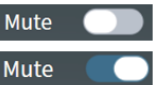
No.	Name	Description
1	Date & Time	<p>Tapping the boxes can change the date and time.</p> <p>Date setting:</p>  <p>Time setting:</p>  <p>Note: Settings for Date &amp; Time becomes invalid when auto-synchronization with internet time is enabled.</p>

No.	Name	Description
2	Synchronization with internet time 	<p>1) Choose whether to synchronize the clock with an internet time.</p> <p>2) There are 25 options for time zone selection, UTC-12 - UTC+12. (Default: UTC+08)</p> <p>3) Up to 3 internet time servers available to be set, using IP addresses. (Default: Time Server 1 : 118.163.81.61 &lt;TW&gt; Time Server 2 : 114.118.7.163 &lt;CN&gt; Time Server 3 : 82.161.251.125 &lt;EU&gt;)</p>
3	Language selection 	<p>There are English, Traditional Chinese and Simplified Chinese selectable.</p> 
4	Buzzer enabling 	<p>When mute is disabled, a blue switch is displayed; when mute is enabled, a gray switch is displayed (Default: disabled)</p> 

Note: The CMU2E utilises a super capacitor as an energy source to drive the internal clock while power off. The date & time will return to default setting when the capacitor runs flat. We suggest synchronising the clock with an internet time to calibrate the time automatically, if not possible turn on the CMU2E to recharge the capacitor at least once every three days.

No.	Name	Description
5	SD card formatting 	<p>It displays the SD card capacity and usage information.</p> <p>Tap "Execute" then "Yes" to format the SD card.</p> 

#### 5.1.3.6.7 Utility

This page displays firmware versions of the system host, communication and extension cards and provides the factory resetting function.

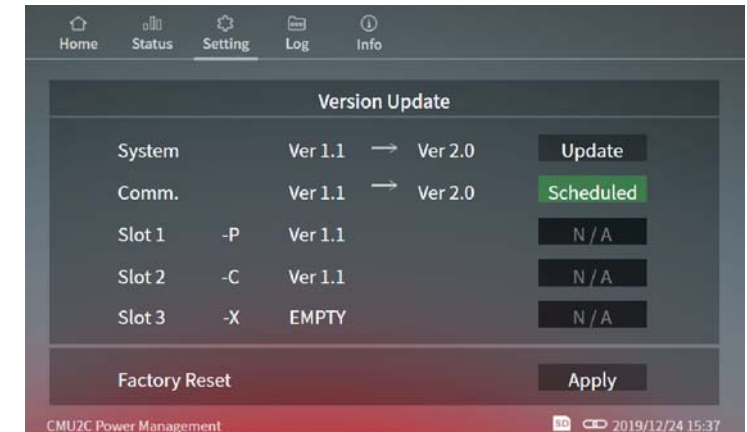

#### 5.1.4 Log

The CMU2E provides data log and event log for users to view operation status and diagnose problems that might arise.

Note: Please insert a SD card to enable data log and event log.

### 5.1.4.1 Data log

Data Log stores the measurement data at selected intervals and provides a full history database for users to extract and load. One page can display 8 data and there are 180 pages in total in the system. A maximum of 1440 data can be recorded on a day. The maximum number of data that can be displayed is 360. If you would like to access previous data, please use the "Data in certain time" function or refer to section 3 for more information.

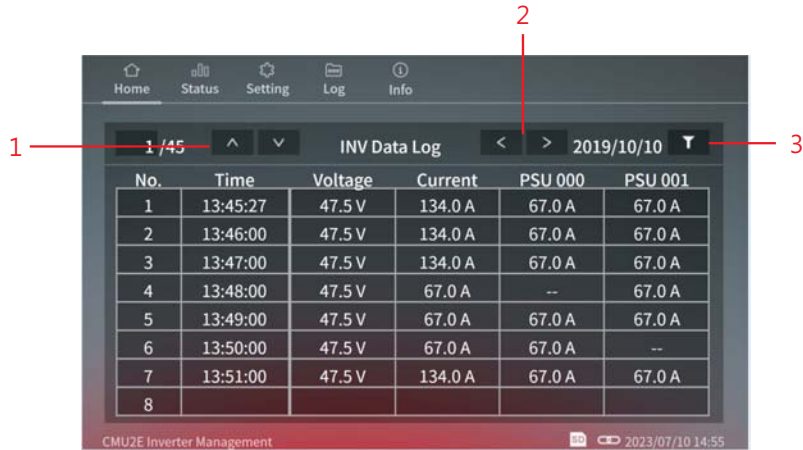

#### Data log page – options

The following functions are available in Data Log page:

No.	Name	Description
1	Page selection	<p>1) 「^」 「v」 can be used to select pages, single tap to display the next or previous pages. (Tap 「^」 on the first page will jump to page 45 and vice versa)</p> <p>2) To jump to a certain page, you can tap <b>1/45</b> to use the keyboard.</p> 

No.	Name	Description
2	Data selection	「<」 「>」 can be used to select operation information that wants to view, including bus voltage, current in total or in single.
3	Data in certain time	To jump to a certain date and time, you can tap the icon to use the scroll wheel. 



### 5.1.4.2 Event log

Event Log stores information about all abnormal events that occur in the system. One page can display 8 data and there are 1000 pages in total in the system.



## Event Log page – options

The following functions are available in Event Log page:

No.	Name	Description
1	Page Selection	<p>1) 「^」 「v」 can be used to select pages, single tap to display the next or previous pages. (Tap 「^」 on the first page will jump to page 1000 and vice versa)</p> <p>2) To jump to a certain page, you can tap <b>1, 1000</b> to use the keyboard.</p> 
2	Data in Certain Time	<p>To jump to a certain date and time, you can tap the icon to use the scroll wheel.</p> 

## 5.2 Web-based User Interface

### 5.2.1 System requirements

◎System requirements

- 1.Windows 10
- 2.AMD or Intel Pentium 133MHz or better based computer
- 3.10/100 BASE-T Ethernet port
- 4.Google Chrome, Firefox or Microsoft Edge

### 5.2.2 Connection and IP setting

◎Connection diagram

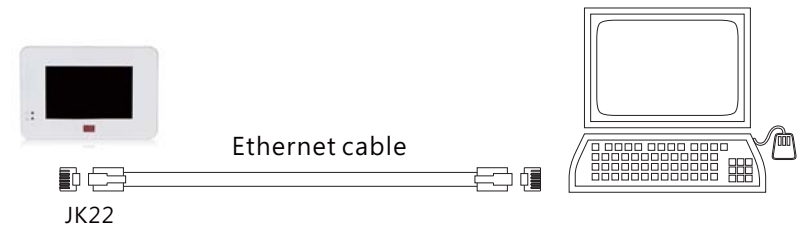

◎ Before accessing to the built-in web page, please make sure that the CMU2E and the PC are set in the same domain. Please refer to IP setting for detail.

※ Default IP address setting

Address	Default
IP address	169.254.1.1
Subnet mask	255.255.0.0
Default gateway	169.254.1.1

◎IP setting

You can change IP address setting of the CMU2E to let your local network to identify the device or you also can change IP address setting of your PC to access to the CMU2E. Please follow the instruction below to set IP address of your PC.

- ① Only connect the PC to the CMU2E and make sure there is no other devices connected to the PC.
- ② Click the "Network and Internet Connections" option. Then click the "Local Area Connection". Select "Internet Protocol (TCP/IP)", and then click the "Properties" button. If there are "Internet Protocol Version 4 (TCP/IPv4)" and "Internet Protocol Version 6(TCP/IPv6)" shown on the table, choose "Internet Protocol Version 4 (TCP/IPv4)".

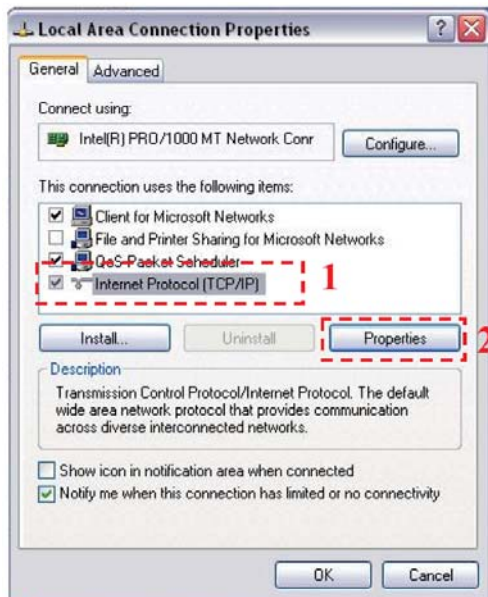

- ③ Click the "Use the following IP address" and then type addresses in "IP address", "Subnet mask" and "Default gateway" boxes, after that click the "OK" button. The IP address you set should be in the same domain as CMU2E but not the identical IP. Here is an example below for your reference.

Address	Default (for ex.)
IP address	169.254.1.1
Subnet mask	255.255.0.0
Default gateway	169.254.1.1

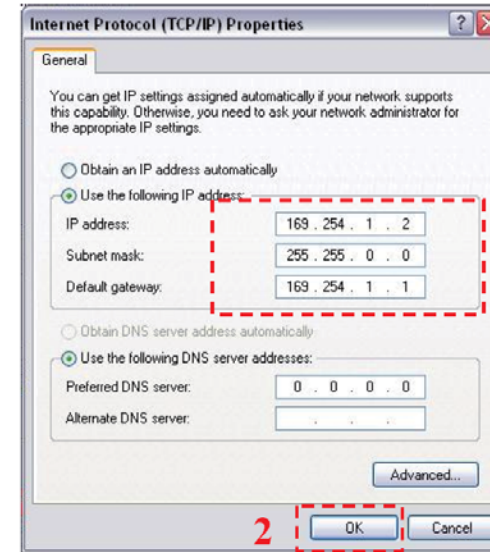

- ④ Check if it is working correctly by clicking the "Support" button. If the addresses presented as you typed, it is successfully done. Then you can access the built-in web page.

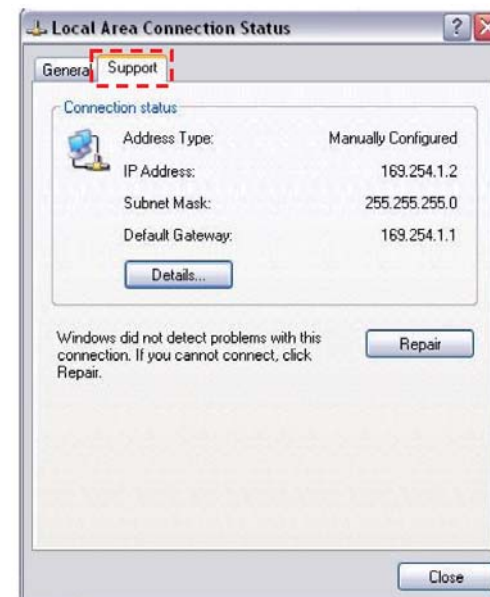

If the table shows below, it means that your RJ-45 cable is not connected properly or the IP address you set is incorrect.



### 5.2.3 How to Open the Web Page

Connect your PC to the CMU2E, then open a blank page and type the IP address of the CMU2E in the address bar. If you are not sure the IP address of the CMU2E, refer to the touch panel interface.

The route is "Setting" → "System" → "Network". (Default IP: 169.254.1.1)

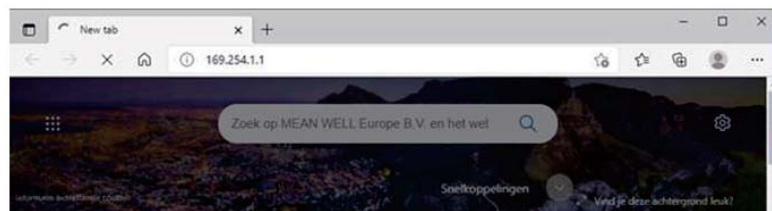

### 5.2.4 HOME

The HOME page of the built-in web displays output power, number of INV connected, bus voltage, total current, information on firmware versions. Users can enter other pages by clicking the menu bar, located in the top-right corner.

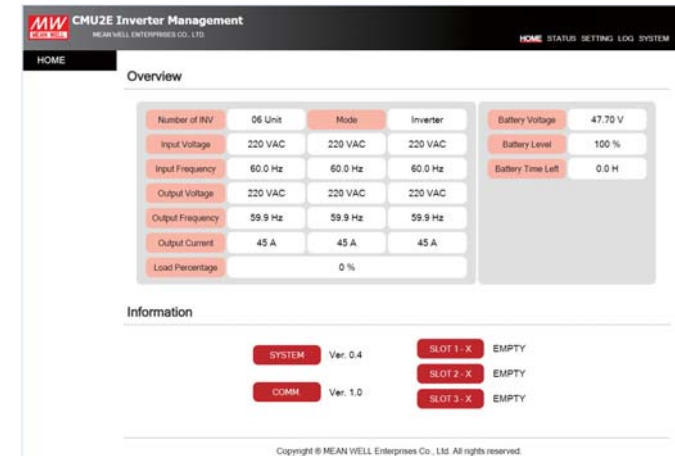

### 5.2.5 STATUS

The STATUS page displays status of INVs, digital I/O and relays.

#### 5.2.5.1 INV Status

The INV Status page displays information of address number, power wattage, current, temperature, model name, serial number, firmware version, alarm and online status.



### 5.2.5.2 Digital/Relay

This page displays status of the digital input/ output and relays.

- **Digital Input/ Output**

Digital Input: There are 2 conditions, it displays green when logic high whereas it displays gray when logic low. It remains logic high when no signal connected due to hardware design.

Digital Output: There are 2 conditions, it displays green when the trigger condition is met whereas it displays gray when the trigger condition is not met.

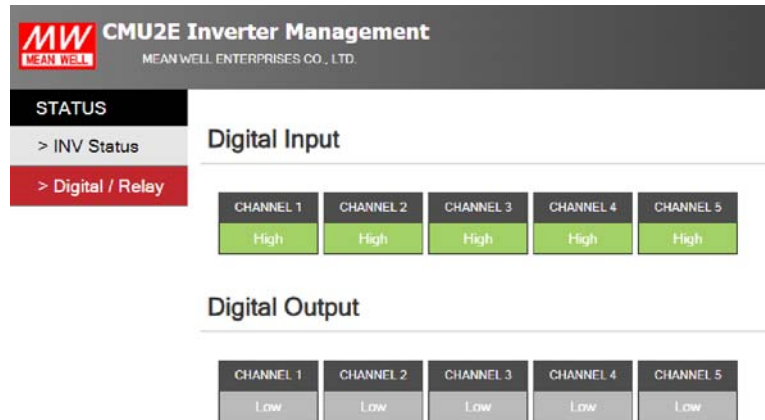

- **Relay**

Relay displays output state and setting parameters of the four programmable relays, including relay status, source, trigger and delay. If the trigger condition is met, it will display NO (Normal Open) in green; if the trigger condition is not met, it will display NC (Normal Close) in gray.

STATUS				
> PSU Status				
> Digital / Relay				
Relay1				
STATUS	SOURCE	TRIGGER	DELAY	
NO	DI CH1	High	Immed.	
Relay2				
STATUS	SOURCE	TRIGGER	DELAY	
NC	DI CH2	Low	Immed.	
Relay3				
STATUS	SOURCE	TRIGGER	DELAY	
NC	DI CH3	Low	Immed.	
Relay4				
STATUS	SOURCE	TRIGGER	DELAY	
NC	Alarm	OLP	Immed.	

The conditions from SOURCE, TRIGGER and DELAY that can be displayed is shown in the table below:

SOURCE	TRIGGER	DELAY
Alarm	Any, OVP, OTP, OLP 150%, SCP	Immed., 1 Sec, 5 Sec, 10 Sec, 30 Sec, 1 ~ 10 Min
INV	On · Off	
DI CH1 – DI CH5	High · Low	

### 5.2.6 SETTING

The SETTING page offers comprehensive configurations for system operation and battery settings. It includes options to enable/disable charging mode, AC output voltage and frequency adjustment, and charging curve settings. Additionally, it provides settings for Digital/Relay, including digital input/output channels and relay configurations. The specific functionalities of each sub-page will be detailed in subsequent sections.

#### 5.2.6.1 Battery Setting and System Operation

This page provides detailed settings for both battery and inverter operation. For Battery Setting, it offers adjustments such as battery alarm and battery shutdown settings. For System Operation, it provides options to turn the inverter on/off, charger enable in bypass mode, priority settings, and adjustments for output and frequency.

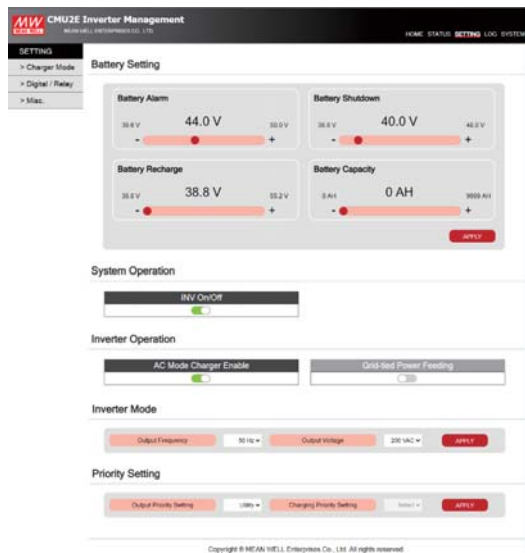

### Battery Setting

**Battery Alarm:** Determine the trigger level for the battery alarm.

**Battery shut down:** Determine the shutdown voltage level for the inverter.

**Battery recharge:** Determine the voltage level for initiating battery recharge.

**Battery capacity:** This refers to the initial capacity of the battery. Typically, this value decreases over time of usage. The CMU2E will display its current capacity based on an algorithm calculation developed by MEANWELL. The initial capacity can be found in the battery specification.

### System Operation

**INV ON/OFF:** This function can be used to turn on/off the inverters at once.

### Inverter Operation

**AC mode charger enabled:** Determine whether to enable the charger to charge the battery during bypass mode.

**Grid-tied power feeding:** Determine whether to feed AC energy back to the grid when available.

### Inverter Mode

**Output Frequency and Output Voltage:** The adjustable range is shown as below.

1XX series (such as NTN-5K-148):

100Vac/110Vac/115Vac/120Vac, 50Hz/60Hz

2XX series (such as NTN-5K-2380):

200Vac/220Vac/230Vac/240Vac, 50Hz/60Hz

### Priority Setting

**Output priority setting:** There are 2 options, Utility (default) and Battery.

**Utility:** Delivers AC energy from the utility or grid to the output when it is available.

**Battery:** Transforms stored energy from the battery into AC to power the output instead of using the grid when battery energy is available.

**Charger priority setting:** There are 2 options, Utility (default) and Solar.

**Utility:** Charges the battery by using the energy from the grid when it is available.

**Solar:** Charges the battery by the energy harvested from the solar panels instead of using the grid when it is available.

**NOTE:** Some of the functions may not be supported by your inverter. After setting, some models require a reboot to take effect. Please refer to its manual for detailed information.

### 5.2.6.2 Charger Mode

The Charger Mode page allows users to set the charge curve, including 2/3 stage, CC (constant current), TC (taper current), CV (constant voltage), FV (float voltage), and timeout for each charge stage.

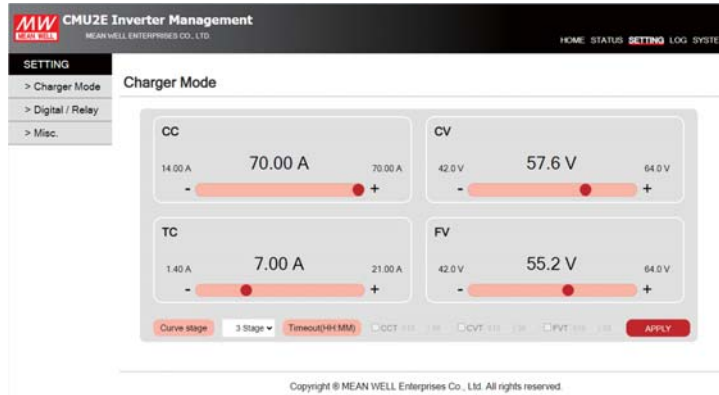

### 5.2.6.3 Digital/Relay

This page is used to set functions of the digital I/O channels and relays.

- **Digital Output**

Each digital output channel can flexibly set a source, a trigger definition, an action and a delay.

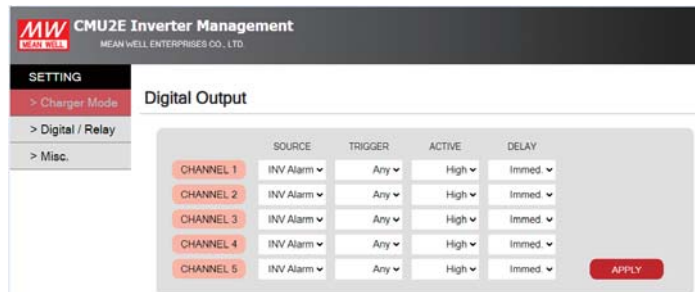

After setting, click **APPLY** to write your new parameters. Please refer to the table below for detailed triggering functions.

SOURCE	TRIGGER	ACTIVE	DELAY
Alarm (default)	Any (default), OVP, OTP, OLP 150%, SCP	High (default), Low	Immed.(default), 1 Sec, 5 Sec, 10 Sec, 30 Sec, 1 ~10 Min
INV	On \ Off		
DICH1-DICH5	High \ Low		

Source:

Alarm, INV or digital input channels are available to be selected. After selection, the corresponding trigger conditions will appear. For instance: trigger definitions will move to relevant protection options for the rack powers when alarm is selected.

Trigger definitions:

- (1) Alarm: Trigger the output channel when one of the inverter meets alarm conditions, such as OVP, OLP, short circuit or any of the protections (default).
- (2) INV: I. INV ON: Trigger the output channel if one of the inverter is running  
II. INV OFF: Trigger the output channel if one of the inverter is remote off or in alarm conditions.  
III. INV OFF: Trigger the output channel if all of the inverter are disconnect.
- (3) DI CH1 – CH5 (digital input channels): Trigger the output channel according to condition of the selected input channel.

Active:

Determine the logic level when outputting. High (high level): 5V; Low (low level): 0V.

Delay:

Determine how long to delay before outputting when the trigger condition is met. There are imminently (default), 1Sec ... 10Min available.

- **Relay**

Relay is used to set four programmable relays to realize alarm functions you need. In addition, the relays also can work with digital inputs to do further applications.

STATUS		Relay1			
> PSU Status					
> Digital / Relay		STATUS	SOURCE	TRIGGER	DELAY
		NO	DI CH1	High	Immed.
Relay2		STATUS	SOURCE	TRIGGER	DELAY
		NC	DI CH2	Low	Immed.
Relay3		STATUS	SOURCE	TRIGGER	DELAY
		NC	DI CH3	Low	Immed.
Relay4		STATUS	SOURCE	TRIGGER	DELAY
		NC	Alarm	OLP	Immed.

Each relay can flexibly set a source, a trigger definition and a delay. After setting, click **APPLY** to write your new parameters. Please refer to the table below for detailed triggering functions.

SOURCE	TRIGGER	DELAY
Alarm (default)	Any (default), OVP, OLP, Short, OTP, AC-Fail, Fan Lock	Immed.(default) \ 1Sec \ 5Sec \ 10Sec \ 30Sec \ 1~10Min
INV	On, Off	
DI CH1 - DI CH5	High, Low	

Source:

Alarm, INV or digital input channels are available to be selected. After selection, the corresponding trigger conditions will appear. For instance: trigger definitions will move to relevant protection options for the rack powers when alarm is selected.

Trigger definition:

- (1) Alarm: Trigger the output channel when one of the supplies meets alarm conditions, such as OVP, OLP, short circuit or any of the protections (default).
- (2) INV: I. INV ON: Trigger the relay if one of the inverter is running  
II. INV OFF: Trigger the relay if one of the inverter is remote off or in alarm conditions.  
III. INV OFF: Trigger the relay if all of the inverter are disconnect.
- (3) DI CH1 – CH5 (digital input channels): Trigger the relay according to condition of the selected input channel.

Delay:

Determine how long to delay before triggering the relay when the trigger condition is met. There are imminently (default), 1Sec ... 10Min available.

### 5.2.7 LOG

LOG page provides data log and event log for users to view operation status and diagnose problems that might arise. Note: Please insert a SD card to enable data log and event log.

#### 5.2.7.1 Data log

Data Log stores the measurement data at selected intervals and provides a full history database for users to extract and download. Date displays with a red dot if there is recorded data. For example: **14**; If there is no data recorded, then the date will be shown without red dot. The data is readable in .CSV format, click the date you want to view to download it.



Note: FireFox does not support a date picker function, users has to enter date manually.

#### Data Log information

Time	Bus Voltage(V)	Total Current(A)	INV 0 Current(A)	INV 1 Current(A)	INV 2 Current(A)	INV 3 Current(A)	INV 4 Current(A)	INV 5 Current(A)	INV 6 Current(A)
2024/3/15 08:51	...	...	...	...	...	...	...	...	...
2024/3/15 08:52	...	...	...	...	...	...	...	...	...
2024/3/15 08:53	...	...	...	...	...	...	...	...	...
2024/3/15 08:55	...	...	...	...	...	...	...	...	...
2024/3/15 08:59	...	...	...	...	...	...	...	...	...
2024/3/15 09:01	...	...	...	...	...	...	...	...	...
2024/3/15 09:03	...	...	...	...	...	...	...	...	...
2024/3/15 09:04	...	...	...	...	...	...	...	...	...
2024/3/15 09:05	...	...	...	...	...	...	...	...	...
2024/3/15 09:06	...	...	...	...	...	...	...	...	...
2024/3/15 09:07 220V	22.74A	...	...	...	...	...	...	...	...
2024/3/15 09:08 220V	22.74A	...	...	...	...	...	...	...	...
2024/3/15 09:09 220V	22.74A	...	...	...	...	...	...	...	...
2024/3/15 09:10 220V	22.74A	...	...	...	...	...	...	...	...
2024/3/15 09:11 220V	22.74A	...	...	...	...	...	...	...	...
2024/3/15 09:12 220V	22.74A	...	...	...	...	...	...	...	...
2024/3/15 09:15	...	...	...	...	...	...	...	...	...
2024/3/15 09:16	...	...	...	...	...	...	...	...	...
2024/3/15 09:17	...	...	...	...	...	...	...	...	...
2024/3/15 09:18	...	...	...	...	...	...	...	...	...
2024/3/15 09:19	...	...	...	...	...	...	...	...	...
2024/3/15 09:20	...	...	...	...	...	...	...	...	...
2024/3/15 09:21	...	...	...	...	...	...	...	...	...

#### 5.2.7.2 Event log

Event Log stores information about all abnormal events that occur in the system. Month displays with a red dot if there is recorded data. For example: **3** ; If there is no data recorded, then the month will be shown without red dot. The data is readable in CSV format, click the month you want to view to download it.

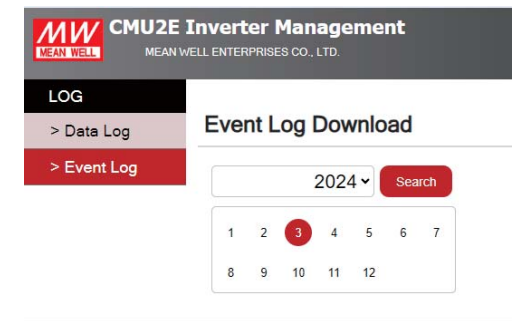

	A	B	C
1	Device	Event	Date & Time
2	INV_16	SCP	2024/3/7 15:20
3	INV_16	SCP Remove	2024/3/7 15:21
4	System	Comm Error	2024/3/15 08:59
5	System	Comm Error	2024/3/15 09:00
6	System	Comm Err Remove	2024/3/15 09:00
7	INV_22	OLP 100%	2024/3/15 09:06
8	INV_22	OLP 100% Remove	2024/3/15 09:06
9	INV_22	OLP 100%	2024/3/15 09:07
10	INV_22	OLP 100%	2024/3/15 09:09
11	System	Comm Error	2024/3/15 09:09
12	System	Comm Error	2024/3/15 09:14
13	INV_22	OLP 100%	2024/3/15 09:44
14	INV_22	OLP 100% Remove	2024/3/15 09:44

#### 5.2.8 System

SYSTEM page provides setting of Network, Notice, Security and Data/Event Log.

##### 5.2.8.1 Network

Network page provides IP address setting. The new settings will take effect after power recycling.

IP address	Default
IP address	169.254.1.1
Subnet mask	255.255.0.0
Default gateway	169.254.1.1



### 5.2.8.2 Notice

The CMU2 can send emails to notify users when the system power is abnormal so that the issue can be investigated.

#### Mail Server

Sever IP: Set the IP address of SMTP server

User Name: Edit your user name (max 25 words)

Password: Edit your password for the SMTP (max 25 words)

#### Notice

Send to: Up to five emails can be set (max 25 words each)

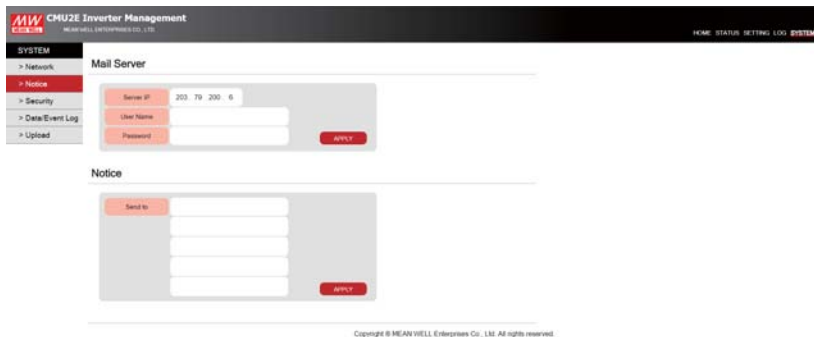

Note:

- (1) Up to 5 emails can be sent at a time, the next email will be sent after one has been sent.
- (2) The maximum content of a single mail is 3000 bytes.
- (3) Retransmission mechanism for transmission failure is 3 times, with 10min time interval.
- (4) Email sends when there is any new event log that occurs.

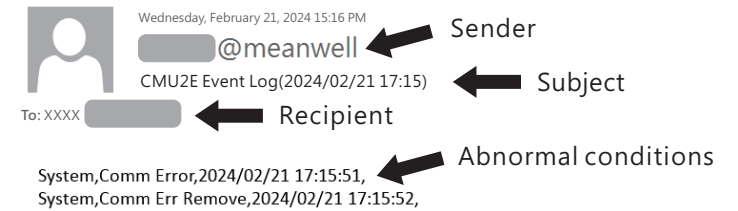

### 5.2.8.3 Security

You can change your password in this page, with max 15 words. Please input the old and new passwords and then tap **APPLY** to change the password.

The default password: CMU2E.

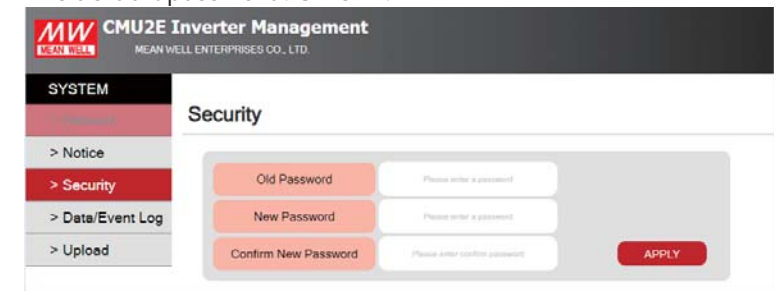

### 5.2.8.4 Data/Event Log

This page provides relevant settings for data log and event log, including data log interval, clear data log and clear event log.

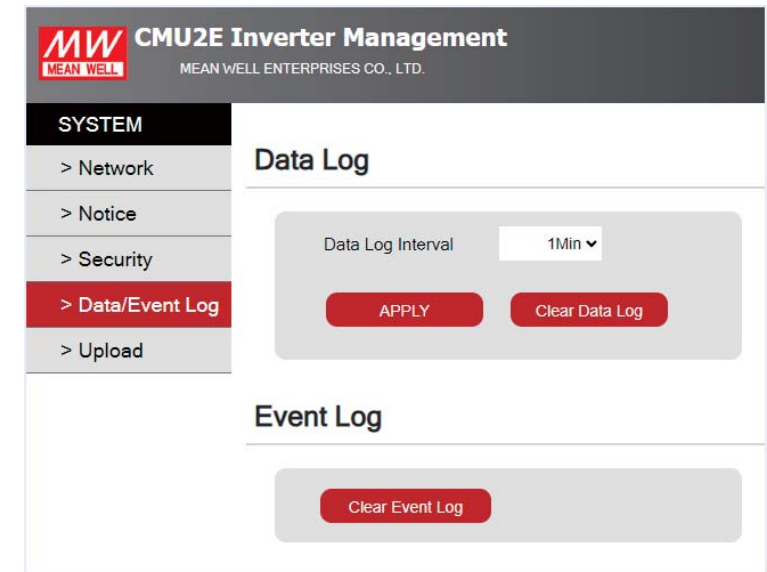

- **Data Log**

Click the box to select a certain interval to record operation data of the rack powers.

There are 9 options: 1Min, 2Min, 5 Min, 10 Min, 20 Min, 30 Min, 40 Min, 50Min, 1Hr. (Default: 1Min)

Clicking **Clear Data Log** can remove data log recorded.

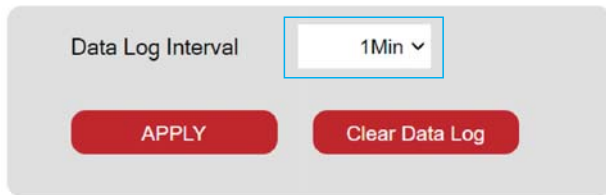

- **Event Log**

Clicking **Clear Data Log** can remove event log recorded.



### 5.2.7 LOG

The LOG page provides data log and event log functions, allowing users to confirm the usage of system power.

Note: Please install SD card to enable log function.

## 5.3 Modbus TCP Interface

The device supports Modbus TCP communication protocol. Clients are able to read and write parameters of the CMU2E (server) through the protocol, including remote ON/OFF, output voltage/frequency setting, INV internal temperature reading, etc. During data transfer, please follow the principle of first sending the Hi byte and then the Lo byte.

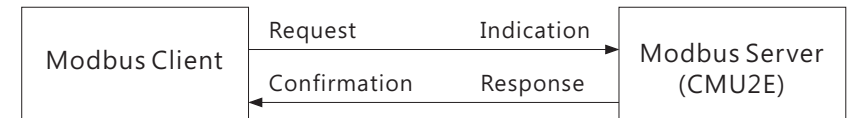

All Modbus TCP Message Frames are sent via TCP on registered port 502. For the IP Address, please refer to Network page of the CMU2E

### 5.3.1 Communication Timing

Min. request period (Controller(client) to CMU2E(Server)): 20mSec °

Max. response time (CMU2E(Server) to Controller(client)): 5mSec °

Min. packet margin time (Controller(client) to CMU2E(Server)): 5mSec °

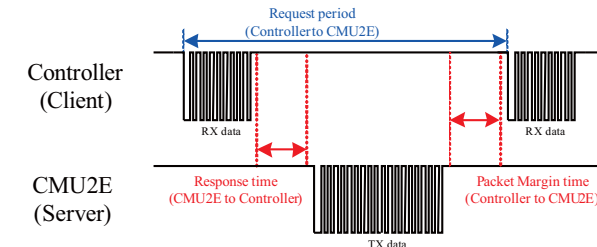

### 5.3.2 Modbus Frame Encapsulation

Modbus TCP message framing consists of MBAP Header, Function Code and Data.

MBAP Header	Function Code	Data
7 bytes	1 byte	N bytes

MBAP Header (7bytes) : It is a dedicated header that is used on TCP/IP to identify the Modbus Application Data Unit.

Function code (1byte) : The function codes are used to tell the server what kind of action to perform.

Data (N bytes) : For data exchange, contents and data length are dependent on different function codes.

### 5.3.3 MBAP Header Definition

MBAP Header consists of the following parts:

Fields	Length	Description
Transaction Identifier	2 bytes	Identification of a Modbus Request / Response transaction. Initialized by the client and recopied by the server from the received request.
Protocol Identifier	2 bytes	0 = Modbus TCP, meaning a PDU communication protocol.
Length	2 bytes	Number of following bytes, including Unit Identifier, Function code and Data Fields.
Unit Identifier	1 byte	Identification of a remote slave connected on a serial line or on other buses. Initialized by the client and recopied by the server from the received request (Not for the purpose of Modbus TCP to RTU gateway)

### 5.3.4 Function Code Description

The main purpose of the function codes is to tell the server what kind of action to perform. For example: Function code 03 will query the server to read holding registers and respond with their contents.

Code	Function
0x03	Read Holding Register
0x04	Read Input Register
0x06	Preset Single Register
0x10	Write Multiple Register
0x64	Read Array Log
0x65	Read Single machine status

### 5.3.5 Data Field and Command Lists

Data field provides additional information by the server to complete the action specified by the function code in the client's request. The data field typically includes register addresses, count values, and written data. There are several forms according to the function codes.

FC = 0x03

Request:

Starting Address	Quantity of Registers
2 Bytes	2 Bytes

Response:

Byte Count	Register Value
1 Byte	N* x 2 Bytes

N\* = Quantity of Registers

FC = 0x04

Request:

Starting Address	Quantity of Input Registers
2 Bytes	2 Bytes

Response:

Byte Count	Input Register
1 Byte	N* x 2 Bytes

N\* = Quantity of Registers

FC = 0x06

Request:

Register Address	Register Value
2 Bytes	2 Bytes

Response:

Starting Address	Register Value
2 Bytes	2 Bytes

FC = 0x10

Request:

Starting Address	Quantity of Registers	Byte Count	Registers Value
2 Bytes	2 Bytes	1 Byte	N* x 2 Bytes

N\* = Quantity of Registers

Response:

Starting Address	Quantity of Registers	Byte Count	Registers Value
2 Bytes	2 Bytes	1 Byte	N* x 2 Bytes

FC = 0x64

Request:

Starting Address	Quantity of Input Registers
2 Bytes	2 Bytes

Response:

Byte Count	Input Register
1 Byte	N* x 2 Bytes

FC = 0x65

Request:

Starting Address	Quantity of Input Registers	Types	Command
2 Bytes	2 Bytes	1 Byte	1 Byte

Response:

Byte Count	Register value
N*2	N* x 2 Bytes

N = Quantity of Registers · N maximum is 125

Register Addresses	Command Name	Supported Function Codes	# of data Bytes	Description
0x0050	READ_VIN_RS(L1-L2)	0x04	2	Input line voltage RMS between R and S (format: value, F=1)
0x0051	READ_VIN_ST(L2-L3)	0x04	2	Input line voltage RMS between S and T (format: value, F=1)
0x0052	READ_VIN_TR(L3-L1)	0x04	2	Input line voltage RMS between T and R (format: value, F=1)
0x0056	READ_FREQ_R(L1)	0x04	2	Input frequency from R phase (format: value, F=0.1)
0x0057	READ_FREQ_S(L2)	0x04	2	Input frequency from S phase (format: value, F=0.1)
0x0058	READ_FREQ_T(L3)	0x04	2	Input frequency from T phase (format: value, F=0.1)
0x0080	MFR_ID_B0B5	0x03	6	Manufacturer's name
0x0083	MFR_ID_B6B11	0x03	6	Manufacturer's name
0x0086	MFR_MODEL_B0B5	0x03	6	Manufacturer's model name
0x0089	MFR_MODEL_B6B11	0x03	6	Manufacturer's model name
0x008C	MFR_REVISION_B0B5	0x03	6	Firmware revision
0x00B0	CURVE_CC	0x03 · 0x06	2	Constant current setting of charge curve (format: value, F=0.01)
0x00B1	CURVE_CV	0x03 · 0x06	2	Constant voltage setting of charge curve (format: value, F=0.1)
0x00B2	CURVE_FV	0x03 · 0x06	2	Floating voltage setting of charge curve (format: value, F=0.1)
0x00B3	CURVE_TC	0x03 · 0x06	2	Taper current setting of charge curve (format: value, F=0.01)
0x00B4	CURVE_CONFIG	0x03 · 0x06	2	Charging status reporting
0x00B5	CURVE_CC_TIMEOUT	0x03 · 0x06	2	CC charge timeout setting of charging curve (format: value, F=1)
0x00B6	CURVE_CV_TIMEOUT	0x03 · 0x06	2	CV charge timeout setting of charging curve (format: value, F=1)
0x00B7	CURVE_FV_TIMEOUT	0x03 · 0x06	2	FV charge timeout setting of charging curve (format: value, F=1)
0x00B9	BAT_ALM_VOLT	0x03 · 0x06	2	Battery low voltage alarm threshold (format: value, F=0.1)

Register Addresses	Command Name	Supported Function Codes	# of data Bytes	Description
0x00BA	BAT_SHDN_VOLT	0x03、0x06	2	Battery low voltage shutdown threshold (format: value, F=0.1)
0x00BB	BAT_RCHG_VOLT	0x03、0x06	2	Battery recharge voltage threshold (format: value, F=0.1)
0x00BC	BAT_OV_ALM_VOLT	0x03、0x06	2	Battery over-voltage alarm threshold (format: value, F=0.1)
0x0100	INV_OPERATION	0x03、0x06	2	Operation configuration
0x0101	INV_CONFIG	0x03、0x06	2	UPS or Energy-saving mode configuration
0x0102	Output ACV_Set	0x03、0x06	2	Output AC Frequency read value from T phase 110/220series: 1: 100/200 2: 110/220 3: 115/230 4: 120/240
0x0103	Output ACF_Set	0x03、0x06	2	Output AC Frequency Setting 1 : 50Hz 2 : 60Hz
0x0105	READ_ACR_FOUT(L1)	0x04	2	Output AC Frequency read value from R phase (format: value, F=0.1)
0x0106	READ_ACS_FOUT(L2)	0x04	2	Output AC Frequency read value from S phase (format: value, F=0.1)
0x0107	READ_ACT_FOUT(L3)	0x04	2	Output AC Frequency read value from T phase (format: value, F=0.1)
0x0108	READ_ACR_VOUT(L1)	0x04	2	Output AC Voltage read value from R phase (format: value, F=1)
0x0109	READ_ACS_VOUT(L2)	0x04	2	Output AC Voltage read value from S phase (format: value, F=1)
0x010A	READ_ACT_VOUT(L3)	0x04	2	Output AC Voltage read value from T phase (format: value, F=1)
0x010B	READ_OP_LD_PCNT	0x04	2	O/P load percent read value from 0~1000%
0x0114	READ_OPR_VA_HI(L1)	0x04	2	O/P apparent power read value (High) from R phase (format: value, F=1)
0x0115	READ_OPR_VA_LO(L1)	0x04	2	O/P apparent power read value (Low) from R phase (format: value, F=1)
0x0116	READ_OPS_VA_HI(L2)	0x04	2	O/P apparent power read value (High) from S phase (format: value, F=1)
0x0117	READ_OPS_VA_LO(L2)	0x04	2	O/P apparent power read value (Low) from S phase (format: value, F=1)

Register Addresses	Command Name	Supported Function Codes	# of data Bytes	Description
0x0118	READ_OPT_VA_HI	0x04	2	O/P apparent power read value (High) from T phase (format: value, F=1)(L3)
0x0119	READ_OPT_VA_LO	0x04	2	O/P apparent power read value (Low) from T phase (format: value, F=1)(L3)
0x011A	READ_VBAT	0x04	2	Battery voltage read value (format: value, F=0.01)
0x011C	BAT_CAPACITY	0x04	2	Battery percent capacity read value from 0~100
0x012B	READ_ACR_IOUT(L1)	0x04	2	AC output current read value from R phase (format: value, F=1)
0x012C	READ_ACS_IOUT(L2)	0x04	2	AC output current read value from S phase (format: value, F=1)
0x012D	READ_ACT_IOUT(L3)	0x04	2	AC output current read value from T phase (format: value, F=1)
0x1000	OPERATION (All)	0x03、0x06、0x10	2	System on/off control 0x00(OFF)/0x01(ON)
0x1080	Relay1	0x03、0x06、0x10	2	Relay1 setting
0x1081	Relay2	0x03、0x06、0x10	2	Relay2 setting
0x1082	Relay3	0x03、0x06、0x10	2	Relay3 setting
0x1083	Relay4	0x03、0x06、0x10	2	Relay4 setting
0x1084	Digital Output1 (DOUT #1)	0x03、0x06、0x10	2	Digital output 1 setting
0x1085	Digital Output2 (DOUT #2)	0x03、0x06、0x10	2	Digital output 2 setting
0x1086	Digital Output3 (DOUT #3)	0x03、0x06、0x10	2	Digital output 3 setting
0x1087	Digital Output4 (DOUT #4)	0x03、0x06、0x10	2	Digital output 4 setting
0x1088	Digital Output5 (DOUT #5)	0x03、0x06、0x10	2	Digital output 5 setting
0x1090	Relay Status	0x03	2	Status reading of all relays
0x1091	Digital IO Status	0x03	2	Status reading of all digital inputs and outputs

Register Addresses	Command Name	Supported Function Codes	# of data Bytes	Description
0x2000~0x20BF	single machine value #0 ~ single machine value #191	0x65	2*192	Number data from inverter unit #0 ~ #191
0x20D0~0x284F	single machine string #0 ~ single machine string #191	0x65	20*192	String data from inverter unit #0 ~ #191
0x3000~0x4F3F	Event log #1 ~ Event log #8000	0x64	1*8000	Event log #1 ~ Event log #8000

#### Data Conversion:

The conversion of setting and reading values is defined as following:  
 Actual value = Communication reading value × Factor (F value). Among them, Factor needs to refer to the definition of SCALING\_FACTOR in each model list.

EX: Vo\_real (actual DC voltage) = READ\_VOUT × Factor.

If the Factor of READ\_VOUT of a certain model is 0.01, the communication reading value is 0x0960 (hexadecimal) → 2400 (decimal), then VDC\_real = 2400 × 0.01 = 24.00V.

© MFR\_ID\_B0B5 (0x0080) is the first 6 codes of the manufacturer's name (ASCII); MFR\_ID\_B6B11 (0x0083) is the last 6 codes of the manufacturer's name (ASCII)

EX: Manufacturer's name is MEANWELL MFR\_ID\_B0B5 is MEANWE ;  
 MFR\_ID\_B6B11 is LL

MFR_ID_B0B5					
Byte0	Byte1	Byte2	Byte3	Byte4	Byte5
0x4D	0x45	0x41	0x4E	0x57	0x45

MFR_ID_B6B11					
Byte0	Byte1	Byte2	Byte3	Byte4	Byte5
0x4C	0x4C	0x20	0x20	0x20	0x20

© MFR\_MODEL\_B0B5 (0x0086) is the first 6 codes of the manufacturer's model name (ASCII); MFR\_MODEL\_B6B11 (0x0083) is the last 6 codes of the manufacturer's model name (ASCII)  
 EX: Model name is → MFR\_MODEL\_B0B5 is NTN-5K-224 NTN-5K;  
 MFR\_MODEL\_B6B11 is 00-224

MFR_MODEL_B0B5					
Byte0	Byte1	Byte2	Byte3	Byte4	Byte5
0x4E	0x54	0x4E	0x2D	0x35	0x48

MFR_MODEL_B6B11					
Byte6	Byte7	Byte8	Byte9	Byte10	Byte11
0x2D	0x32	0x32	0x34	0x20	0x20

© MFR\_REVISION\_B0B5 (0x008C) is the firmware revision. A range of 0x00 hexadecimal (R00.0)~0xFE (R25.4) represents the firmware version of an MCU; 0xFF represents no MCU existed  
 EX: The controller has three MCUs, the firmware version of the MCU number 1 is version R25.4 (0xFE), the MCU number 2 is version R10.5 (0x69) and the third is version R01.0 (0x0A)

Byte0	Byte1	Byte2	Byte3	Byte4	Byte5
0xFE	0x69	0x0A	0xFF	0xFF	0xFF

© CURVE\_CONFIG(0x00B4) :

	Bit7	Bit6	Bit5	Bit4	Bit3	Bit2	Bit1	Bit0
High byte	---	---	---	---	---	FVTOE	CVTOE	CCTOE
Low byte	---	STGS	---	---	---	---	---	---

Low byte:

Bit 6 **STGS : 2/3 Stage Charge Setting**

0 = 3 stage charge (default, CURVE\_CV and CURVE\_FV)

1 = 2 stage charge (only CURVE\_CV)

High byte:

Bit 0 **CCTOE : Constant Current Stage Timeout Indication Enable**

0 = disable (default)

1 = enabled

Bit 1 **CVTOE : Constant Voltage Stage Timeout Indication Enable**

0 = disable (default)

1 = enabled

Bit 2 **FTTOE : Float Voltage Stage Timeout Indication Enable**

0 = disable (default)

1 = enabled

Note: Unsupported settings displays with "0"

© INV\_OPERATION(0x0100) :

	Bit7	Bit6	Bit5	Bit4	Bit3	Bit2	Bit1	Bit0
High byte	---	---	---	---	---	---	---	---
Low byte	---	---	---	---	GRID_EN	CHG_EN	---	---

Bit 2 CHG\_EN: AC Charger Control

0 = Turn OFF the AC charger when in AC bypass mode

1 = Turn ON the AC charger when in AC bypass mode(Default)

Bit 3 GRID\_EN: Grid-tied Power Feeding Control (for grid-tied models only)

0 = Do NOT feed AC energy from the battery back to the grid (Default)

1 = Feed AC energy from the battery back to the grid when available

Note: Unsupported settings displays with "0"

© INV\_CONFIG(0x0101) :

	Bit7	Bit6	Bit5	Bit4	Bit3	Bit2	Bit1	Bit0
High byte	---	---	---	---	---	---	---	---
Low byte	---	---	---	---	CHG_Prio		INV_Prio	

Low byte:

Bit 0:1 INV\_Prio: Operation mode selection

b00 = UPS Mode (Default)

b01 = Energy- saving Mode

b10 = Solar power first (For models with solar input only)

b11 = Reserved

Bit 2:3 CHG\_PROP: Operation mode selection for the built-in charger

b00 = Utility power first (Default)

b01 = Solar power first (For models with solar input only)

b10 = Reserved

b11 = Reserved

Note: Unsupported settings displays with "0"

© Relay1~ Relay4(0x1080 - 0x1084) Setting:

	Bit7	Bit6	Bit5	Bit4	Bit3	Bit2	Bit1	Bit0
High byte	---	---	---	---	Source			
Low byte	Trigger				Delay			

Low byte:

Bit 0 - 3 Delay

Please refer to the table below for detailed parameter setting.

Bit 4 - 7 Trigger

Please refer to the table below for detailed parameter setting.

High byte:

Bit 0 - 3 Source

Please refer to the table below for detailed parameter setting

Source	Trigger	Delay
0: INV Alarm	11: Any 12: OVP 13: OTP 14: OLP 150 15: INV Fault	0: Immed. 1: 1 Sec 2: 5 Sec 3: 10 Sec 4: 30 Sec 5: 1 Min 6: 2 Min
2: INV / PSU	7: On 8: Off	7: 3 Min 8: 4 Min
3: DI CH1	9: High 10: Low	9: 5 Min
4: DI CH2		10: 6 Min
5: DI CH3		11: 7 Min
6: DI CH4		12: 8 Min
7: DI CH5		13: 9 Min 14: 10 Min

© Digital Output 1~5(0x1084~0x1088) Setting:

	Bit7	Bit6	Bit5	Bit4	Bit3	Bit2	Bit1	Bit0
High byte	Source				Trigger			
Low byte	Action				Delay			

Low byte:

Bit 0 - 3 Delay

Please refer to the table below for detailed parameter setting.

Bit 4 - 7 Action

Please refer to the table below for detailed parameter setting.

High byte:

Bit 0 - 3 Trigger

Please refer to the table below for detailed parameter setting.

Bit 4 - 7 Source

Please refer to the table below for detailed parameter setting.

Source	Trigger	Action	Delay
0: INV Alarm	11: Any 12: OVP 13: OTP 14: OLP 150 15: INV Fault	0: High 1: Low	0: Immed. 1: 1 Sec 2: 5 Sec 3: 10 Sec 4: 30 Sec 5: 1 Min 6: 2 Min 7: 3 Min 8: 4 Min 9: 5 Min 10: 6 Min 11: 7 Min 12: 8 Min 13: 9 Min 14: 10 Min
2: INV / PSU	7: On 8: Off		
3: DI CH1	9: High		
4: DI CH2	10: Low		
5: DI CH3			
6: DI CH4			
7: DI CH5			

© Relay Status(0x0100) Definition:

	Bit7	Bit6	Bit5	Bit4	Bit3	Bit2	Bit1	Bit0
High byte	---	---	---	---	---	---	---	---
Low byte	---	---	---	---	Relay4	Relay3	Relay2	Relay1

Bit 0 **Relay 1** : Relay 1 status

0 = Relay OPEN

1 = Relay SHORT

.....

Bit 4 **Relay 4** : Relay 4 status

0 = Relay OPEN

1 = Relay SHORT

© Digital IO Status(0x1091) Definition:

	Bit7	Bit6	Bit5	Bit4	Bit3	Bit2	Bit1	Bit0
High byte	---	---	---	DI5	DI4	DI3	DI2	DI1
Low byte	---	---	---	DO5	DO4	DO3	DO2	DO1

Low byte:

Bit 0 **D01** : Digital Output 1 status

0 = LOW

1 = High

.....

Bit 4 **D04** : Digital Output 4 status

0 = LOW

1 = High

High byte:

Bit 0 **DI1** : Digital Input 1 status

0 = LOW

1 = High

.....

Bit 4 **DI5** : Digital Input 5 status

0 = LOW

1 = High

- Single machine value #0 ~ single machine value #191 (0x20000~x20BF):  
Each number data return contains 2 bytes in hexadecimal.  
For further details, please refer to the sample in section 5.3.6.5.

Types	Command	Description	Unit
0x00: INV	0x00	Load Current	0.01A
	0x01	Load Power	1VA
	0x02	Charging Current	0.01A
	0x03	Battery Voltage	0.1V
	0x04	Temperature	0.1°C
	0x05	FAN Speed 1	1RPM
	0x06	FAN Speed 2	1RPM

- Single machine value #0 ~ single machine value #191 (0x20000~x20BF):  
Each number data return contains 2 bytes in hexadecimal.  
For further details, please refer to the sample in section 5.3.6.5.

Types	Command	Description	Unit
0x00: INV	0x80	Model	ASCII
	0x81	Version	ASCII
	0x82	Status	ASCII

- Event Log(0x6000~0x07F3F) Data structure Definition  
Event data store as ASCII strings. Maximum bytes for a No. resistor is 62 bytes, data length is dependent on its actual content. If no data that exists, it will display 0x00.

Byte 0 ----- ByteN							
Max10 Bytes	1Byte	Max20 Bytes	1Byte	Max10 Bytes	1Byte	Max 18 Bytes	1Byte
Device	,	Event	,	date	space	time	\n

- ※ N means data length, maximum length is 27 bytes.
- ※ Byte 0 sends first

Device (Max 10 Bytes)	Event (Max 20 Bytes)	Date (Max 10 Bytes)	Time (Max 8 Bytes)
System	1 · EEPROM Error 2 · EEPROM Error Remove 3 · Model Error 4 · Model Error Remove 5 · Comm. Error 6 · Comm. Err Remove	20YY/MM/DD	HH:MM:SS
INV_00 ~ INV_31	1 · OVP 2 · OVP Remove 3 · OLP 4 · OLP Remove 5 · Short 6 · Short Remove 7 · OTP 8 · OTP Remove 9 · AC Fail 10 · AC Fail Remove 11 · FAN Lock 12 · FAN Lock Remove		

Please refer to 5.3.7.3 for an event log query.

### 5.3.6 Communication Examples

The following provides examples of request and response for each function code of the Modbus TCP protocol.

#### 5.3.6.1 Read Holding Registers (FC=0x03)

The request message specifies the starting register and quantity of registers to be read.

For example: Client requests the content of analog output holding registers 0x008C (MFR\_REVISION\_B0B5) from the server

Request:

0x00020000000601	0x03	0x008C	0x0001
------------------	------	--------	--------

0x00020000000601: MBAP Header

0x03: Function code 3 (Read Analog Output Holding Registers)

0x008C: The Data Address of the first register requested.

0x0003: The total number of registers requested (Read only one register from 0x008C)

Response:

0x00020000000901	0x03	0x06	0x0A0A0AFFFFFF
------------------	------	------	----------------

0x00020000000901: MBAP Header  
 0x03: Function code 3 (Read Analog Output Holding Registers)  
 0x06: The number of data bytes to follow (6 bytes)  
 0x0A 0A 0A FF FF FF: means that the firmware version of the MCU number1 is R01.0, R01.0 for the MCU number 2 and R01.0 for the MCU number 3.

### 5.3.6.2 Read Input Register (FC=0x04)

The request message specifies the starting register and quantity of registers to be read.

For example: Client requests the content of analog input register 0x0108 (READ\_ACR\_VOUT) from the server

Request:

0x00020000000601	0x04	0x0108	0x0001
------------------	------	--------	--------

0x00020000000601: MBAP Header  
 0x04: Function code 4 (Read Analog Input Registers)  
 0x0108: The Data Address of the first register requested  
 0x0001: The total number of registers requested (Read only 1 registers from 0x0108)

Response:

0x00020000000501	0x04	0x02	0x00E6
------------------	------	------	--------

0x00020000000501: MBAP Header  
 0x04: Function code 4 (Read Analog Input Register)  
 0x02: The number of data bytes to follow (2 bytes)  
 0x00E6: 0x00E6 → 230x1 = 230Vac

### 5.3.6.3 Write Single Register (FC=0x06)

The request message specifies the register reference to be written.

For example: Client sets the output of all inverters to 200V by 0x0102 (Output ACV\_set) command.

Request:

0x00020000000601	0x06	0x0102	0x0001
------------------	------	--------	--------

0x00020000000601: MBAP Header  
 0x06: Function code 6 (Preset Single Register)  
 0x0102: The Data Address of the register  
 0x0001: The value to write

Response:

The normal response is an echo of the query, returned after the register contents have been written.

### 5.3.6.4 Write Multiple Register (FC=0x10)

The request message specifies the multi-register references to be written.

For example: Client writes settings to the Relay1 -Relay2 (0x1080 - 0x1081)

Relay1: INV Alarm;Any;Immed

Relay2: DI CH1;Hihg;1 Sec

Request:

0x00020000000D01	0x10	0x1080	0x0002	0x04	0x00B0	0x0491
------------------	------	--------	--------	------	--------	--------

0x00020000000D01: MBAP Header  
 0x10: Function code 10 (Write Multiple Register)  
 0x1080: The Data Address of the first register  
 0x0002: The total number of registers (write 2 registers from 0x1080 to 0x1081)  
 0x04: The number of data bytes to follow (4 bytes)  
 0x00B0: The value writes to 0x1080. Set all the Relay 1 at INV; Any; Immed  
 0x0491: The value writes to 0x1081. Set all the Relay 1 at DI CH2; High; 1 Sec

### 5.3.6.5 Read Single machine status (FC = 0x65)

The request message specifies the starting register, quantity of registers, type and command to be read.

For example: Client requests Load Current from single machine# 0 to single machine# 15.

Request:

0x00020000000601	0x65	0x2000	0x0010	0x00	0x00
------------------	------	--------	--------	------	------

0x00020000000601: MBAP Header

0x65: Function code 65 (Read Single machine status)

0x2000: The Data Address of the first register

0x0010: The total number of registers requested

0x00: type INV

0x00: Load Current

0x00020000000601	0x65	0x20	0x12	0x34	0x22	0x35	...	0x22	0x65
	Byte count	INV 0 Load Current	INV 1 Load Current	...	INV 15 Load Current				

Byte Count: The byte count field specifies the quantity of complete bytes of data. There are 36 bytes of data to follow.

Each piece of information consists of 2 bytes, resulting in a total of 16 pieces of information, that is INV0 Load Current = 0x1234, INV1 Load Current = 0x2235 ..... NV15 Load Current = 0x2265.

Nv0 Load Current: 0x1234 → 4660 x 0.01A = 46.6A

INV1 Load Current: 0x2235 → 8757 x 0.01A = 87.57A

Nv15 Load Current: 0x2265 → 8805 x 0.01A = 88.05A

### 5.3.6.6 Read Array Log (FC=0x64)

The request message specifies the starting register and quantity of registers to be read.

For example: Client requests the content of analog output holding registers 0x3000 (Event log#1) from the server

Request:

0x00020000000601	0x64	0x3000	0x0001
------------------	------	--------	--------

0x00020000000601: MBAP Header

0x64: Function code 64 (Read Array Log)

0x3000: The Data Address of the first register requested

0x0001: The total number of registers requested (Read only 1 registers from 0x6000)

Response:

Read Array Log is a self-definition of Mean Well, response data frame is as the following

MBAP Header	Function code	Byte Count	Register Value
7 bytes	0x64	N*2	2*N bytes

Byte Count: The byte count field specifies the quantity of complete bytes of data

Register Value: The contents of event log. The data needs to be converted into ASCII codes before reading

Example:

0x0020000004101	0x64	0x3E	49 4E 56 5F 31 34 2C 42 41 54 20 4F 56 50 2C 32 31 30 30 2F 30 32 2F 32 32 20 32 30 3A 30 30 3A 31 35 0A 00
-----------------	------	------	---

0x0020000004101: MBAP Header

0x64: Function code 64 (Read Array Lo)

0x3E: The number of data bytes to follow (62 bytes)

0x49~00(62 bytes in total): It means "INV\_14,BAT OVP,2100/02/22 20:00:15" after converting into ASCII codes "

## 6.Maintenance

### 6.1 Firmware update instruction

Firmware updates are infrequent but sometimes may be necessary for older devices due to product compatibility. If you feel the need, please click the link below to download the latest firmware version. You can perform a firmware update by following the instruction below.

LINK: <https://www.meanwell.com.tw/Upload/PDF/CMU2/CMU2-SOP-T.pdf>

Please note that a SD Card is needed and inserted to the CMU2E for a firmware update process.

- Update – online:

- ① Access the web page and then click Upload FW button to upload the firmware files to the CMU2E.

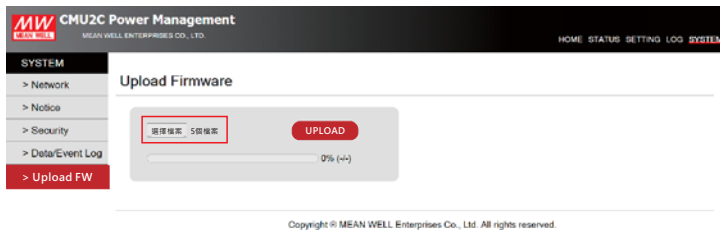

- ② After selecting the correct firmware files, click UPLOAD button to upload the firmware to the latest version.

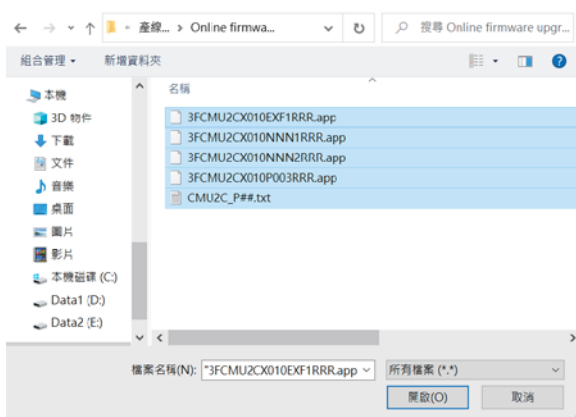

- ③ The latest firmware version will be displayed on the Utility page of the CMU2E unit when the firmware files are uploaded successfully.



- ④ Tap the Update buttons on the screen to schedule a firmware update. The firmware update will complete automatically after rebooting the CMU2E unit.

• Update – offline:

- ① Remove the SD card from the CMU2E unit and then save the downloaded firmware to the Firmware Upgrade file in the SD card.
- ② The latest firmware version will be displayed on the Utility page of the CMU2E unit after inserting the SD card.

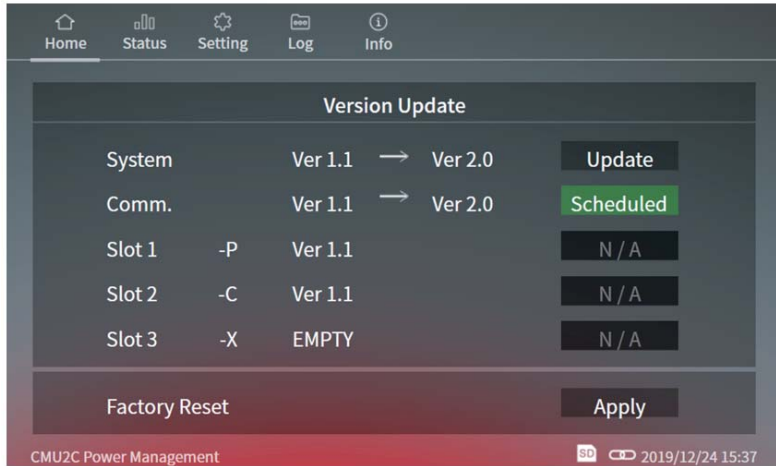

- ③ Tap the Update buttons on the screen to schedule a firmware update. The firmware update will complete automatically after rebooting the CMU2E unit.

## 7.Warranty

This product provides five years warranty under normal usage. Do not replace parts or any form of modification to the product in order to keep the warranty effectively.

※ MEAN WELL possesses the right to adjust the content of this manual. Please refer to the latest version of our manual on our website.  
<https://www.meanwell.com>



明緯企業股份有限公司

MEAN WELL ENTERPRISES CO., LTD.

248 新北市五股區五權三路28號

No.28, Wuquan 3rd Rd., Wugu Dist., New Taipei City 248, Taiwan

Tel: 886-2-2299-6100 Fax: 886-2-2299-6200

<http://www.meanwell.com> E-mail: [info@meanwell.com](mailto:info@meanwell.com)