



BIC-5K Series

Installation manual



Charger

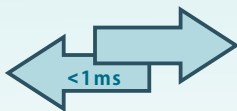

Inverter

Bidirectional Power Supply

• High efficiency • Lightweight • Intelligent

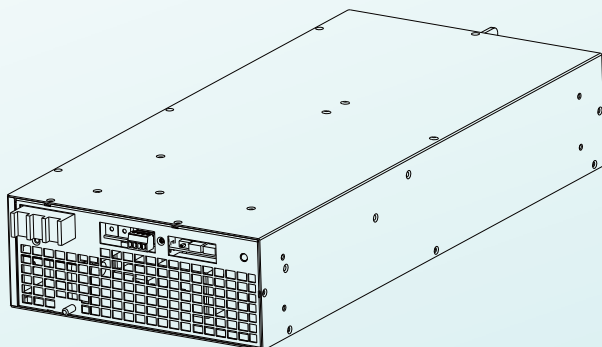

The BIC-5K series is a 5KW bidirectional power supply featuring AC-DC↔DC-AC conversion with energy recovery functionality. This product adopts a fully digitalized design, characterized by high efficiency, intelligence, compact size, and comprehensive safety certifications. It is commonly used in applications such as battery factory grading/forming testing equipment, home energy storage systems, kinetic energy recovery systems, and distributed grids (V2G). The BIC-5K series is a high-reliability green energy power solution that supports energy saving and carbon reduction.

Contents

1.Safety Guidelines	1
2.Introduction	2
2.1 Model Encoding	2
2.2 Features	2
2.3 Specification	3
2.4 Derating Curve	5
2.5 Mechanical Specification	6
3.Installation & Wiring	9
3.1 Precautions	9
3.2 Installation Procedures	9
3.3 DC Cable Size Selection	11
4.User Interface	12
4.1 AC Panel	12
4.2 DC Panel	13
4.3 LED Indicator	13
4.4 Pin Assignment of CRL	15
4.5 Pin Assignment of COMM	16
4.6 Pin Assignment of PAR1,PAR2	17
4.7 Communication Address/ID Assignment	19
5.Explanation of Operation	20
5.1 BIC Mode	21
5.1.1 Description of Bidirectional Operation	22
5.1.2 Bi-directional Auto-detect Mode	22
5.1.3 Bi-directional Battery Mode	24
5.1.3.1 DIR_CTRL Command (digital)	25
5.1.3.2 C/D Control (analog)	26
5.1.3.3 Notes on Bi-directional Battery Mode	26
5.2 Grid-tied Mode	28
5.2.1 Basic Parameters (users)	28
5.2.2 Advanced Parameters (DSO)	28
5.2.2.1 National Grid-tie Standard Selection	29
5.2.2.2 Grid Connection and Disconnection	30

Contents

5.2.2.3 Active Power and Reactive Operating Range and Level	31
5.2.2.4 Active Power Setting	31
5.2.2.5 Reactive Power Setting	33
5.2.2.6 Power Derating Control	39
5.2.2.7 Over-voltage/Under-voltage Ride Through Setting (OVRT & UVRT)	40
5.2.2.8 LFSM Setting	43
5.2.2.9 LFSM Pref Setting	46
5.2.2.10 ROCOF(Rate-of-change-of-frequency) Protection	46
5.2.2.11 Network and System protection (NS Protection)	47
5.2.2.12 EEPROM Storage	49
5.2.2.13 Password for the Grid Connection Parameters	49
5.2.3 Special condition behavior: Grid-tied Mode + Charger Mode	50
5.3 Charger Mode	51
5.3.1 2 Stage Charging	52
5.3.2 3 Stage Charging	54
5.4 Inrush Current Limiting	56
5.5 Power Factor Correction (PFC)	56
5.6 Fan Speed control	56
5.7 Fault Signal	56
5.8 $\overline{DC-OK}$ Signal	56
5.9 Remote Control	57
5.10 Current Sharing	58
5.10.1 Parallel Operation with 3-phase 4-wire System	59
5.11 Factory Resetting	60
6.Communication Protocol	61
6.1 CANBus Protocol	61
6.1.1 CANBus Specification	61
6.1.2 Message ID Definition	62
6.1.3 CANBus command list	62

Contents

6.1.4 CAN Bus Communication Examples	92
6.1.4.1 Sending command	92
6.1.4.2 Reading data or status	93
6.1.4.3 POUT_USER_CMD(0x0150) Settngins for User	96
6.1.4.4 Event Logs	94
6.1.4.5 Password Seting for the Grid Connection Parameters for DSO	96
6.1.5 CAN Bus Practical Operation	98
6.2 Modbus Protocol	100
6.2.1 Communication Timing	100
6.2.2 Modbus Frame Encapsulation	101
6.2.3 Additional Address Definition	101
6.2.4 Function Code Description	101
6.2.5 Data Field and Command Lists	102
6.2.6 Modbus Communication Examples	133
6.2.6.1 Function code	133
6.2.6.2 POUT_USER_CMD(0x0150) Settngins for User	134
6.2.6.3 Event Logs	135
6.2.6.4 Password Seting for the Grid Connection Parameters for DSO	137
6.2.7 Modbus Practical Operation	139
6.3 Value Range and Tolerance	142
7.Protections and Trouble shooting	153
7.1 Protections	153
7.1.1 Over Temperature Protection (OTP) and Alarm	153
7.1.2 AC Fail Protection	153
7.2 Troubleshooting	154
8.Warranty	155
9.Environmental declaration information	156

1.Safety Guidelines

- Risk of electrical shock and energy hazard, all failure should be examined by a qualified technician. Please do not remove the case from the bidirectional power supply by yourself.
- Please refrain from situating the bidirectional power supply in damp environments or in close proximity to water sources.
- Please do not install the bidirectional power supply in places with high ambient temperature or under direct sunlight.
- The AC voltage range is 180 – 305Vac (47 – 63Hz), please do not connect the bidirectional power supply to AC grid out of the range.
- Make sure the air flow from the fan is not obstructed at both sides (front and back) of the unit. (Please allow at least 15cm of space).
- Please do not stack any object on the bidirectional power supply.
- The safety protection level of this supply is class I. The "Frame Ground" (⏚) of the unit must be well connected to PE (Protective Earth).

2.Introduction

2.1 Model Encoding

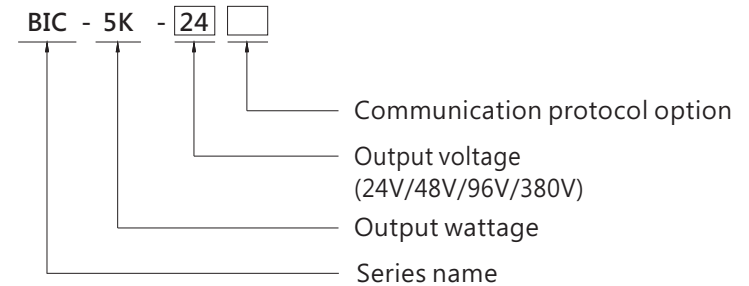

Type	Communication Protocol	Note
Blank	CANBus protocol	In Stock
MOD	MODBus protocol	In Stock

2.2 Features

- Combining AC → DC and DC → AC bidirection power, 5KW full-power operation in both directions
- Ultra-fast bidirectional time of 1ms(AC ⇌ DC)
- Global certificates in multi-fields (ITE 62368-1, Energy converter 62477-1, AC Grid system 50549-1)
- 180~305Vac(277Vac available)
- High efficiency up to 93.5%
- THD <3% in both conversion mode
- Parallel operation up to 30KW(5+1 unit)
- Support CANBus or MODBus-RTU(RS-485) protocol communication
- Complete protections: Anti-islanding protection, AC fail protection, DC OVP, OLP, OCP, OTP
- Over voltage category III (OVC III)
- -30°C ~ +70°C wide operating temperature
- FAN noise < 43~54dB
- Support 3Ø with multiple units configuration
- Conformal coating
- 5 years warranty

2.3 Specification

SPECIFICATION		BIC-5K-24 □	BIC-5K-48 □	BIC-5K-96 □	BIC-5K-380 □
		□=Blank, MOD (standard model in stock)			
OUTPUT					
DC VOLTAGE	24V	48V	96V	380V	
RATED CURRENT	208A	104A	52A	13.22A	
RATED POWER	4992W	4992W	4992W	5025W	
FULL POWER VOLTAGE RANGE	24 ~ 33V	48 ~ 66V	96 ~ 112V	335 ~ 430V	
RIPPLE & NOISE (max.)	Note.2 350mVp-p	600mVp-p	900mVp-p	2.8Vp-p	
VOLTAGE RANGE	19 ~ 33V	38 ~ 66V	76 ~ 112V	280 ~ 430V	
CURRENT RANGE	0 ~ 208A	0 ~ 104A	0 ~ 52A	0 ~ 15A	
VOLTAGE TOLERANCE	Note.3 ±2.0%				
LINE REGULATION	±1.0%				
LOAD REGULATION	±1.0%				
SETUP, RISE TIME	8000ms, 150ms/230Vac at full load				
INPUT					
AC VOLTAGE RANGE	180 ~ 305Vac				
FREQUENCY RANGE	47 ~ 63Hz				
POWER FACTOR (Typ.)	≥ 0.99/230Vac at full load				
EFFICIENCY (Typ.)	Note.4 91%	92.5%	93%	93%	
AC CURRENT (Typ.)	27A/230Vac				
INRUSH CURRENT (Typ.)	120A/230Vac				
LEAKAGE CURRENT (Peak)	7.07mA/305Vac				
TOTAL HARMONIC DISTORTION	<3%(@load=100%/230Vac)				
DC to AC Direction					
INPUT POWER (Max.)	5665W	5550W	5550W	5500W	
FULL POWER VOLTAGE RANGE	24 ~ 33V	48 ~ 66V	96 ~ 112V	335 ~ 430V	
DC VOLTAGE RANGE	19 ~ 33V	38 ~ 66V	76 ~ 112V	280 ~ 430V	
MAX. INPUT CURRENT	232A	114A	57A	16A	
OUTPUT					
RATED OUTPUT POWER (Typ.)	5000W				
VOLTAGE RANGE	180 ~ 305Vac determined by AC main (277Vac available)				
FREQUENCY RANGE	47 ~ 63Hz determined by AC main				
AC CURRENT (Typ.)	22.5A/230Vac				
POWER FACTOR (Typ.)	0.99/230Vac at full load				
EFFICIENCY (Typ.)	Note.4 91%	93%	93%	93.5%	
TOTAL HARMONIC DISTORTION	<3%(@load=100%/230Vac)				
PROTECTION					
OVER LOAD	105 ~ 115% rated output power AC to DC Constant current limiting, shut down DC O/P voltage 5 sec. after DC O/P voltage is down low, re-power on to recover DC to AC Not accurate with constant power design				
SHORT CIRCUIT	Shut down O/P current, re-power on to recover				
OVER VOLTAGE	34 ~ 35V	68 ~ 70V	115 ~ 121V	435 ~ 450V	
OVER TEMPERATURE	Protection type : Shut down O/P voltage, re-power on to recover				
ISLANDING PROTECTION	Shut down O/P voltage, recovers automatically after temperature goes down				
ISLANDING PROTECTION	Shut down AC O/P voltage, re-power on to recover				
FUNCTION					
BIDIRECTION SWITCH TIME (Typ.)	1ms	1ms	3ms	1ms	
PARALLEL	Up to 30KW(5+1) units, Please refer to the Function Manual				
CANBUS or MODBUS	Communication provides function such as control, setting and monitoring				
REMOTE ON-OFF CONTROL	By electrical signal or dry contact Short: Power ON Open: Power OFF Please refer to the Function Manual infollowing				
FAN SPEED CONTROL (Typ.)	Note.6 10% load with Ta=25°C	54dB	43dB	43dB	43dB
	70% load with Ta=25°C	54dB	44dB	44dB	44dB

ENVIRONMENT			
WORKING TEMP.	-30 ~ +70°C (Refer to "Derating Curve")		
WORKING HUMIDITY	20 ~ 90% RH non-condensing		
STORAGE TEMP., HUMIDITY	-40 ~ +85°C, 10 ~ 95% RH non-condensing		
TEMP. COEFFICIENT	±0.03%/°C (0 ~ 40°C)		
VIBRATION	10 ~ 500Hz, 3G 10min./1cycle, 60min. each along X, Y, Z axes		
SAFETY & EMC			
SAFETY STANDARDS	CB IEC62368-1/IEC62477-1 UL UL62368-1, CAN/CSA C22.2 No.62368-1 TUV BS EN/EN62368-1, BS EN/EN62477-1, BS EN/EN50549-1 EAC TP TC 004 approved		
OVER VOLTAGE CATEGORY	IEC/EN/UL 62368-1 (OVCI, altitude up to 2000m) IEC/EN 62477-1 (OVCI, altitude up to 2000m)		
WITHSTAND VOLTAGE	Note.7 I/P-O/P:6KVdc I/P-FG:4KVdc O/P-FG:4Vdc		
ISOLATION RESISTANCE	Note.7 I/P-O/P, I/P-FG, O/P-FG:100M Ohms / 500Vdc / 25°C / 70% RH		
EMC EMISSION	BS EN/EN55032, BS EN/EN61000-6-4		
	Parameter	Standard	Test Level / Note
	Conducted	BS EN/EN55032 (CISPR32)	Class A
	Radiated	BS EN/EN55032 (CISPR32)	Class A
	Harmonic Current	BS EN/EN61000-3-12	Class A
Voltage Flicker	BS EN/EN61000-3-11	-----	
EMC IMMUNITY	BS EN/EN55035, BS EN/EN61000-6-2		
	Parameter	Standard	Test Level / Note
	ESD	BS EN/EN61000-4-2	Level 3, 8KV air ; Level 2, 4KV contact
	Radiated	BS EN/EN61000-4-3	Level 3
	EFT / Burst	BS EN/EN61000-4-4	Level 3
	Surge	BS EN/EN61000-4-5	2KV/Line-Line 4KV/Line-Earth
	Conducted	BS EN/EN61000-4-6	Level 3
	Magnetic Field	BS EN/EN61000-4-8	Level 4
Voltage Dips and Interruptions	BS EN/EN61000-4-34	>95% dip 0.5 periods, 30% dip 25 periods, >95% interruptions 250 periods	
OTHERS			
MTBF	209.4K hrs min. Telcordia SR-332 (Bellcore) ; 17.8K hrs min. MIL-HDBK-217F (25°C)		
DIMENSION	460*211*83.5mm (L*W*H)		
PACKING	12Kg; 1pcs/ 12Kg/ 1.25CUFT		
NOTE			
1. All parameters NOT specially mentioned are measured at 230VAC input, rated load and 25°C of ambient temperature.			
2. Ripple & noise are measured at 20MHz of bandwidth by using a 12" twisted pair-wire terminated with a 0.1uF & 47uF parallel capacitor.			
3. Tolerance : includes set up tolerance, line regulation and load regulation.			
4. Efficiency is tested 75% load, linear load at 230Vac input voltage and 24V/48V/96V/380Vdc output voltage			
5. The power supply is considered as an independent unit, but the final equipment still need to re-confirm that the whole system complies with the EMC directives.			
6. FAN noise test set up according to ISO-7779.			
7. During withstand voltage and isolation resistance testing, the screw "A" shall be temporarily removed, and shall be installed back after the testing.			
8. The Regulatory Compliance Mark (RCM) is applied on a voluntary basis. The equipment meets the relevant IEC or AS/NZS standards, or AS/NZS 3820 where applicable. The use of the RCM mark complies with AS/NZS 4417.1.			
※ Product Liability Disclaimer : For detailed information, please refer to https://www.meanwell.com/serviceDisclaimer.aspx			

2.4 Derating curve

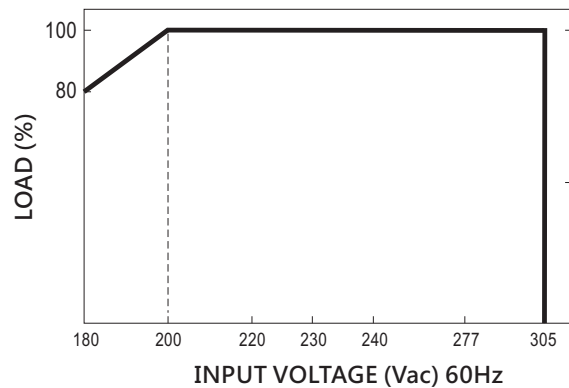
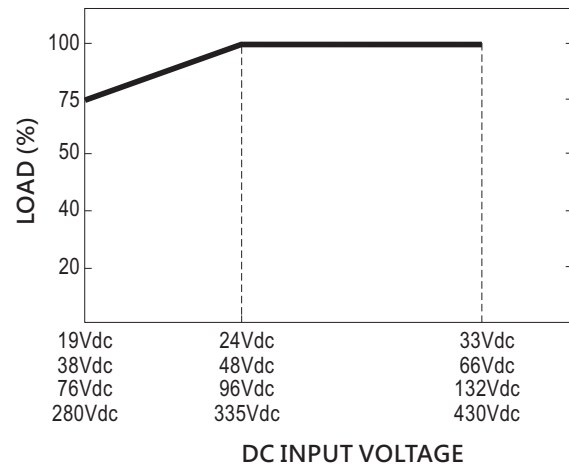
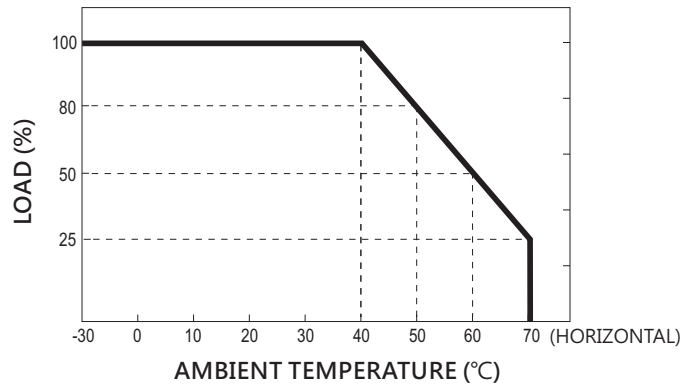

2.5 Mechanical specification

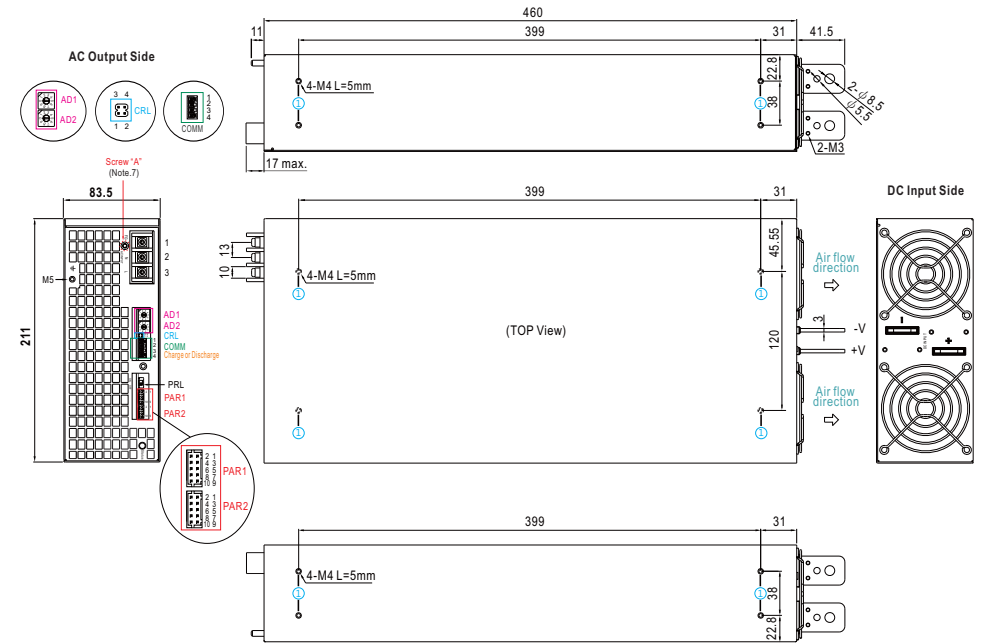

※ Mounting Instruction

Hole No.	Recommended Screw Size	MAX. Penetration Depth L	Recommended mounting torque
①	M4	5mm	7~10Kgf-cm

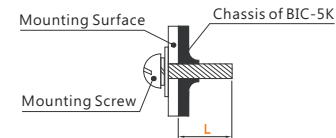

※ Terminal Pin No. Assignment

Pin No.	Assignment	Terminal	Maximum mounting torque
1	FG		18Kgf-cm
2	AC/N		
3	AC/L		

Included Accessory List

		Item	Quantity																				
①	Remote control short wire	<p>UL1007 26AWG (1-3 short) 15</p> <p>HRS DF11-10DP-2DS or equivalent</p> <table border="1"> <tr> <td>1</td><td>2</td><td>3</td><td>4</td><td>5</td><td>6</td><td>7</td><td>8</td><td>9</td><td>10</td> </tr> <tr> <td>Green</td><td>NC</td><td>Green</td><td>NC</td><td>NC</td><td>NC</td><td>NC</td><td>NC</td><td>NC</td><td>NC</td> </tr> </table>	1	2	3	4	5	6	7	8	9	10	Green	NC	Green	NC	NC	NC	NC	NC	NC	NC	1
1	2	3	4	5	6	7	8	9	10														
Green	NC	Green	NC	NC	NC	NC	NC	NC	NC														
②	Parallel function mating wire	<p>UL1061 28AWG 250 210 20</p> <p>HRS DF11-10DP-2DS or equivalent</p> <table border="1"> <tr> <td>1</td><td>2</td><td>3</td><td>4</td><td>5</td><td>6</td><td>7</td><td>8</td><td>9</td><td>10</td> </tr> <tr> <td>Black</td><td>Brown</td><td>Red</td><td>Orange</td><td>Yellow</td><td>Green</td><td>Blue</td><td>Purple</td><td>Gray</td><td>White</td> </tr> </table>	1	2	3	4	5	6	7	8	9	10	Black	Brown	Red	Orange	Yellow	Green	Blue	Purple	Gray	White	1
1	2	3	4	5	6	7	8	9	10														
Black	Brown	Red	Orange	Yellow	Green	Blue	Purple	Gray	White														
③	Communication connector		1																				
④	Jumper of termination resistor		1																				

		Item	Quantity
⑤	Terminal protectors for the DC end	<p>52 mm</p> <p>40.8 mm</p> <p>39.8 mm</p>	Each for 1
⑥	Terminal protectors' screws		4
⑦	Screws, nuts and washers for DC connection	<p>M8</p> <p>M5</p>	Each for 2

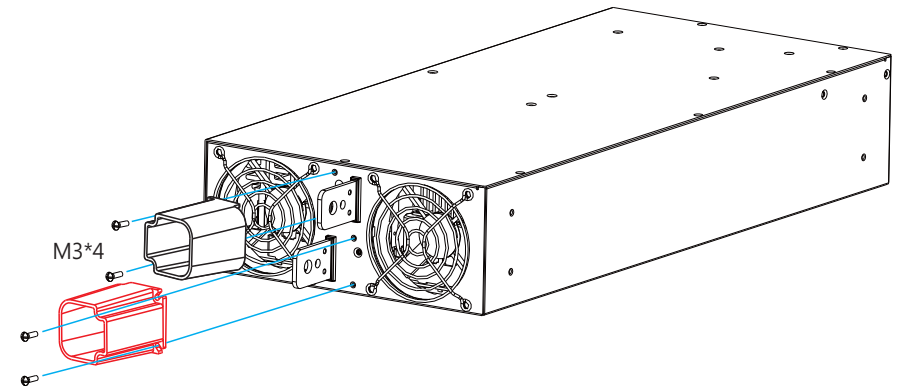

3.Installation & Wiring

3.1 Precautions

- The unit should be mounted on a flat surface or holding rack with suitable strength.
- In order to ensure the lifespan of the unit, you should refrain from operating the unit in environments with high dust or moisture.
- BIC-5K is designed with built-in DC fans. Please make sure that the ventilation is not blocked. We recommend that there should be no barriers within 15cm of the ventilation slits, as shown below.

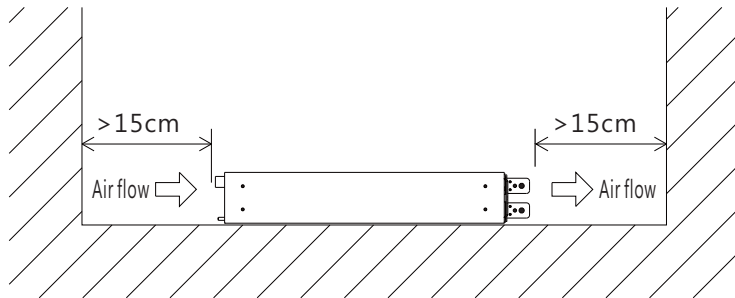
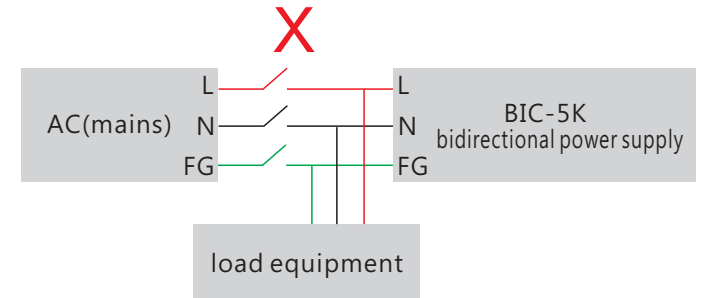
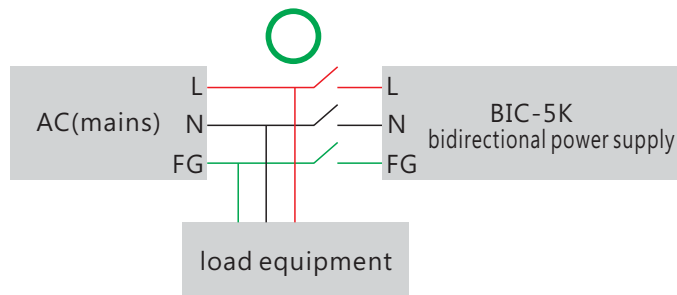

Figure 3-1 Arrangement suggestion

3.2 Installation Procedures

- AC End
To avoid AC voltage surges, it is recommended that the BIC-5K and the load equipment do not share the same circuit breaker.



NOTE : The bidirectional power supply is single-phase input/output. Please pay attention to the wiring when connecting the supply to a three-phase system.

- DC End
 - ① Choose the right and suitable cable size for connection between the BIC-5K and the loads or batteries. Please refer to 3.3 DC Cable Size Selection.
 - ② Connect the DC positive polarity of the supply to the positive of the loads/batteries and connect the DC negative polarity of the supply to the negative of the loads/batteries. Make sure there is no reverse polarity or short-circuit on the connection.

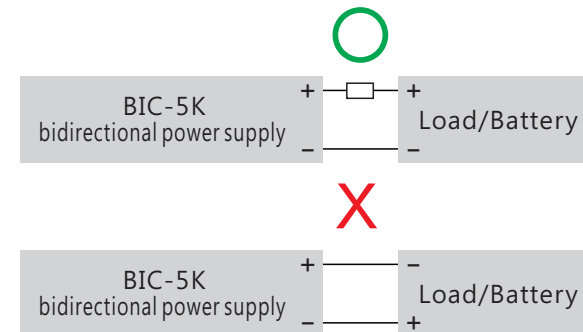

NOTE : To enhance system safety, it is recommended to install a circuit breaker or a fuse on the battery's positive terminal.

3.3 DC Cable Size Selection

Wire connections should be as short as possible and less than 1 meter is highly recommended. Make sure that suitable wires are chosen based on safety requirement and rating of current. Small cross section will result in lower efficiency, less output power and the wires may also become overheated and cause danger. For selection, please refer to table 3-1.

Table 3-1 Wire recommendations

AWG	Cross-section Area(mm ²)	Maximum DC current (A)
8	6	40A
6	10	60A
4	16	80A
2	25	100A
1	35	125A
0	50	160A
000	75	190A
0000	95	230A

4. User Interface

4.1 AC Panel

- Ⓐ **AC terminals :**
M4 screws are used; Recommended cable size: 10 AWG ; Recommended torque: 18kgf-cm.
- Ⓑ **AD1,AD2 :**
Serve as the device address setting for communication purposes. Please refer to Section 4.7 for details.
- Ⓒ **CRL :**
Termination resistor, used to stabilize the Modbus / CAN bus communication and eliminate signals reflection.
- Ⓓ **COMM :**
The Modbus-RTU / CAN bus communication port.
- Ⓔ **PRL :**
Used to stabilize signals for multiple BIC-5K units connected in parallel. Please refer to Section 5.10 Current Sharing for detailed usage.
- Ⓕ **PAR1,PAR2 :**
For the usage of remote on/off and parallel functions, please refer to Section 4.6.
- Ⓖ **LED indicator :**
Indicate the current operational status of the bidirectional power supply. Please refer to section 4.3.

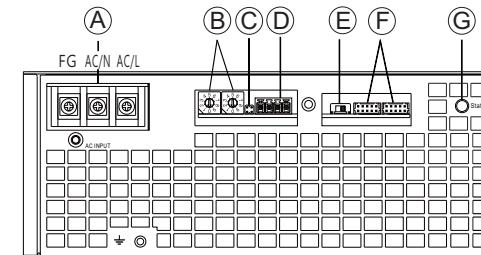

4.2 DC Panel

Ⓐ Ventilation slits :

To ensure proper operation and preserve the lifespan of the power supply, please ensure suitable ventilation is provided.

Ⓑ DC terminals (+),(-):

M8 screws are used; Please refer to Section 3.3 for cable suggestion.

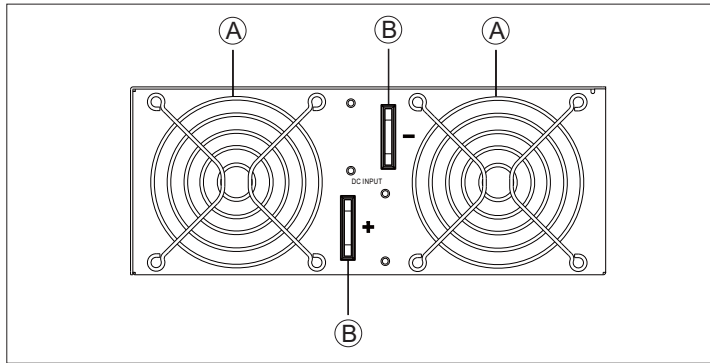

4.3 LED Indicator

The LED indicator is controlled by the MCU. The MCU will change color and pattern of the indicator according to its operation status. The indicator lights in constant green when the supply is in AC/DC mode; The indicator's flashing in green when the supply is in DC/AC mode; The indicator turns red when the supply is in abnormal conditions or protection mode.

BIC Mode :

LED	Description
● Green	AC to DC Direction, functions as regular power supply
☀ Green	DC to AC Direction, functions as grid inverter
● Red	Abnormal status (Over temperature protection, Overload protection, Fan fail.)
● Orange	Standby during starup

- Light
- ☀ Flash

50549 Mode and Charger Mode

LED	Description
● Green	50549 Mode : Power absorption ; Charger Mode : Float or Battery full
☀ Green	DC to AC Direction, functions as grid inverter
● Red	Abnormal status (Over temperature protection, Overload protection, Fan fail.)
● Orange	Standby during startup
☀ Orange	Charger mode:Charging

- Light
- ☀ Flash

Protection Alarm Signal

Output of alarm	Description
☀ Red : Blink	High Ambient temperature alarm ^{*1}
☀ Red : 1 Blink/Pause	Overload(OLP)
☀ Red : 2 Blink/Pause	Over voltage(OVP)
☀ Red : 3 Blink/Pause	Over temperature / Under temperature(OTP/UTP)
☀ Red : 4 Blink/Pause	Fan fail
☀ Red : 5 Blink/Pause	Others ^{*2}

Note : *1. The high ambient temperature alarm is for notification purposes only and will not shut down the output.

*2. Others include protection status SCP、AC UVP and EEPROM error.

4.4 Pin Assignment of CRL

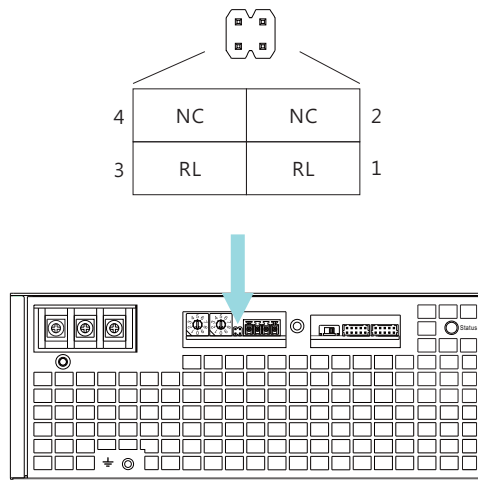

4.5 Pin Assignment of COMM

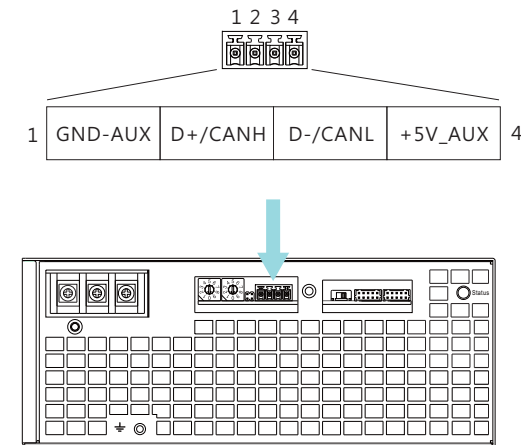

Connect Pin No. Assignment:

Pin No.	Function	Description
1,3	RL	Pin 1 and Pin 3 are designated for enabling the built-in termination resistor on the communication bus. This is achieved by short-circuiting the two pins or by installing a jumper.
2,4	NC	Pin 2 and Pin 4 are used to place the jumper when the unit is not the terminations.

Note : The CRL acts as a termination resistor that is used to eliminate signal reflection and improve signal stability.
For an example of usage, please refer to Section 6.1.5 CAN Bus Practical Operation/6.2.7 Modbus Practical Operation.

Connect Pin No. Assignment : EC381V-04P or equivalent

Pin No.	Function	Description
1	GND_AUX	Auxiliary voltage output GND.
2	D+/CANH	For MODBus model: Data line used in MODBus interface.(Note)
		For CANBus model: Data line used in CANBus interface.(Note)
3	D-/CANL	For MODBus model: Data line used in MODBus interface.(Note)
		For CANBus model: Data line used in CANBus interface.(Note)
4	+5V_AUX	Auxiliary voltage output, 4.5~5.5V, referenced to GND_AUX (pin1)

Note : Isolated signal, referenced to GND_AUX.

4.6 Pin Assignment of PAR1, PAR2

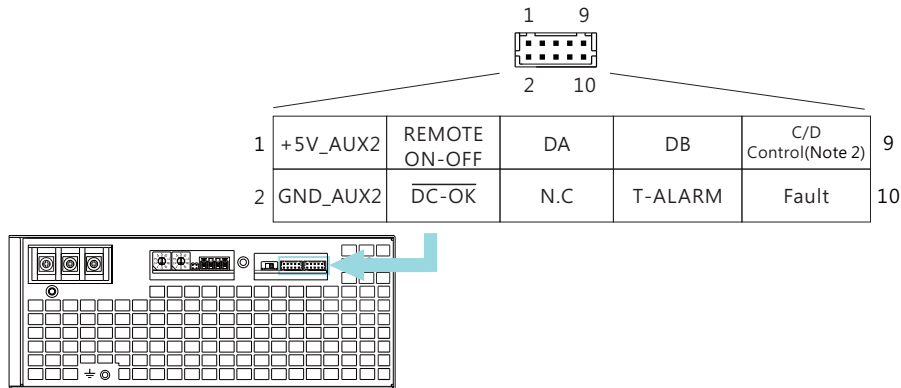

Connect Pin No. Assignment : HRS DF11-10DP-2DS or equivalent

Pin No.	Function	Description
1	+5V_AUX2	Auxiliary voltage output, 4.5~5.5V, referenced to GND_AUX2 (pin2). (Only for REMOTE ON-OFF)
2	GND_AUX2	Auxiliary voltage output GND_AUX2 (pin2).
3	REMOTE ON-OFF	The unit can turn the output ON/OFF by dry contact between Remote ON/OFF and +5_AUX2.(Note 1) SHORT : Power ON ; OPEN : Power OFF
4	DC-OK (Note.3)	High (4.5 ~ 5.5V) : When the $V_{out} \leq 80\% \pm 5\%$. Low (-0.5 ~ 0.5V) : When $V_{out} \geq 80\% \pm 5\%$. The maximum sourcing current is 4mA and only for output. (Note.1)
5	DA	Data line used for parallel control.
6	N.C	Unused
7	DB	Data line used for parallel control.
8	T-ALARM	High (4.5 ~ 5.5V) : When the internal temperature exceeds the limit of temperature alarm, or when any of the fans fails. Low (-0.5 ~ 0.5V) : When the internal temperature is normal, and when fans work normally. The maximum sourcing current is 4mA and only for output(Note.1)

Pin No.	Function	Description
9	C/D Control(Note 2)	High (4.5 ~ 5.5V) : Battery Charging mode (Note 2) Low (0 ~ 0.5V) : Battery Discharging mode (Note 2)
10	Fault	High (4.5 ~ 5.5V) : When the $V_{ac} \leq 165V_{rms}$, OLP, SCP, OTP, OVP, AC Fail, fan lock, islanding protection. Low (-0.5 ~ 0.5V) : When $V_{ac} \geq 175V_{rms}$ and when power supply work normally. The maximum sourcing current is 4mA and only for output. (Note.1)

Note 1 : Isolated signal, referenced to GND_AUX2.

Note 2 : Only for battery mode use.

Note 3 : DC OK signal is not supported in Charger mode / Grid mode.

4.7 Communication Address/ID Assignment

Each BIC-5K unit should have their unique and own device address to communicate over the bus. AD1 and AD2 allow users to designate an address/ID for the Modbus/ CAN bus communication interface (with maximum of 64 addresses).

Please refer to the table below for detailed settings.

NOTE : For CAN bus/ Modbus command settings, please refer to chapter 6.

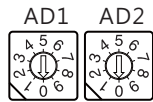

Address/ID	Switch position	
	AD1	AD2
0	0	0
1	0	1
2	0	2
3	0	3
4	0	4
5	0	5
6	0	6
7	0	7
8	0	8
9	0	9
10	1	0
11	1	1
12	1	2
13	1	3
14	1	4
15	1	5
16	1	6
17	1	7
18	1	8
19	1	9
20	2	0
21	2	1
22	2	2
23	2	3
24	2	4
25	2	5
26	2	6
27	2	7
28	2	8
29	2	9
30	3	0
31	3	1

Address/ID	Switch position	
	AD1	AD2
32	3	2
33	3	3
34	3	4
35	3	5
36	3	6
37	3	7
38	3	8
39	3	9
40	4	0
41	4	1
42	4	2
43	4	3
44	4	4
45	4	5
46	4	6
47	4	7
48	4	8
49	4	9
50	5	0
51	5	1
52	5	2
53	5	3
54	5	4
55	5	5
56	5	6
57	5	7
58	5	8
59	5	9
60	6	0
61	6	1
62	6	2
63	6	3

5. Explanation of Operation

The BIC-5K has three main operation modes: BIC Mode, Grid-tied Mode, and Charger Mode.

- (1) BIC Mode : This is the bidirectional power supply mode, supporting both Bi-directional Auto-detect Mode and Bi-directional Battery Mode.
- (2) Grid-tied Mode : This mode is designed specifically to comply with EN 50549-1, the European standard that specifies the technical requirements for the connection of generating plants. All parameters can be adjusted through the communication interfaces according to the requirements of local power stations.
- (3) Charger Mode : Supports 2-stage or 3-stage charging profiles and customizable charging curves, such as constant current (CC), constant voltage (CV), etc.
- (4) Grid-tied Mode+ Charger Mode : Grid-tied Mode can combine with Charger Mode to charge the batteries when the battery voltage is low.
It returns back to Grid-tied Mode when the battery is fully charged.

These main operation modes can be configured via INV_OPERATION(0x0100) command.

Mode	CHG_EN (Low byte: bit 2)	GRID_EN (Low byte: bit 3)
BIC Mode	0	0
Grid-tied Mode	0	1
Charger Mode	1	0
Grid-tied Mode + Charger Mode	1	1

NOTE : A device reboot is required when switching between BIC Mode and Grid-tied Mode.

5.1 BIC Mode

BIC-5K possesses AC to DC and DC to AC two way conversion functions. The conversion direction can be automatically detected and controlled by BIC-5K's internal firmware or manually switched by users according to different application requirements. Before entering detailed function explanation. Please refer to following definitions.

Mode Selection: Set low byte bit2 (CHG_EN) and bit3 (GRID_END) at "logic low" in the INV_OPERATION(0x0100) command.

AC to DC (Energy absorbing and charging/ power supplying) :

The BIC-5K converts AC energy from the grid into DC energy for the battery or the loads. The operation principle is the same as an ordinary power supply or a charger.



DC to AC (Energy recycling and discharging) :

Opposite to the AC to DC conversion, the BIC-5K converts DC energy from the battery or loads into AC energy, then feeding back to the grid. AC output synchronization range is 180Vac~305Vac/47Hz~63Hz, the bidirectional power supply can work normally as long as the AC grid is within the range.



NOTE: The BIC-5K has a built-in program that detects the AC voltage range for different regions. For example, in a 230 Vac system, if the AC voltage rises to 277 Vac, the device will trigger AC OVP and shut down. It will resume normal operation once the AC voltage returns to the normal range.

5.1.1 Description of Bidirectional Operation

The output range of the BIC-5K series covers DC: 19V – 430V; AC: 180 – 305Vac / 47-63Hz, which can be used to applications with various voltage requirements, such as battery test equipment. To cope with different application occasions, there are two modes for selection, bi-directional auto-detect mode and bi-directional battery mode.

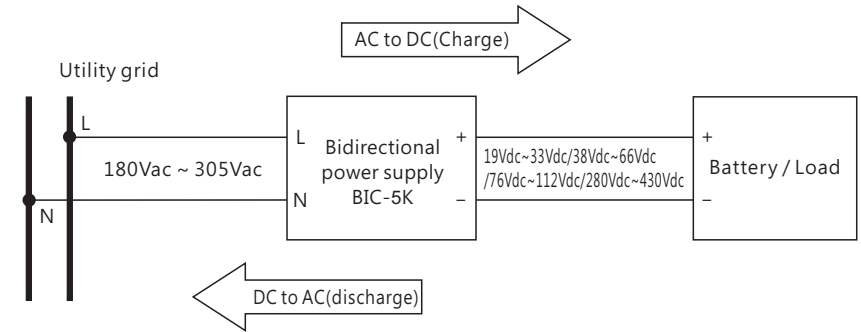

5.1.2 Bi-directional Auto-detect Mode

This is the default factory setting in BIC Mode, AC to DC or DC to AC conversion is controlled by BIC-5K automatically according to operation mechanism below.

- "Target voltage" is the DC voltage setting of the bidirectional supply, when the DC end voltage is different from the "target voltage", the internal firmware will switch between two conversion functions of AC to DC or DC to AC. "Target voltage" is adjustable by the communication interfaces.
- When the "target voltage" is higher than the battery voltage or application equipment voltage, the BIC-5K operates in AC to DC conversion.
- When the "target voltage" is lower than the battery voltage or application equipment voltage, the BIC-5K operates in DC to AC conversion.

NOTE: During this mode, AC to DC or DC to AC conversion is judged by the internal firmware. Active control signal (e.g. C/D control) will not take effect in this mode.

Condition	Conversion
$V_{Target} > V_{DC}$	AC to DC
$V_{Target} < V_{DC}$	DC to AC

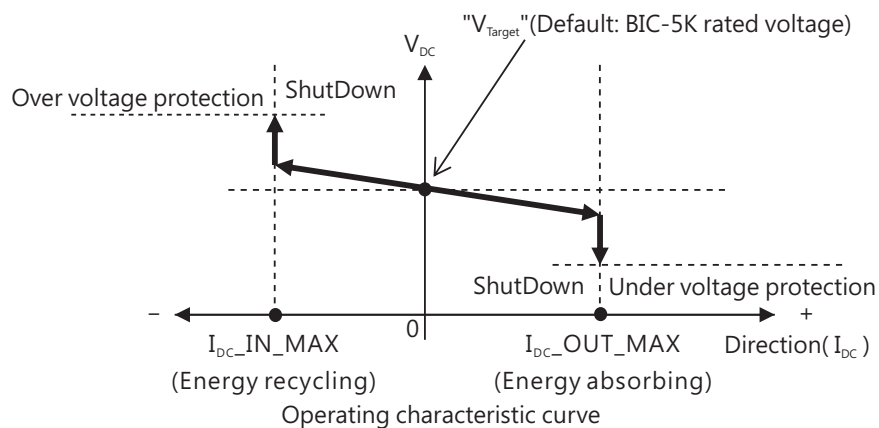

The supported commands are in the table:

Command Code	Command Name	Description	Default
0x0020	VOUT_SET	DC voltage setting	24V: 24V 48V: 48V 96V: 96V 380V: 380V
0x0030	IOUT_SET	Charge current setting	24V: 228.8A 48V: 114.4A 96V: 57.2A 380V: 16.5A
0x0142	IOUT_SET_REV	Discharge current setting	24V: -232A 48V: -114A 96V: -57A 380V: -16A

5.1.3 Bi-directional Battery Mode

To activate the mode, please follow instructions below:

1. Set command SYSTEM_CONFIG (CAN:0x00C2 ; MOD:0x00C4) at 0x0003 → Activate CAN bus/Modbus communication mode.
2. Set command BIDIR_CONFIG (0x0143) at 0x0001 → Set at Bi-directional Battery Mode.

3. Repower on the supply to activate the battery mode.
NOTE: For detailed information on the communication interfaces, please refer to 6. Protocol

After Bi-directional Battery Mode is activated, users can switch the device between AC to DC or DC to AC conversion by DIR_CTRL command (digital) or C/D control (analog). Please refer to 5.1.3.1 command (digital) and 5.1.3.2 C/D control (analog)

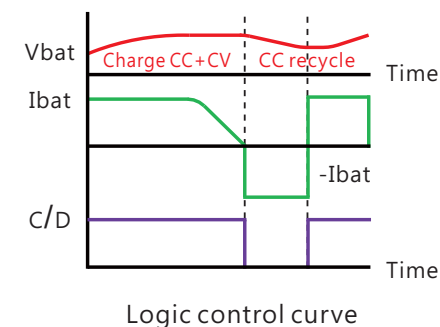

The supported commands are in the table:

Command Code	Command Name	Description	Default
0x0020	VOUT_SET	Charge voltage setting	24V: 25.2V 48V: 50.4V 96V: 96V 380V: 400V
0x0030	IOUT_SET	Charge current setting	24V: 228.8A 48V: 114.4A 96V: 57.2A 380V: 16.5A
0x0140	DIR_CTRL	A/D or D/A conversion control	00h(A/D)

Command Code	Command Name	Description	Default
0x0141	VOUT_SET_REV	Discharge voltage setting	24V: 19V 48V: 38V 96V: 76V 380V: 280V
0x0142	IOUT_SET_REV	Discharge current setting	24V: -232A 48V: -114A 96V: -57A 380V: -16A
0x0143	BIDIR_CONFIG	Bidirectional mode configuration	00h(auto-detect)

5.1.3.1 DIR_CTRL Command (digital)

The users can set the supply in AC to DC (charging) or DC to AC (discharging) conversion directly through command DIR_CTRL (0x0140). Command VOUT_SET (0x0020) and IOUT_SET (0x0030) are used to adjust values of charge voltage and charge current in AC to DC conversion. Command VOUT_SET_REV (0x0141) and IOUT_SET_REV (0x0142) are used to adjust values of discharging voltage and discharging current in DC to AC conversion.

Command	Conversion
DIR_CTRL = 00h	AC to DC(charging)
DIR_CTRL = 01h	DC to AC(discharging)

5.1.3.2 C/D Control (analog)

The users also can control AC to DC (charging) or DC to AC (discharging) conversion via analog signals. To activate the mode, please follow the steps below:

1. Set command BIDIR_CONFIG(0x0143) at "1" → Activate battery mode.
2. Set desired target voltage through VOUT_SET(0x0020)/VOUT_SET_REV(0x0141) and AC/DC and DC/AC current through IOUT_SET(0x0030)/IOUT_SET_REV(0x0142).
AC/DC parameters: VOUT_SET(0x0020)/ IOUT_SET(0x0030)
DC/AC parameters: VOUT_SET_REV(0x0141)/IOUT_SET_REV(0x0142)

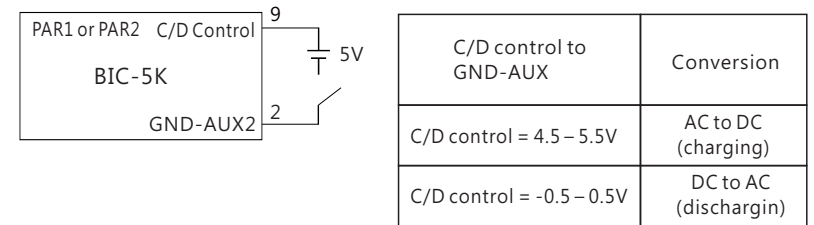

NOTE: Please make sure CAN_CTRL(Bit 0) of SYSTEM_CONFIG (CAN:0x00C2 ; MOD:0x00C4) is set at "0" in order not to interfere in C/D control.

5.1.3.3 Notes on Bi-directional Battery Mode

In Bi-directional Battery Mode, although users can determine direction of the conversions on their demand, however if the setting voltage does not match the actual DC end voltage, AC to DC (charging) or DC to AC (discharging) conversion may not work as expected. Here are examples that will cause conversion errors.

1. During AC to DC conversion (C/D control = High or DIR_CTRL = 00h), if battery voltage is higher than the value of command VOUT_SET (charge voltage), the BIC-5K will perform DC to AC conversion instead, but limiting discharge current at 2% of rated current. If you want to ensure AC to DC conversion working properly, please make sure value of command VOUT_SET is higher than the battery voltage.
2. During DC to AC conversion (C/D control = Low or DIR_CTRL = 01h), if battery voltage is lower than the value of command VOUT_SET_REV, the BIC-5K will perform AC to DC conversion instead, but then limiting charge current at 2% of rated current. To ensure DC to AC conversion working properly, please make sure value of command VOUT_SET_REV is lower than the battery voltage.

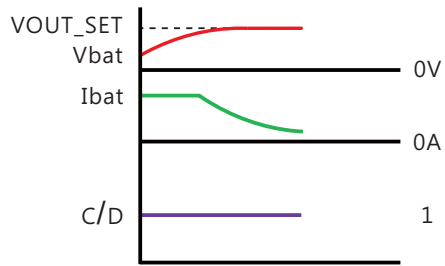

VOUT_SET higher than Vbat and C/D=1

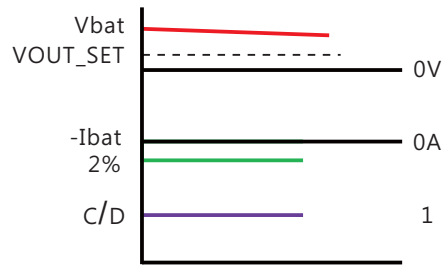

VOUT_SET lower than Vbat and C/D=1

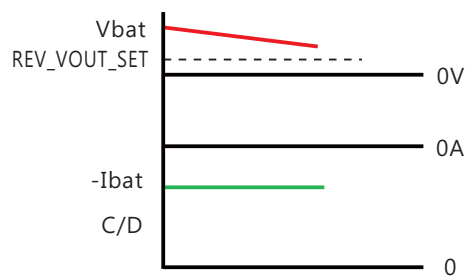

VOUT_SET_REV lower than Vbat and C/D=0

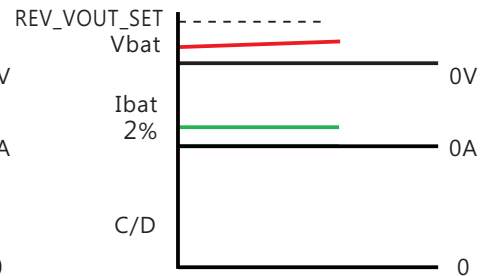

VOUT_SET_REV higher than Vbat and C/D=0

5.2 Grid-tied Mode

For the grid-tie inverter to feed-in electricity to local utility grid, local regulation has to be followed. This device is designed for meeting EN 50549 regulations. Further it has the possibility to set up different parameters in order to meet national requirements. To use this device for this purpose please ensure local regulation is followed, and device parameters should be properly set before putting into force.

In this section, Basic Parameters (users) and Advanced Parameters (DSO) are introduced to support proper integration of the device.

Mode Selection: Set low byte bit3 (GRID_END) at "logic high" in the INV_OPERATION(0x0100) command.

NOTE: In this mode, most parameters are determined by grid requirements. Any configuration or modification must be approved by the local DSO or the grid company before making any adjustments.

5.2.1 Basic Parameters (users)

The POUT_USER_CMD (0x0150) command allows users to set the device to either generate or absorb active power ($\pm P_n$). This enables flexible energy-management strategies, such as delivering power during peak hours or charging the battery from the grid during off-peak hours.

- POUT_USER_CMD > 0: discharges power from the battery to the grid.
- POUT_USER_CMD < 0: charges the battery from the grid.

To use this function, the device must first be unlocked by the SETTING_UNLOCK (0x00CF) command. For detailed unlocking procedures, please refer to section 6.1.4.3 for CAN bus or section 6.2.6.2 for Modbus.

NOTE: The maximum value of POUT_USER_CMD is limited by P_SET (0x02EC).

5.2.2 Advanced Parameters (DSO)

The advanced parameters must be configured according to the grid standards of the country or region where the device is installed. Once a safety standard is selected, its default parameters are loaded automatically. Any further adjustments should only be made by qualified personnel.

5.2.2.1 National Grid-tie Standard Selection

Users can set safety standard according to different countries and grid tied standards via the COUNTRY_SET(0x02E5) command. There are 12 standards for selection.

COUNTRY_SET (0x02E5)	Standard	Country/Region
0	EN50549-1	50549 default
1	VDE-AR-N 4105	Germany
2	NEN-EN 50549-1	Netherlands
3	C10/11, edition 2.3	Belgium
4	CEI 0-21:2022-03	Italy
5	RD 647:2020 NTS Version 2.1	Spain
6	G98/2:2025-03 G99/2:2025-03	UK
7	NF EN 50549-1	France
8	TEKNISK FORSKRIFT 3.3.1 – REVISION 6 – KRAV TIL ENERGILAGERANL/-EG: 2025-03	Denmark(DK1)
9	TEKNISK FORSKRIFT 3.3.1 – REVISION 6 – KRAV TIL ENERGILAGERANL/-EG: 2025-03	Denmark(DK2)
10	RENBLAD 342: Version: 2.0 (06.2020) (Base on NEK EN 50549-1)	Norway
11	EIFS 2018:2 (Refer ALP form Appendix 1)	Sweden
12	VJV 2018 (Base on SFS-EN 50549-1:2019)	Finland
13	CNS 15382	Taiwan (no supported)

NOTE: At present, only EN 50549-1 certification has been obtained. For other standards, please contact your MEAN WELL distributor or MEAN WELL representative for assistance.

5.2.2.2 Grid Connection and Disconnection

When the device starts up, it verifies the grid connection parameters to ensure that the grid voltage is within the specified limits. The startup process then follows the defined observation time and ramp-up rate in the table below for grid connection.

Reconnection: The device reconnects to the grid after a disconnection caused by an abnormal grid voltage or a remote on/off event is resolved.

Disconnection: Grid reconnection is inhibited when the device enters any self-protection conditions, including low battery voltage or over-temperature protection.

Command Code	Command Name	Description	Default (EN50549-1)
0x02D2	CONNECT_UPPER_VOLT	Upper voltage threshold	110%Un
0x02D3	CONNECT_LOWER_VOLT	Lower voltage threshold	85%Un
0x02D4	CONNECT_UPPER_FREQ	Upper frequency threshold	50.1Hz
0x02D5	CONNECT_LOWER_FREQ	Lower frequency threshold	47.5Hz
0x02D6	CONNECT_DLY_TIME	Observation time	60s
0x02D7	CONNECT_P_RATE	The ramp-rate for connecton	65535%Pn/min
0x02D8	RECONNECT_P_RATE	The ramp-rate for reconnecton	10%/min

- NOTE: 1. In Grid-tied Mode, ensure that Remote Control is set to ON and the GRID_TIE_REMOTE (0x02D1) command is enabled to allow grid connection.
2. The default configuration for Grid-tied Mode is 230 V / 50 Hz. If the input voltage or frequency goes beyond the specified range in the table above, the unit will enter an AC fail state. For operation at other voltage or frequency levels, adjust the range settings accordingly.

5.2.2.3 Active Power and Reactive Operating Range and Level

The BIC-5K allows configuration of reactive power. With a rated apparent power of 5000 VA, it can achieve a power factor (PF) of 0.9, either leading or lagging. When PF = 1, the available active power (P_n) is 5000 W.

When PF = 0.9, the maximum active power is $5000 \times 0.9 = 4500$ W, and the corresponding reactive power is $\pm 5000 \times \sqrt{1 - 0.9^2} = \pm 2180$ VA. The device also supports bidirectional power control, with a four-quadrant operating range as illustrated below.

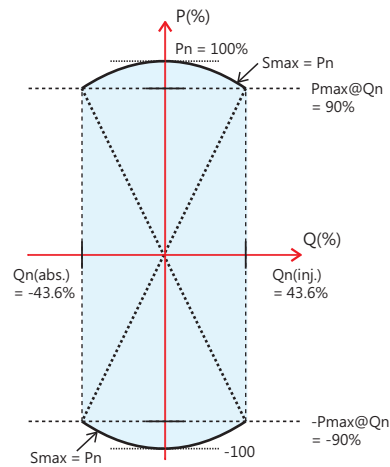

5.2.2.4 Active Power Setting

Users can configure the active power-related parameters through the following communication commands.

Command Code	Command Name	Description	Default (EN50549-1)
0x02E8	CTRL_MODE	Control mode	PU_EN = disable
0x02E9	P_SET_RATE	The ramp-rate for active power	30%/min
0x02EA	P_TAU	The time constant For P(U)	$\tau = 3$ sec

Command Code	Command Name	Description	Default (EN50549-1)
0x02EC	P_SET	Maximum active power output setting	100%Pn
0x03A0	P_V_CURVE_P1	P ₁ on the P(U) Curve	100%Pn
0x03A1	P_V_CURVE_V1	V ₁ on the P(U) Curve	110%Un
0x03A2	P_V_CURVE_P2	P ₂ on the P(U) Curve	100%Pn
0x03A3	P_V_CURVE_V2	V ₂ on the P(U) Curve	110%Un
0x03A4	P_V_CURVE_P3	P ₃ on the P(U) Curve	0%Pn
0x03A5	P_V_CURVE_V3	V ₃ on the P(U) Curve	115%Un
0x03A6	P_V_CURVE_P4	P ₄ on the P(U) Curve	0%Pn
0x03A7	P_V_CURVE_V4	V ₄ on the P(U) Curve	115%Un

※ P_SET value of 100% indicates that the power output is equal to the rated power defined by W_MAX_RTG (0x029D).

※ P(U) Settings: Voltages must satisfy $V_4 > V_3 > V_2 > V_1$.

※ Un is the nominal voltage of the grid system.

For example: If Un is 230Vac, then 110%Un = 253Vac.

CTRL_MODE.PU_EN = 0, (P(U) disabled):

The output power to the grid is limited solely by P_SET (0x02EC). If P_SET is configured below the device's maximum feed-in power, the output follows P_SET, and the ramp rate is determined by P_SET_RATE (0x02E9).

CTRL_MODE.PU_EN = 1, (P(U) enabled):

Except for the maximum active power limited by P_SET, the active power output follows the PV curve shown below, which can be modified by the commands of 0x03A0–0x03A7. Additionally, the power output response is controlled by P_TAU (0x02EA). For example, with $\tau = 3$ s, the output reaches approximately 90% of the target value within 9 seconds.

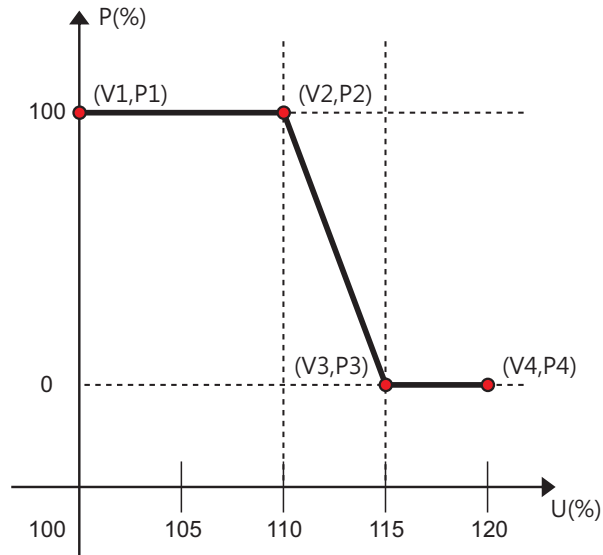

5.2.2.5 Reactive Power Setting

Reactive power setting can be configured through the Q_CTRL_MODE bits in the CTRL_MODE (0x02E8) command, which provides five selectable modes:

- (1) Q Setpoint Mode
- (2) Q(U) Mode
- (3) Q(P) Mode
- (4) Cos(φ) Setpoint Mode (default)
- (5) Cos(φ)(P) Mode

The dynamic response of all the above modes is determined by Q_TAU, which functions the same way as P_TAU.

5.2.2.5.1 Q Setpoint Mode:

Command Code	Command Name	Description	Default (EN50549-1)
0x02E8	CTRL_MODE	Control mode	Q_Ctrl_mode = Q_setpoint
0x02EB	Q_TAU	The time constant for reactive power setting	$\tau = 3\text{sec}$

Command Code	Command Name	Description	Default (EN50549-1)
0x02ED	Q_SET	Maximum reactive power output setting	0%Qn

In Q Setpoint Mode, reactive power is controlled by Q_SET (0x02ED), with the response rate determined by Q_TAU (0x02EB). For instance, if Q_TAU = 3 s, the output achieves about 90% of the target reactive power in approximately 9 seconds.

5.2.2.5.2 Q(U) Mode:

Command Code	Command Name	Description	Default (EN50549-1)
0x02E8	CTRL_MODE	Control mode	Q_Ctrl_mode = Q_(U)
0x02EB	Q_TAU	The time constant for reactive power setting	$\tau = 3\text{sec}$
0x035D	Q_V_MIN_COS	Minimum power factor limitation for Q(U) mode	PF=0
0x035E	Q_V_LOCKIN_P	Lock in power for Q(U) mode	0%Pn(disable)
0x035F	Q_V_LOCKOUT_P	Lock in power for Q(U) mode	0%Pn(disable)
0x0360	Q_V_CURVE_Q1	Q ₁ on the Q(U) Curve	100%Qn
0x0361	Q_V_CURVE_V1	V ₁ on the Q(U) Curve	93%Un
0x0362	Q_V_CURVE_Q2	Q ₂ on the Q(U) Curve	0%Qn
0x0363	Q_V_CURVE_V2	V ₂ on the Q(U) Curve	94%Un
0x0364	Q_V_CURVE_Q3	Q ₃ on the Q(U) Curve	0%Qn
0x0365	Q_V_CURVE_V3	V ₃ on the Q(U) Curve	106%Un
0x0366	Q_V_CURVE_Q4	Q ₄ on the Q(U) Curve	-100%Qn
0x0367	Q_V_CURVE_V4	V ₄ on the Q(U) Curve	108%Un

- ※ The 100% reactive power value for injection and absorption corresponds to VAR_MAX_INJ_RTG (0x02A3) and VAR_MAX_ABS_RTG (0x02A4), respectively.

※ Q(U) settings: voltage values must satisfy V4 > V3 > V2 > V1.

The Q(U) curve defines how reactive power varies with grid voltage, using registers V1, Q1 ~ V4, Q4 (0x0360~0x0367). The device determines the Qcmd based on the measured grid voltage. The ramp-rate follows Q_TAU(0x02EB). For example, when Q_TAU = 3 seconds, the device reaches approximately 90% of the target reactive power within 9 seconds (three time constants).

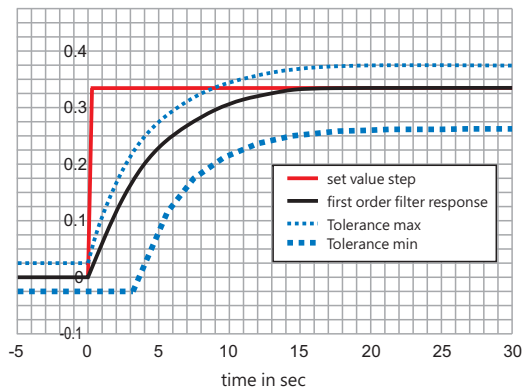

Q(U) Curve :

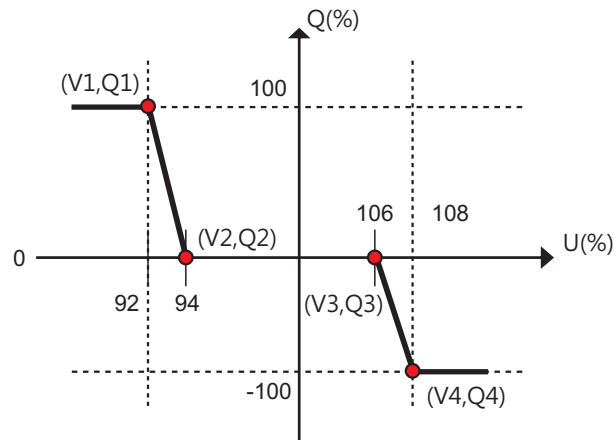

CosMin Setting: When this function is enabled, the active power is controlled by P_SET .

$$Q < \sqrt{\frac{P_{SET}^2 (1 - \cos Min^2)}{\cos Min^2}} \cdot \text{ensuring that } \frac{P_{SET}^2}{P_{SET}^2 + Q_{SET}^2} > \cos Min \text{ setting}$$

P Lock-in / Lock-out Setting:

- When active power P > P Lock-in, the Q(U) mode is activated.
- When active power P < P Lock-out, the Q(U) mode is deactivated.

5.2.2.5.3 Q(P) Mode:

Command Code	Command Name	Description	Default (EN50549-1)
0x02E8	CTRL_MODE	Control mode	Q_Ctrl_mode = Q(P)
0x02EB	Q_TAU	The time constant for reactive power setting	τ=3sec
0x02EF	PF_P_LOCKIN_V	Lock in voltage for Q(P) mode	disable
0x02F0	PF_P_LOCKOUT_V	lock out voltage for Q(P) mode	disable
0x0327	Q_P_CURVE_Q1	Q1 on the Q(P) Curve	100%Qn
0x0328	Q_P_CURVE_P1	P1 on the Q(P) Curve	15%Pn
0x0329	Q_P_CURVE_Q2	Q2 on the Q(P) Curve	0%Qn
0x032A	Q_P_CURVE_P2	P2 on the Q(P) Curve	20%Pn
0x032B	Q_P_CURVE_Q3	Q3 on the Q(P) Curve	0%Qn
0x032C	Q_P_CURVE_P3	P3 on the Q(P) Curve	80%Pn
0x032D	Q_P_CURVE_Q4	Q4 on the Q(P) Curve	-100%Qn
0x032E	Q_P_CURVE_P4	P4 on the Q(P) Curve	90%Pn

- ※ The 100% reactive power value for injection and absorption corresponds to VAR_MAX_INJ_RTG (0x02A3) and VAR_MAX_ABS_RTG (0x02A4), respectively.

※ Q(P) settings: voltage values must satisfy P4 > P3 > P2 > P1.

The Q(P) curve defines how reactive power varies with active power, using registers P1, Q1 ~ P4, Q4 (0x0327~0x032E). The device determines the based on the grid-connected active power. The ramp-rate follows Q_TAU(0x02EB). For example, when Q_TAU = 3 seconds, the device reaches approximately 90% of the target reactive power within 9 seconds (three time constants).

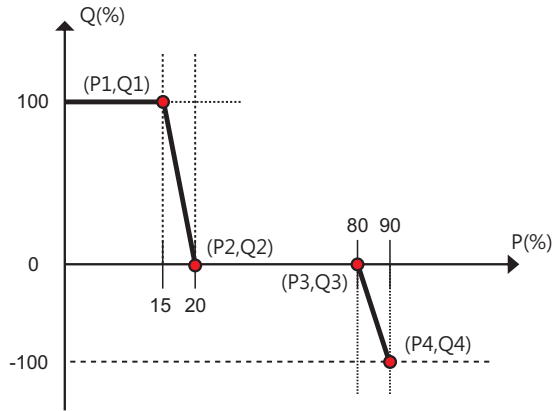

V Lock-in / Lock-out Setting:

- When voltage $V > V$ Lock-in, the Q(P) mode is activated.
- When voltage $V < V$ Lock-out, the Q(P) mode is deactivated.

5.2.2.5.4 Cosφ Setpoint Mode:

Command Code	Command Name	Description	Default (EN50549-1)
0x02E8	CTRL_MODE	Control mode	Q_Ctrl_mode = cosφsetpoint
0x02EB	Q_TAU	The time constant for reactive power setting	$\tau=3\text{sec}$
0x02EE	PF_SET	cosφ set point	PF = 1

In Cosφ Setpoint Mode, the reactive power is determined by PF_SET (0x02EE). The ramp-rate follows Q_TAU (0x02EB). For example, with TAU = 3 s, the output reaches approximately 90% of the target reactive power in about 9 s (3 × time constant).

The magnitude of reactive power is determined by both PF_SET and P_SET (0x02EC).

The conversion formula for PF_SET is:

$Q > 0$ (lagging): $PF_SET = PF \times 100$

$Q < 0$ (leading): $PF_SET = - PF \times 100$

Example:

If P_SET = 4500 W and PF = leading 0.9 (PF_SET = -90), then:

Apparent power = 5000 VA (4500 / 0.9)

Reactive power = -2180 VAR (-5000 × $\sqrt{1 - 0.9^2}$)

NOTE : If P_SET exceeds the maximum apparent power rating (5000VA), the output will be automatically derated.

For example, if P_SET = 5000 W and PF_SET = -90, the actual active power will only be 4500 W.

5.2.2.5.5 Cosφ(P) Setpoint Mode:

Command Code	Command Name	Description	Default (EN50549-1)
0x02E8	CTRL_MODE	Control mode	Q_Ctrl_mode = cosφ(P)
0x02EB	Q_TAU	The time constant for reactive power setting	$\tau=3\text{sec}$
0x02EF	PF_P_LOCKIN_V	Lock in voltage for cosφ(P) mode	disable
0x02F0	PF_P_LOCKOUT_V	Lock out voltage for cosφ(P) mode	disable
0x02F1	PF_P_CURVE_PF1	PF1 on the cosφ(P) Curve	PF=1
0x02F2	PF_P_CURVE_P1	P1 on the cosφ(P) Curve	20%Pn
0x02F3	PF_P_CURVE_PF2	PF2 on the cosφ(P) Curve	PF=1
0x02F4	PF_P_CURVE_P2	P2 on the cosφ(P) Curve	40%Pn
0x02F5	PF_P_CURVE_PF3	PF3 on the cosφ(P) Curve	PF=1
0x02F6	PF_P_CURVE_P3	P3 on the cosφ(P) Curve	50%Pn
0x02F7	PF_P_CURVE_PF4	PF4 on the cosφ(P) Curve	PF = 0.9(abs.)
0x02F8	PF_P_CURVE_P4	P4 on the cosφ(P) Curve	100%Pn

Cosφ(P) settings: voltage values must satisfy $P4 > P3 > P2 > P1$.

The $\cos\phi(P)$ curve defines how reactive power varies with active power, using registers P1, PF1 ~ P4, PF4 (0x02F1~0x02F8). The device determines the Qcmd based on the grid-connected active power. The ramp-rate follows Q_TAU(0x02EB). For example, when Q_TAU = 3 seconds, the device reaches 90% of the target reactive power within approximately 9 seconds (three time constants).

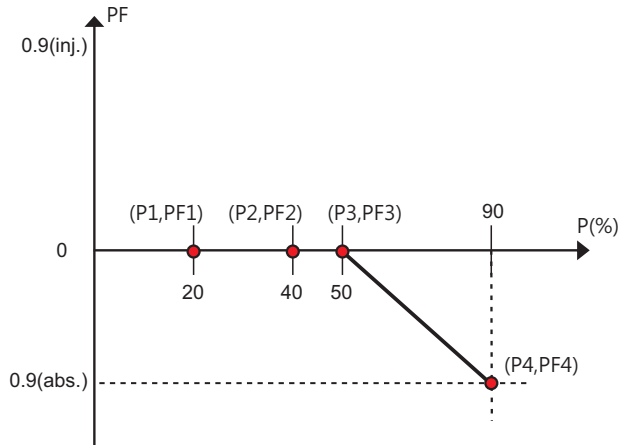

V Lock-in / Lock-out Setting:

- When voltage $V > V$ Lock-in, the $\cos\phi(P)$ mode is activated.
- When voltage $V < V$ Lock-out, the $\cos\phi(P)$ mode is deactivated.

5.2.2.6 Power Derating Control

The device can deliver its full rated power ($S_{max} = 5000$ VA) in normal conditions.

However, if the grid voltage falls below 85% of U_n or the grid frequency rises above the configured threshold, the device proportionally reduces its output. Depending on the settings, it may also absorb power from the AC grid in a constant power way. To avoid battery overcharge, when the measured charge voltage exceeds the value set in CURVE_FV (0x00B2), the device automatically decreases the charging power to as low as 0%.

Derating curve VA by operating U

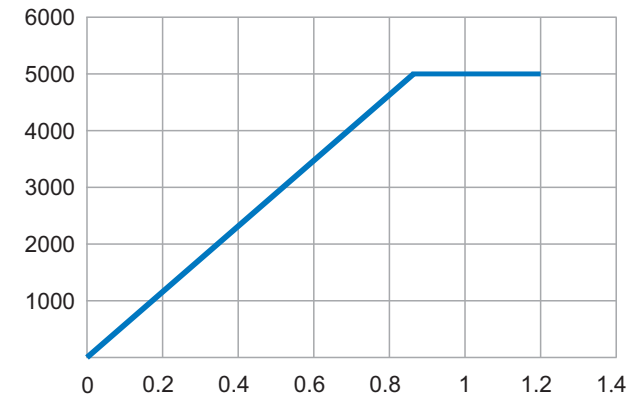

NOTE : In Grid-tied Mode, charging is always performed at constant power, even when used together with Charger Mode. The parameters CURVE_CC, CURVE_CV, CURVE_FV, and CURVE_TC become active only when the device enters Charger Mode because the battery voltage is low.

5.2.2.7 Over-voltage/Under-voltage Ride Through Setting (OVRT & UVRT)

The fault-ride-through (FRT) function operates according to the curve shown below. It ensures that the device can withstand abnormal grid voltage conditions and quickly restore power output when the grid returns to the normal range within a short period.

- (1) Cease-to-Energize Region: When the grid voltage enters the unloading region (below 80% or above 110% of nominal), I_{cmd} is forced to 0 A. Output ramps: 20% of I_{ac} (rated) within 60 ms, and 10% of I_{ac} (rated) within 100 ms.
- (2) Disconnected Region: When the grid voltage enters the disconnection zone, the relay trips and PWM output is stopped.

(3) Continuous Work Region: When the grid voltage recovers to the continuous operation range, power output is quickly restored to over 90% of the pre-fault power within 1 second ($T_{an_90\%} < 1\text{ s}$).

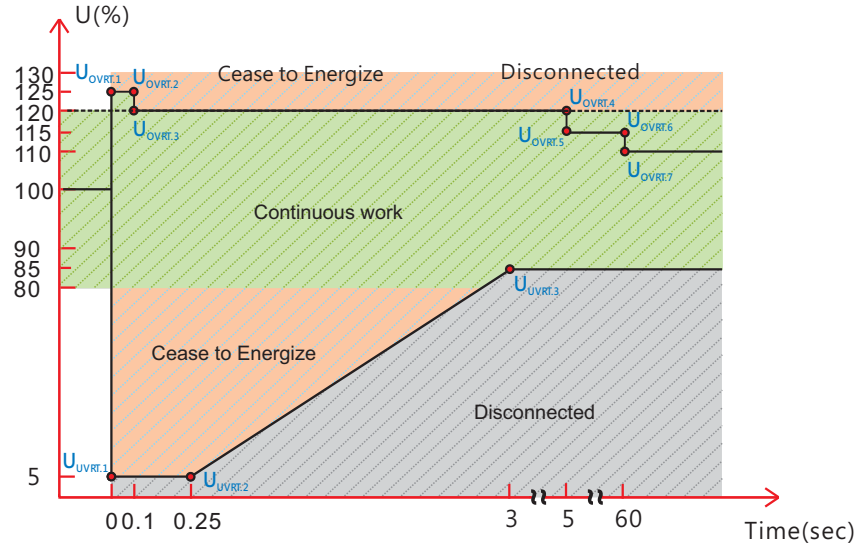

The ride-through commands are as follows :

Command Code	Command Name	Description	Default (EN50549-1)
0x02E4	SAFTY_FUNC_CONFIG	Safety function configuration	UVRT = enable OVRT = enable
0x03D9	UVRT_VOLT1	V1 on the UVRT Curve	5%Un
0x03DA	UVRT_TIME1	T1 on the UVRT Curve	0sec
0x03DB	UVRT_VOLT2	V2 on the UVRT Curve	5%Un
0x03DC	UVRT_TIME2	T2 on the UVRT Curve	0.25sec
0x03DD	UVRT_VOLT3	V3 on the UVRT Curve	85%Un
0x03DE	UVRT_TIME3	T3 on the UVRT Curve	3sec
0x03DF	UVRT_VOLT4	V4 on the UVRT Curve	85%Un
0x03E0	UVRT_TIME4	T4 on the UVRT Curve	3sec

Command Code	Command Name	Description	Default (EN50549-1)
0x03E1	UVRT_VOLT5	V5 on the UVRT Curve	85%Un
0x03E2	UVRT_TIME5	T5 on the UVRT Curve	3sec
0x03E3	UVRT_VOLT6	V6 on the UVRT Curve	85%Un
0x03E4	UVRT_TIME6	T6 on the UVRT Curve	3sec
0x03E5	UVRT_VOLT7	V7 on the UVRT Curve	85%Un
0x03E6	UVRT_TIME7	T7 on the UVRT Curve	3sec
0x0468	OVRT_VOLT1	V1 on the OVRT Curve	125%Un
0x0469	OVRT_TIME1	T1 on the OVRT Curve	0sec
0x046A	OVRT_VOLT2	V2 on the OVRT Curve	125%Un
0x046B	OVRT_TIME2	T2 on the OVRT Curve	0.1sec
0x046C	OVRT_VOLT3	V3 on the OVRT Curve	120%Un
0x046D	OVRT_TIME3	T3 on the OVRT Curve	0.1sec
0x046E	OVRT_VOLT4	V4 on the OVRT Curve	120%Un
0x046F	OVRT_TIME4	T4 on the OVRT Curve	5sec
0x0470	OVRT_VOLT5	V5 on the OVRT Curve	115%Un
0x0471	OVRT_TIME5	T5 on the OVRT Curve	5sec
0x0472	OVRT_VOLT6	V6 on the OVRT Curve	115%Un
0x0473	OVRT_TIME6	T6 on the OVRT Curve	60sec
0x0474	OVRT_VOLT7	V7 on the OVRT Curve	110%Un
0x0475	OVRT_TIME7	T7 on the OVRT Curve	60sec

※ OVRT/UVRT settings: $T3 < T4 < T5 < T6 < T7$. If only 5 points are used, set (V6, T6) and (V7, T7) to be the same as the last valid point.

5.2.2.8 LFSM Setting

The LFSM (Limited Frequency Sensitive Mode) control is divided into LFSM-O (power response to overfrequency) and LFSM-U (power response to underfrequency).

5.2.2.8.1 LFSM-O:

Command Code	Command Name	Description	Default (EN50549-1)
0x02E4	SAFTY_FUNC_CONFIG	Safty function configuration	LFSMO = enable
0x0609	LFSMO_FREQ_START	Start frqncy of LFSM-O	50.2Hz
0x060A	LFSMO_FREQ_STOP	Stop frqncy of LFSM-O	0 (disable)
0x060B	LFSMO_STOP_DLY	Stop deay of LFSM-O	0sec
0x060C	LFSMO_DROOP_RATE	Droop rate of LFSM-O	5%
0x060D	LFSMO_ACTIVE_DLY	Activation delay of LFSM-O	0sec

There are two operation modes for LFSM-O, Power Follows Frequency and Power Return NOT Follows Frequency. The mode selection depends on the relationship between LFSMO_FREQ_START (0x0609) and LFSMO_FREQ_STOP (0x060A).

Power Follows Frequency:

$LFSMO_FREQ_STOP \geq LFSMO_FREQ_START$.

Power Return NOT Follows Frequency:

$LFSMO_FREQ_STOP < LFSMO_FREQ_START$.

If frequency rises to 52 Hz, LFSM-O is disabled.

Power Follows Frequency:

When the frequency exceeds F_{start} (LFSMO_FREQ_START (0x0609)), the device reduces power from the current command $P_{cmd}(1)$, so the total output is: $P_{cmd} = P_{cmd}(1) - \Delta P$ (power reduction)

$\Delta P/f$ slope is determined by the LFSMO_DROOP_RATE (0x060C) command or the s value.

The relationship between ΔP and s :

$$\Delta P = \frac{1_{SET}}{s} \cdot \frac{f_{start} - f_{ac}}{f_n} \cdot P_{ref} \cdot 2\% \leq s \leq 12\%$$

For energy storage systems (ESS), P_{ref} uses the maximum output power P_n as the reference.

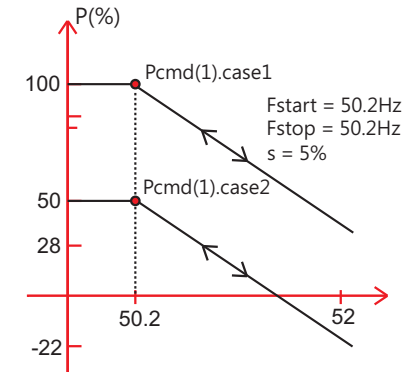

Power Return NOT Follows Frequency:

When this mode is chosen, ΔP holds its previously reduced power level even the frequency is decreased. ΔP only returns to its maximum power setting (or P_{SET} (0x02EC)) when the frequency is equal to or lower than the value of LFSMO_FREQ_STOP.

Additionally, LFSMO_STOP_DLY (0x060B) can be used to set a delay time before ΔP is restored once the frequency criterion is met.

The below curve give a visualization of how the mode behaves.

LFSM-O is activated when AC frequency exceeds

LFSMO_FREQ_START (50.2Hz). From $P_{cmd}(1)$ to 51 Hz (1), the power reduction follows the droop rate defined by LFSMO_DROOP_RATE (0x060C). When the frequency decreases to 50.3 Hz (2), the output power stays at the level corresponding to 51 Hz rather than increasing along the curve. If the frequency rises above 51 Hz up to 51.8 Hz (3), the output power is further reduced to a new level. It is only when the frequency returns to LFSMO_FREQ_STOP (50.1 Hz) and remains there for the duration specified by LFSMO_STOP_DLY, LFSM-O is deactivated and ΔP returns to 100%.

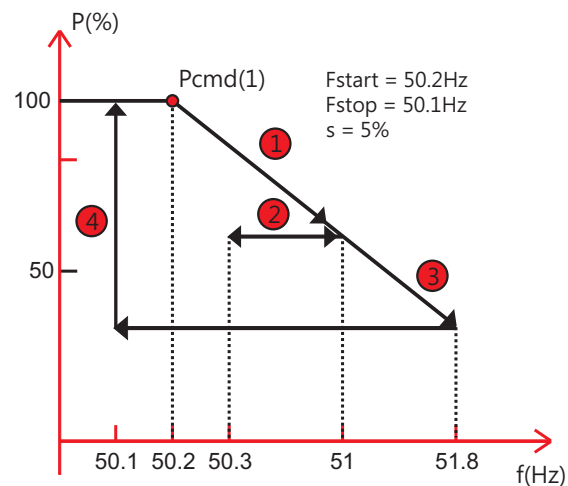

When exiting LFSM-O and returning to normal operation, the output power will be restored from $P_{cmd}(1) + \Delta P$ back to $P_{SET}(0x02EC)$. During this process, the power ramp-up (soft change) follows the $RECONNECT_P_RATE(0x02D8)$ command.

5.2.2.8.2 LFSM-U:

The mechanism is similar to LFSM-O. When the grid frequency drops to F_{start} , this function is activated, increasing the current output power $P_{cmd}(1)$ by adding a frequency compensation ΔP to support the grid.

$$P_{cmd} = P_{cmd}(1) - \Delta P$$

The ride-through commands are as follows :

Command Code	Command Name	Description	Default (EN50549-1)
0x02E4	SAFTY_FUNC_CONFIG	Safty function configuration	LFSMU = enable
0x060E	LFSMU_FREQ_START	Start frqncy of LFSM-U	49.8Hz
0x060F	LFSMU_FREQ_STOP	Stop frqncy of LFSM-U	0 (disable)
0x0610	LFSMU_STOP_DLY	Stop deay of LFSM-U	30sec
0x0611	LFSMU_DROOP_RATE	Droop rate of LFSM-U	2%
0x0612	LFSMU_ACTIVE_DLY	Activation delay of LFSM-U	0sec

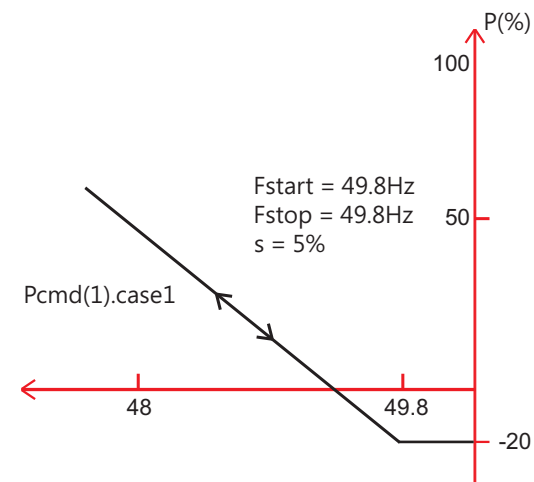

5.2.2.9 LFSM Pref Setting

The $LFSM_P_REF(0x0613)$ command is used to set Pref .

The ride-through commands are as follows :

Command Code	Command Name	Description	Default (EN50549-1)
0x0613	LFSM_P_REF	LFSM Pref setting	PREF = Pn

In most energy storage system (ESS) applications, Pref is set to 0, meaning Pref = Pn (rated power). If $LFSM_P_REF$ is set to 1, then Pref is calculated dynamically according to: Pref = PM, where PM = Pmax (maximum target output power) - Pnow (current operating power).

Example 1 - LFSM-U :

If the device is charging at 2500 W before activation, and the maximum discharging power is 5000 W, then PM = 5000 - (-2500) = 7500 W.

Example 2 - LFSM-O :

If the device is charging at 2500 W before activation, and the maximum charging power is 5000 W, then PM = 5000 - 2500 = 2500 W.

5.2.2.10 ROCOF(Rate-of-change-of-frequency) Protection

ROCOF is a passive anti-islanding detection function. The device monitors the average frequency change rate within the time window defined by the $ROCOF_WINDOW_TIME(0x065A)$ command. If the detected rate of change exceeds the threshold set by $ROCOF_SLOPE(0x0659)$, the device will trigger NS-Protection, disconnecting the AC relay and disabling output.

The ride-through commands are as follows :

Command Code	Command Name	Description	Default (EN50549-1)
0x02E4	SAFTY_FUNC_CONFIG	Safty function configuration	ROCOF = disable
0x0659	ROCOF_SLOPE	Slope setting of ROCOF	2.5Hz/sec
0x065A	ROCOF_WINDOW_TIME	Window time of ROCOF	500ms

5.2.2.11 Network and System protection (NS Protection)

The device includes a grid disconnection protection function. It continuously monitors the grid voltage and frequency at the AC connection point through internal sensors, with measurement accuracies of $\pm 1\%U_n$ for voltage and ± 0.05 Hz for frequency.

Protection is categorized into four conditions: OV (Overvoltage), UV (Undervoltage), OF (Overfrequency), and UF (Underfrequency). Each condition includes multiple protection levels and corresponding trip times. First-level protection typically represents slow protection with multi-cycle response. Second-level and higher protections provide fast protection with response times ≤ 2 cycles.

The ride-through commands are as follows :

Command Code	Command Name	Description	Default (EN50549-1)
0x0640	UVP1_VOLT	1st-level undervoltage protection (V)	80%Un
0x0641	UVP1_TIME	1st-level undervoltage trip time (T)	3 sec
0x0642	UVP2_VOLT	2nd-level undervoltage protection (V)	45%Un
0x0643	UVP2_TIME	2nd-level undervoltage trip time (T)	0.3sec
0x0644	UVP3_VOLT	3rd-level undervoltage protection (V)	45%Un
0x0645	UVP3_TIME	3rd-level undervoltage trip time (T)	0.3sec

Command Code	Command Name	Description	Default (EN50549-1)
0x0646	OVP1_VOLT	1st-level overvoltage protection (V)	125%Un
0x0647	OVP1_TIME	1st-level overvoltage trip time (T)	0.1 sec
0x0648	OVP2_VOLT	2nd-level overvoltage protection (V)	125%Un
0x0649	OVP2_TIME	2nd-level overvoltage trip time (T)	0.1 sec
0x064A	OVP3_VOLT	3rd-level overvoltage protection (V)	125%Un
0x064B	OVP3_TIME	3rd-level overvoltage trip time (T)	0.1 sec
0x064C	UFP1_FREQ	1st-level underfrequency threshold (H)	47.5Hz
0x064D	UFP1_TIME	1st-level underfrequency trip time (T)	0.1 sec
0x064E	UFP2_FREQ	2nd-level underfrequency threshold (H)	47.5Hz
0x064F	UFP2_TIME	2nd-level underfrequency trip time (T)	0.1 sec
0x0650	UFP3_FREQ	3rd-level underfrequency threshold (H)	47.5Hz
0x0651	UFP3_TIME	3rd-level underfrequency trip time (T)	0.1 sec
0x0652	OFF1_FREQ	1st-level overfrequency threshold (Hz)	51.5Hz
0x0653	OFF1_TIME	1st-level overfrequency trip time (T)	0.1 sec
0x0654	OFF2_FREQ	2nd-level overfrequency threshold (Hz)	51.5Hz
0x0655	OFF2_TIME	2nd-level overfrequency trip time (T)	0.1 sec
0x0656	OFF3_FREQ	3rd-level overfrequency threshold (Hz)	51.5Hz
0x0657	OFF3_TIME	3rd-level overfrequency trip time (T)	0.1 sec
0x0658	OVP10MIN_VOLT	10-minute average overvoltage protection point	110%Un

OVP10min (0x0658) is based on the moving 10-minute RMS average of the input voltage, updated every 3 seconds.

5.2.2.12 EEPROM Storage

The commands of 0x0200–0x0900 are frequently modified by the DSO. To avoid excessive EEPROM write cycles, modified parameters are not stored into the EEPROM. As a result, these commands are reloaded with their default values when the device is powered off and restarted.

Related commands are as follows:

Command Code	Command Name	Description	Range	Default (EN50549-1)
0x02D1	GRID_TIME_REMOTE	Grid connection ON/OFF control	00h(OFF)/01h(ON)	01h
0x02EC	P_SET	Maximum active power output setting	0~100%	100%
0x02ED	Q_SET	Maximum reactive power output setting	-100~100%	0%
0x02EE	PF_SET	cosφ set point	0.9~1 over 0.9~1 under	PF=1

Commands outside the range of 0x0200–0x0900 are stored in the EEPROM (the EEP_CONFIG function in SYSTEM_CONFIG (CAN:0x00C2 ; MOD:0x00C4) is not supported).

To enable EEPROM storage for the four commands listed above, set CTRL_STORAGE_CFG[8] = 1 in the CTRL_MODE (0x02E8) command.

5.2.2.13 Password for the Grid Connection Parameters

According to the safety standard, only authorized DSO personnel are allowed to modify grid connection parameters. Access control is applied to prevent unauthorized changes. See Sections 6.1.4.4 and 6.2.6.3 for detailed configuration instructions.

5.2.3 Special condition behavior: Grid-tied Mode + Charger Mode

In contrast to Grid-tied Mode only (without combining with Charger Mode) in which the BIC-5K in Grid-tied Mode will not charge the battery automatically, even when the battery voltage is low. When the BIC-5K operates in Grid-tied Mode + Charger Mode, it will automatically switch to Charger Mode and charging the battery whenever a low battery voltage is detected (battery voltage < BAT_ALM_VOLT(0x00B9)).

The CHG_FIRST (Low byte: bit 4 in INV_OPERATION(0x0100)) setting defines how the device behaves on startup:

- CHG_FIRST = 1 : The BIC-5K charges the battery to full capacity first, then switches to Grid-tied Mode for grid connection.
- CHG_FIRST = 0 : The BIC-5K starts directly in Grid-tied Mode and only switches to Charger Mode automatically if the battery voltage drops too low.

Only one mode - either Grid-tied Mode or Charger Mode - can be active at any time. As a result, while the device is in Grid-tied Mode, power absorption is performed at constant power, rather than following the charge curves defined by Charger Mode.

In Charger Mode, the device will not return to Grid-tied Mode until the battery is fully charged (For three-stage charging, this occurs when CURVE_FV_TIMEOUT (0x00B7) is triggered), regardless of any grid commands received. The only way to force the device back to Grid-tied Mode before charging is complete is to disable Charger Mode through the INV_OPERATION (0x0100) command.

For more details on Charger Mode, please refer to Section 5.3: Charger Mode.

5.3 Charger Mode

Charger Mode supports both two-stage and three-stage charging. Two-stage charging provides a simple and fast charging process. Three-stage charging is similar to two-stage charging but maintains the battery voltage after the battery is fully charged. Users can select either two-stage or three-stage charging according to their requirements.

Mode Selection: Set low byte bit2 (CHG_END) at "logic high" in the INV_OPERATION(0x0100) command.

The supported commands are as follows:

Command Code	Command Name	Description	Default
0x00B4	CURVE_CONFIG	Configuration setting of charging curve	0x0400
0x00B8	CHG_STATUS	Charger's status reporting	---
0x00B0	CURVE_CC	Constant current setting of charge curve	24V:171A 48V: 85.5A 96V: 44.5A 380V: 12.5A
0x00B1	CURVE_CV	Constant voltage setting of charge curve	24V:28.8V 48V: 57.6V 96V: 112V 380V: 400V
0x00B2	CURVE_FV	Floating voltage setting of charge curve	24V:27.6V 48V: 55.2V 96V: 108.8V 380V: 385V
0x00B3	CURVE_TC	Taper current setting of charge curve	24V:17.1A 48V: 8.55A 96V: 4.45A 380V: 1.25A
0x00B5	CURVE_CC_TIMEOUT	CC stage timeout setting value of charging curve	600 minute
0x00B6	CURVE_CV_TIMEOUT	CV stage timeout setting value of charging curve	600 minute
0x00B7	CURVE_FV_TIMEOUT	FV stage timeout setting value of charging curve	600 minute

5.3.1.2 Stage Charging

In the initial stage of charging, the charger charges the battery with the maximum current. After a period of time (depending on the battery capacity), the charging current decreases gradually. When the charging current drops to 10% of the rated current and then LED indicator lights up in green, indicating that the charging process is complete.

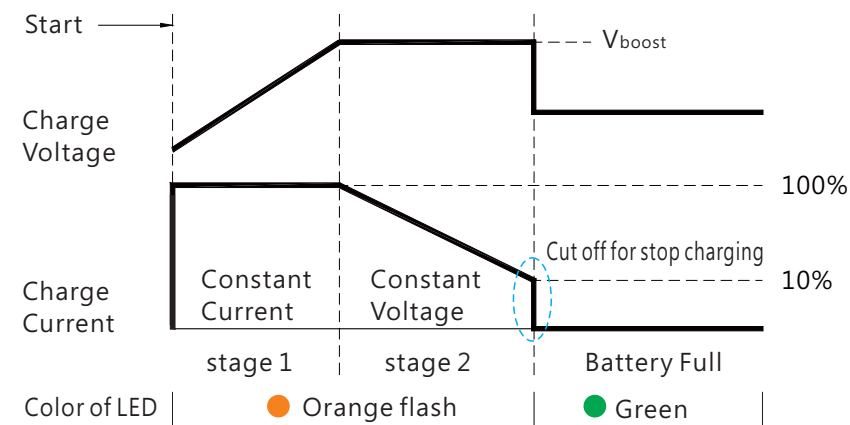

Explanation of 2 stage charging curve

- ① Initial stage (battery analysis):
Charger will detect and determine whether the battery is properly connected or it is already fully charged. If no battery is connected or if the battery voltage is out of range, the device will shut down.
 - ② Stage 1 (Constant current):
Maximum constant current (CURVE_CC) is applied for fast charging, until the voltage of battery reaches to boost voltage (CURVE_CV).
 - ③ Stage 2 (Constant voltage):
In this stage, charger applies a constant voltage (CURVE_CV) on the battery. Charging current decreases gradually and then shuts down when charging current drops to 10% of rated current (CURVE_TC).
- * Suitable for lead-acid batteries, such as flooded water type, Gelcolloid type, AGM adsorption glass fiber, and lithium batteries, such as lithium-iron, lithium-manganese, ternary lithium.

24V model			
Description	CC(default)	TC(default)	V _{boost}
Default, programmable	171A	17.1A	28.8V
Pre-defined, gel battery			28.0V
Pre-defined, flooded battery			28.4V
Pre-defined, LiFeO4 battery			29.2V

48V model			
Description	CC(default)	TC(default)	V _{boost}
Default, programmable	85.5A	8.55A	57.6V
Pre-defined, gel battery			56.0V
Pre-defined, flooded battery			56.8V
Pre-defined, LiFeO4 battery			58.4V

96V model			
Description	CC(default)	TC(default)	V _{boost}
Default, programmable	44.5A	4.45A	112V

380V model			
Description	CC(default)	TC(default)	V _{boost}
Default, programmable	12.5A	1.25A	400V
Pre-defined, gel battery			390V
Pre-defined, flooded battery			395V
Pre-defined, LiFeO4 battery			400V

5.3.2.3 Stage Charging

In the initial stage of charging, the charger charges the battery with the maximum current. After a period of time (depending on the battery capacity), the charging current decreases gradually. When the charging current drops to 10% of the rated current, LED indicator lights up in green, indicating that the charging process is completed and the charger remains at float charging stage.

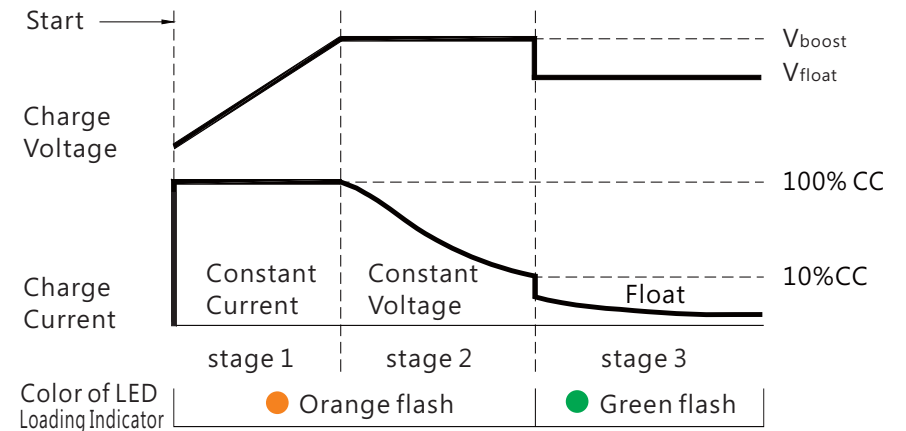

Explanation of 3 stage charging curve

- ① 1 Initial stage (battery analysis):
Charger will detect and determine whether the battery is properly connected or it is already fully charged. If no battery is connected or if the battery voltage is out of range, the device will shut down.
 - ② 2 Stage 1 (Constant current):
Maximum constant current (CURVE_CC) is applied for fast charging, until the voltage of battery reaches to boost voltage (CURVE_CV).
 - ③ 3 Stage 2 (Constant voltage):
In this stage, charger applies a constant voltage (CURVE_CV) on the battery. Charging current decreases gradually and then goes into the final stage when charging current drops to 10% of rated current (CURVE_TC).
 - ④ 4 Stage 3 (float charging):
The charger is able to provide a float voltage (CURVE_FV) after 2 stage charging in order to keep the battery fully charged at all times. Especially suitable for lead-acid batteries.
- * Suitable for lead-acid batteries, such as flooded water type, Gelcolloid type, AGM adsorption glass fiber, and lithium batteries, such as lithium-iron, lithium-manganese, ternary lithium.

24V model				
Description	CC(default)	TC(default)	V _{boost}	V _{float} (3 stage only)
Default, programmable	171A	17.1A	28.8V	27.6V
Pre-defined, gel battery			28.0V	27.2V
Pre-defined, flooded battery			28.4V	26.8V
Pre-defined, LiFeO4 battery			29.2V	28.0V

48V model				
Description	CC(default)	TC(default)	V _{boost}	V _{float} (3 stage only)
Default, programmable	85.5A	8.55A	57.6V	55.2V
Pre-defined, gel battery			56.0V	54.4V
Pre-defined, flooded battery			56.8V	53.6V
Pre-defined, LiFeO4 battery			58.4V	56.0V

96V model				
Description	CC(default)	TC(default)	V _{boost}	V _{float} (3 stage only)
Default, programmable	44.5A	4.45A	112V	108.8V

380V model				
Description	CC(default)	TC(default)	V _{boost}	V _{float} (3 stage only)
Default, programmable	12.5A	1.25A	400V	385V
Pre-defined, gel battery			390V	380V
Pre-defined, flooded battery			395V	372V
Pre-defined, LiFeO4 battery			400V	388V

5.4 Inrush Current Limiting

- Built-in AC inrush current limiting circuit
- The inrush current limiting circuit limits excessive startup current. To prevent elevated inrush current resulting from rapid restarts, a minimum cool down period of 10 seconds is required before turning the device on again.

5.5 Power Factor Correction (PFC)

- Built-in active power factor correction (PFC) function for AC to DC conversion, power factor (PF) will be 0.98 or better at full load condition in AC to DC conversion. PF will be less than 0.98 if it is not at full load condition during AC to DC conversion.

5.6 Fan Speed control

- Built-in fan speed control circuit, fan speed changes automatically depending on internal temperature.

5.7 Fault Signal

- Fault signal is used to inform application equipment that whether the device is operating normally. When it is OLP, SCP or OTP, BIC-5K will send a high level of fault signal 100ms in advance to notify the application before shutting down the supply. A fault signal will send out at the same time of shutting down operation in the reset of protection (e.g. AC_fail).
- Maximum output current 4mA.

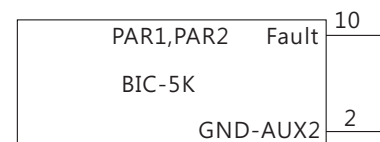

Fault to GND-AUX2	Condition
-0.5~0.5V	Normal working
4.5~5.5V	In an abnormal condition

5.8 DC-OK Signal

- Built-in DC output voltage detection circuit.
- Maximum output current 4mA.

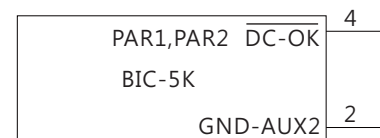

DC-OK to GND-AUX2	Condition
-0.5~2.5V	DC OK
4.5~5.5V	Abnormal in DC end

NOTE: Refert to section 4.6 for criteria.

5.9 Remote Control

- Built-in Remote ON/OFF control circuit, which is used to turn on/off the device.
- Please be aware that "Remote ON/OFF " +5V-AUX" on PAR1,PAR2 should be linked together to allow the unit to operate normally; if kept open, there will be no output.
- Maximum input voltage 5.5V.
- The devices in BIC/Grid-tied/Charger Mode trun on when Remote Control is on.

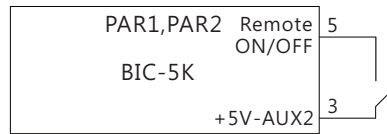

REMOTE ON_OFF to +5V-AUX2	Action
Short	ON
Open	OFF

5.10 Current Sharing

BIC-5K has the built-in active current sharing function and can be connected in parallel, up to 6 units, to provide higher output power as exhibited below :

- The power supplies should be paralleled using short and large diameter wiring and then connected to the load.
- In parallel connection, power supply with the highest output Voltage will be the master unit and its Vout
- The total output current must not exceed the value determined by the following equation:
Maximum output current at parallel operation=(Rated current per unit)× (Number of unit)×0.95
- When the total output current is less than 5% of the total rated current, or say (5% of Rated current per unit)×(Number of unit) the current shared among units may not be balanced.
- PAR1/PAR2, PRL Function pin connection

Parallel	PSU1		PSU2		PSU3		PSU4		PSU5		PSU6	
	PAR1/PAR2	PRL	PAR1/PAR2	PRL	PAR1/PAR2	PRL	PAR1/PAR2	PRL	PAR1/PAR2	PRL	PAR1/PAR2	PRL
1 unit	X	ON	—	—	—	—	—	—	—	—	—	—
2 unit	V	ON	V	ON	—	—	—	—	—	—	—	—
3 unit	V	ON	V	OFF	V	ON	—	—	—	—	—	—
4 unit	V	ON	V	OFF	V	OFF	V	ON	—	—	—	—
5 unit	V	ON	V	OFF	V	OFF	V	OFF	V	ON	—	—
6 unit	V	ON	V	OFF	V	OFF	V	OFF	V	OFF	V	ON

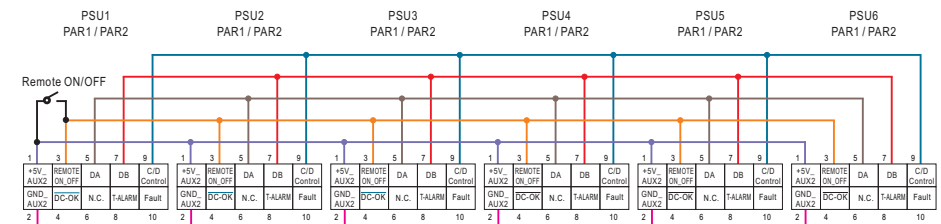
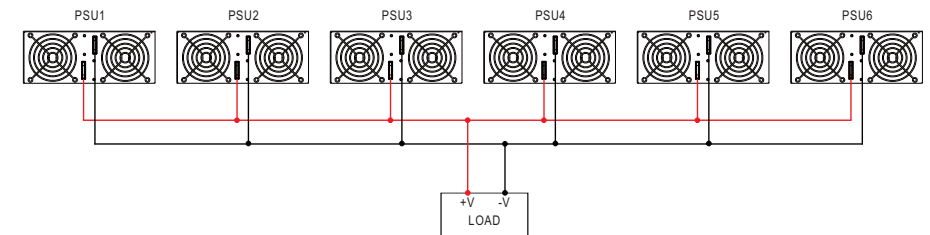

↑
If the lines of PAR1 / PAR2 are too long, they should be twisted in pairs to avoid the noise.

NOTE: Current Sharing function is only available for BIC Mode.

5.10.1 Parallel Operation with 3-phase 4-wire System

When operating BIC-5K units in parallel, their AC side can be connected to either a single-phase or three-phase, four-wire AC system.

To ensure balanced current distribution in the AC system, it is generally recommended to evenly distribute the BIC-5K units across the phases. For example, when using six BIC-5K units in parallel, two units can be connected with AC/L to L1 and AC/N to N, another two units with AC/L to L2 and AC/N to N, and the remaining two with AC/L to L3 and AC/N to N, as illustrated in the diagram below.

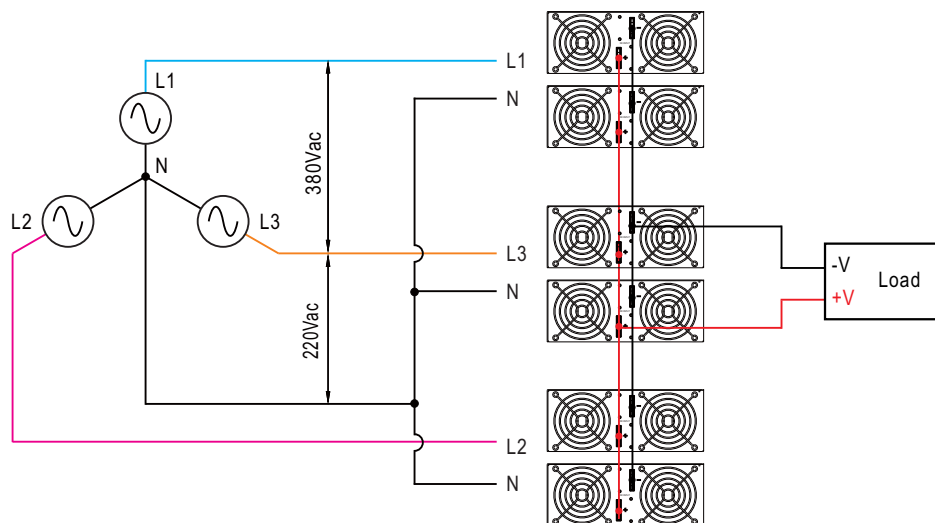

5.11 Factory Resetting

Users can follow the steps below to restore factory settings for commands: 0x0000, 0x0020, 0x0030, 0x00B0, 0x00B1, 0x00B2, 0x00B3, 0x00B4, 0x00B5, 0x00B6, 0x00B7, 0x00B9, 0x00BA, 0x00BB, 0x00C2, 0x0100, 0x0140, 0x0143, 0x0150, 0x02D2, 0x02D3, 0x02D4, 0x02D5, 0x02D6, 0x02D7, 0x02D7, 0x02D8, 0x02E4, 0x02E8, 0x02E9, 0x02EA, 0x02EB, 0x02EF ~ 0x065A) :

- ① Set the rotary switches of AD1 and AD2 to position 0.
- ② Turn on the device with remote off by applying DC energy to the DC terminals or connecting the AC utility to the AC terminals. There should be no AC output in this condition.
- ③ Rotate the AD2 from position 0 to position Z and then back to position 0 again within 15 seconds after device turned on.
- ④ If the LED indicators flash green three times, it means that the reset procedure has been done successfully. Reboot to apply the default settings.
- ⑤ If the EEPROM storage function was DISABLE (high byte bit 2 set to "logic 1" in SYSTEM_CONFIG), please perform step ① - ④ again to fully restore the parameters back to factory settings

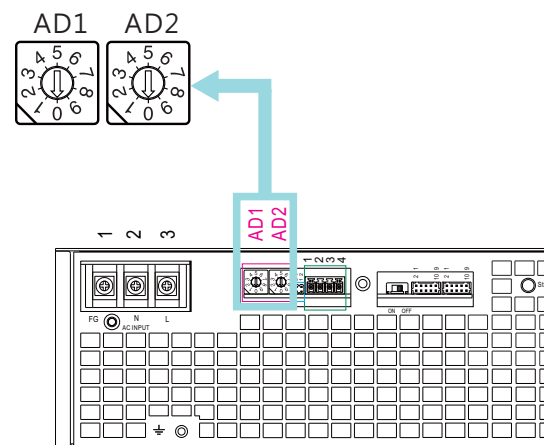

NOTE :
This procedure resets all settings in Grid-tied Mode to factory defaults, including password for the grid connection parameters. When used in Grid-tied Mode, consult the local DSO or power company first to prevent grid tripped or other grid connection issues.

6.Communication Protocol

6.1 CANBus Protocol

CANBus communication interface provides control and monitoring functions. It is helpful when users intent to modify the parameters remotely. Users can read and write the parameters through the bus, which includes BIC / Grid-tied / Charger Mode seting, operation ON/OFF, charge voltage / current, discharge voltage/ current, temperature monitoring, etc.

6.1.1 CANBus Specification

- Physical layer specification

This protocol follows CAN ISO-11898 with Baud rate of 250Kbps

- Data Frame

This protocol utilizes Extended CAN 29-bit identifier frame format or CAN 2.0B.

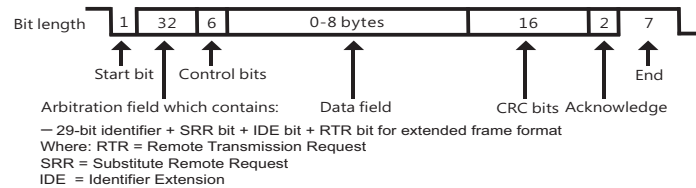

- Communication Timing

Min. request period (Controller to BIC-5K): 50mSec ◦
 Max. response time (BIC-5K to Controller): 12.5mSec ◦
 Min. packet margin time (Controller to BIC-5K): 12.5mSec ◦

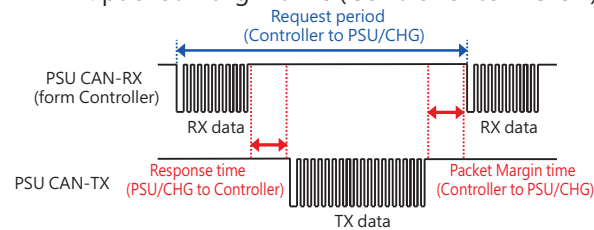

- Data Field Format

Controller to BIC

Write: Please refer to section 6.1.4.1

Data filed bytes

0	1	2	3
COMD. low byte	COMD. high byte	Data low byte	Data high byte

Read: Please refer to section 6.1.4.2

Data filed bytes

0	1
COMD. low byte	COMD. high byte

BIC to controller

Response: Please refer to section 6.4.1.2

Data filed bytes

0	1	2	7
COMD. low byte	COMD. high byte	Data low 1	Data high 6

Note : BIC will not send data back when write parameters, such as VOUT_SET.

6.1.2 Message ID Definition

Each BIC-5K unit should have their unique and own device address to communicate over the bus. AD1 and AD2 allow users to designate an address for their units (with maximum of 64 addresses).

Description	Message ID
BIC-5K to controller Message ID	0x00C02XX
Controller to BIC-5K Message ID	0x00C03XX
Controller broadcasts toBIC-5K Message ID	0x00C03FF

Note : XX means the address of the BIC-5K. Please refer to 4.7 Communication Address/ID Assignment for detailed.

6.1.3 CANBus command list

ORANGE : BIC Mode Dedicated Commands
BLUE : Grid-tied Mode Dedicated Commands
GREEN : Charger Mode Dedicated Commands

Command Code	Command Name	Transaction Type	# of data Bytes	Description
0x0000	OPERATION	R/W	1	01:ON/00:OFF
0x0020	VOUT_SET*	R/W	2	Charge voltage setting (Factor =0.01)
0x0030	IOUT_SET*	R/W	2	Charge current setting (Factor =0.01)
0x0040	FAULT_STATUS	R	2	Summary status reporting
0x0050	READ_VIN	R	2	Single-phase input voltage (Bypass) (Factor =0.1)
0x0053	READ_IIN	R	2	Single-phase input current(Bypass) (Factor =0.1)
0x0056	READ_FREQ	R	2	Single-phase input frequency(Bypass) (Factor =0.01)
0x0060	READ_VOUT	R	2	DC voltage reading value (Factor =0.01)

Command Code	Command Name	Transaction Type	# of data Bytes	Description
0x0061	READ_IOUT	R	2	DC current reading value (Factor =0.01)
0x0062	READ_TEMPERATURE_1	R	2	Internal ambient temperature (Factor =0.1)
0x0070	READ_FAN_SPEED_1	R	2	Fan speed 1 reading value (Factor =1)
0x0071	READ_FAN_SPEED_2	R	2	Fan speed 2 reading value (Factor =1)
0x0080	MFR_ID_B0B5	R	6	Manufacturer's name
0x0081	MFR_ID_B6B11	R	6	Manufacturer's name
0x0082	MFR_MODEL_B0B5	R	6	Manufacturer's model name
0x0083	MFR_MODEL_B6B11	R	6	Manufacturer's model name
0x0084	MFR_REVISION_B0B5	R	6	Firmware revision
0x0085	MFR_LOCATION_B0B2	R	3	Manufacturer's factory location
0x0086	MFR_DATE_B0B5	R	6	Manufacturer's date
0x0087	MFR_SERIAL_B0B5	R	6	Product serial number
0x0088	MFR_SERIAL_B6B11	R	6	Product serial number
0x00B0	CURVE_CC*	R/W	2	Constant current setting of charge curve (Factor =0.01)
0x00B1	CURVE_CV*	R/W	2	Constant voltage setting of charge curve (Factor =0.01)
0x00B2	CURVE_FV*	R/W	2	Floating voltage setting of charge curve (Factor =0.01)
0x00B3	CURVE_TC*	R/W	2	Taper current setting of charge curve (Factor =0.01)
0x00B4	CURVE_CONFIG	R/W	2	Configuration setting of charging curve
0x00B5	CURVE_CC_TIMEOUT	R/W	2	CC stage timeout setting value of charging curve (Factor =1)
0x00B6	CURVE_CV_TIMEOUT	R/W	2	CV stage timeout setting value of charging curve (Factor =1)

Command Code	Command Name	Transaction Type	# of data Bytes	Description
0x00B7	CURVE_FV_TIMEOUT	R/W	2	FV stage timeout setting value of charging curve (Factor =1)
0x00B8	CHG_STATUS	R	2	Charger's status reporting
0x00B9	BAT_ALM_VOLT*	R/W	2	Battery low voltage alarm threshold (Factor =0.01)
0x00BA	BAT_SHDN_VOLT*	R/W	2	Battery low voltage shutdown threshold (Factor =0.01)
0x00BB	BAT_RCHG_VOLT*	R/W	2	Battery recharge voltage threshold (Factor =0.01)
0x00BC	BAT_OV_ALM_VOLT	R/W	2	Battery high voltage alarm threshold (Factor=0.01)
0x00C0	SCALING_FACTOR	R	6	Scaling ratio
0x00C1	SYSTEM_STATUS	R	2	System status
0x00C2	SYSTEM_CONFIG	R/W	2	System configuration
0x00CF	SETTING_UNLOCK	W	2	Setting unlock for user (NOTE1)
0x0100	INV_OPERATION	R/W	2	Main mode configuration
0x011A	READ_VBAT	R	2	Battery voltage read value (Factor =0.01)
0x011B	READ_CHG_CURR	R	2	Battery current read value (Factor =0.01)
0x011C	BAT_CAPACITY	R	2	Battery capacity percent read value, 0~100%
0x011D	INV_STATUS	R	2	Inverter operation status reading
0x011F	READ_BP_WATT_HI	R	2	Bypass wattage read value (High) (Factor =0.1)
0x0120	READ_BP_WATT_LO	R	2	Bypass wattage read value (Low) (Factor =0.1)

Command Code	Command Name	Transaction Type	# of data Bytes	Description
0x0125	READ_BP_VA_HI	R	2	Bypass apparent power threshold (Factor = 0.1)
0x0126	READ_BP_VA_LO	R	2	Bypass apparent power read value (Low) (Factor = 0.1)
0x0140	DIR_CTRL	R/W	1	A/D or D/A conversion control 00: A/D 01: D/A
0x0141	VOUT_SET_REV*	R/W	2	Discharge voltage setting (Factor = 0.01)
0x0142	IOUT_SET_REV*	R/W	2	Discharge current setting (Factor = 0.01)
0x0143	BIDIR_CONFIG	R/W	2	Bidirectional mode configuration
0x0150	POUT_USER_CMD	R/W	2	Power output control for user (Factor = 0.1)
0x0202	AC_TYPE	R	2	AC type reading
0x0203	INV_STATE	R	2	Operation state reporting
0x0204	CONNECT_STATE	R	2	Grid connection state reporting
0x0205	GRID_ALARM	R	2	Grid mode alarm reporting
0x020B	W	R	2	Active power read value (Factor = 0.1)
0x020C	VA	R	2	Apprent power read value (Factor = 0.1)
0x020D	VAR	R	2	Reactive power read value (Factor = 0.1)
0x020E	PF	R	2	Power factor read value (Factor = 0.01)
0x020F	A	R	2	Total AC current read value (Factor = 0.01)
0x0210	LLV	R	2	Line to line voltage read value (Factor = 0.01)

Command Code	Command Name	Transaction Type	# of data Bytes	Description
0x0211	LNV	R	2	Line to nature voltage read value (Factor = 0.01)
0x0212	HZ	R	2	AC frequency read value (Factor = 0.01)
0x0248	THROT_SRC	R	4	Activated functions for grid control reporting
0x029D	W_MAX_RTG	R	2	Maximum active power output rating (Factor = 1)
0x029E	W_OVR_EXT_RTG	R	2	Rated active power under overexcitation (Factor = 1)
0x029F	W_OVR_EXT_RTG_PF	R	2	Rated power factor under overexcitation (Factor = 0.01)
0x02A0	W_UND_EXT_RTG	R	2	Rated active power under underexcitation (Factor = 1)
0x02A1	W_UND_EXT_RTG_PF	R	2	Rated power factor under underexcitation (Factor = 0.01)
0x02A2	VA_MAX_RTG	R	2	Maximum apparent power output rating (Factor = 1)
0x02A3	VAR_MAX_INJ_RTG	R	2	Rated reactive power during injection (Factor = 1)
0x02A4	VAR_MAX_ABS_RTG	R	2	Rated reactive power during absorption (Factor = 1)
0x02A7	V_NOR_RTG	R	2	Normal AC voltage rating (Factor = 0.01)
0x02A8	V_MAX_RTG	R	2	Maximum AC voltage rating (Factor = 0.01)
0x02A9	V_MIN_RTG	R	2	Minimum AC voltage rating (Factor = 0.01)
0x02AA	A_MAX_RTG	R	2	Maximum AC current rating (Factor = 0.01)
0x02D1	GRID_TIE_REMOTE	R/W	1	Remote on/off for grid mode
0x02D2	CONNECT_UPPER_VOLT	R/W	2	Upper voltage threshold (format, *0.01%Un)

Command Code	Command Name	Transaction Type	# of data Bytes	Description
0x02D3	CONNECT_LOWER_VOLT	R/W	2	Lower voltage threshold (format, *0.01%Un)
0x02D4	CONNECT_UPPER_FREQ	R/W	2	Upper frequency threshold (format, *0.01Hz)
0x02D5	CONNECT_LOWER_FREQ	R/W	2	Lower frequency threshold (format, *0.01Hz)
0x02D6	CONNECT_DLY_TIME	R/W	2	Observation time (format, *0.01sec)
0x02D7	CONNECT_P_RATE	R/W	2	The ramp-rate for connecton (format, *1%Pn/sec)
0x02D8	RECONNECT_P_RATE	R/W	2	The ramp-rate for reconnecton (format, *1%Pn/sec)
0x02E4	SAFTY_FUNC_CONFIG	R/W	2	Safety function configuration
0x02E5	COUNTRY_SET	R/W	1	Country/region configuration
0x02E8	CTRL_MODE	R/W	2	Control mode
0x02E9	P_SET_RATE	R/W	2	The ramp-rate for active power (format, *1%Pn/sec)
0x02EA	P_TAU	R/W	2	The time constant for P(U) (format, *0.01sec)
0x02EB	Q_TAU	R/W	2	The time constant for reactive power setting (format, *0.01sec)
0x02EC	P_SET	R/W	2	Maximum active power output setting (format, *0.1%Pn)
0x02ED	Q_SET	R/W	2	Maximum reactive power output setting (format, *0.1%Qn)
0x02EE	PF_SET	R/W	2	cosφ set point (format, *0.01 PF)
0x02EF	PF_P_LOCKIN_V	R/W	2	Lock in voltage for cosφ(P) mode (format, *0.01%Un)
0x02F0	PF_P_LOCKOUT_V	R/W	2	Lock out voltage for cosφ(P) mode (format, *0.01%Un)

Command Code	Command Name	Transaction Type	# of data Bytes	Description
0x02F1	PF_P_CURVE_PF1	R/W	2	F1 on the cosφ(P) Curve (format, *0.01 PF)
0x02F2	PF_P_CURVE_P1	R/W	2	P1 on the cosφ(P) Curve (format, *0.1%Pn)
0x02F3	PF_P_CURVE_PF2	R/W	2	Pf2 on the cosφ(P) Curve (format, *0.01 PF)
0x02F4	PF_P_CURVE_P2	R/W	2	P2 on the cosφ(P) Curve (format, *0.1%Pn)
0x02F5	PF_P_CURVE_PF3	R/W	2	Pf3 on the cosφ(P) Curve (format, *0.01 PF)
0x02F6	PF_P_CURVE_P3	R/W	2	P3 on the cosφ(P) Curve (format, *0.1%Pn)
0x02F7	PF_P_CURVE_PF4	R/W	2	Pf4 on the cosφ(P) Curve (format, *0.01 PF)
0x02F8	PF_P_CURVE_P4	R/W	2	P4 on the cosφ(P) Curve (format, *0.1%Pn)
0x0327	Q_P_CURVE_Q1	R/W	2	Q1 on the Q(P) Curve (format, *0.01%Qn)
0x0328	Q_P_CURVE_P1	R/W	2	P1 on the Q(P) Curve (format, *0.1%Pn)
0x0329	Q_P_CURVE_Q2	R/W	2	Q2 on the Q(P) Curve (format, *0.1%Qn)
0x032A	Q_P_CURVE_P2	R/W	2	P2 on the Q(P) Curve (format, *0.1%Pn)
0x032B	Q_P_CURVE_Q3	R/W	2	Q3 on the Q(P) Curve (format, *0.1%Qn)
0x032C	Q_P_CURVE_P3	R/W	2	P3 on the Q(P) Curve (format, *0.1%Pn)
0x032D	Q_P_CURVE_Q4	R/W	2	Q4 on the Q(P) Curve (format, *0.1%Qn)
0x032E	Q_P_CURVE_P4	R/W	2	P4 on the Q(P) Curve (format, *0.1%Pn)
0x035D	Q_V_MIN_COS	R/W	2	Minimum power factor limitation for Q(U) mode (format, *0.01 PF)

Command Code	Command Name	Transaction Type	# of data Bytes	Description
0x035E	Q_V_LOCKIN_P	R/W	2	Lock in power for Q(U) mode (format, *0.1%Pn)
0x035F	Q_V_LOCKOUT_P	R/W	2	Lock out power for Q(U) mode (format, *0.1%Pn)
0x0360	Q_V_CURVE_Q1	R/W	2	Q1 on the Q(U) Curve (format, *0.1%Qn)
0x0361	Q_V_CURVE_V1	R/W	2	V1 on the Q(U) Curve (format, *0.01%Un)
0x0362	Q_V_CURVE_Q2	R/W	2	Q2 on the Q(U) Curve (format, *0.1%Qn)
0x0363	Q_V_CURVE_V2	R/W	2	V2 on the Q(U) Curve (format, *0.01%Un)
0x0364	Q_V_CURVE_Q3	R/W	2	Q3 on the Q(U) Curve (format, *0.1%Qn)
0x0365	Q_V_CURVE_V3	R/W	2	V3 on the Q(U) Curve (format, *0.01%Un)
0x0366	Q_V_CURVE_Q4	R/W	2	Q4 on the Q(U) Curve (format, *0.1%Qn)
0x0367	Q_V_CURVE_V4	R/W	2	V4 on the Q(U) Curve (format, *0.01%Un)
0x03A0	P_V_CURVE_P1	R/W	2	P1 on the P(U) Curve (format, *0.1%Pn)
0x03A1	P_V_CURVE_V1	R/W	2	V1 on the P(U) Curve (format, *0.01%Un)
0x03A2	P_V_CURVE_P2	R/W	2	P2 on the P(U) Curve (format, *0.1%Pn)
0x03A3	P_V_CURVE_V2	R/W	2	V2 on the P(U) Curve (format, *0.01%Un)
0x03A4	P_V_CURVE_P3	R/W	2	P3 on the P(U) Curve (format, *0.1%Pn)
0x03A5	P_V_CURVE_V3	R/W	2	V3 on the P(U) Curve (format, *0.01%Un)
0x03A6	P_V_CURVE_P4	R/W	2	P4 on the P(U) Curve (format, *0.1%Pn)

Command Code	Command Name	Transaction Type	# of data Bytes	Description
0x03A7	P_V_CURVE_V4	R/W	2	V4 on the P(U) Curve (format, *0.01%Un)
0x03D9	UVRT_VOLT1	R/W	2	V1 on the UVRT Curve (format, *0.01%Un)
0x03DA	UVRT_TIME1	R/W	2	T1 on the UVRT Curve (format, *0.01sec)
0x03DB	UVRT_VOLT2	R/W	2	V2 on the UVRT Curve (format, *0.01%Un)
0x03DC	UVRT_TIME2	R/W	2	T2 on the UVRT Curve (format, *0.01sec)
0x03DD	UVRT_VOLT3	R/W	2	V3 on the UVRT Curve (format, *0.01%Un)
0x03DE	UVRT_TIME3	R/W	2	T3 on the UVRT Curve (format, *0.01sec)
0x03DF	UVRT_VOLT4	R/W	2	V4 on the UVRT Curve (format, *0.01%Un)
0x03E0	UVRT_TIME4	R/W	2	T4 on the UVRT Curve (format, *0.01sec)
0x03E1	UVRT_VOLT5	R/W	2	V5 on the UVRT Curve (format, *0.01%Un)
0x03E2	UVRT_TIME5	R/W	2	T5 on the UVRT Curve (format, *0.01sec)
0x03E3	UVRT_VOLT6	R/W	2	V6 on the UVRT Curve (format, *0.01%Un)
0x03E4	UVRT_TIME6	R/W	2	T6 on the UVRT Curve (format, *0.01sec)
0x03E5	UVRT_VOLT7	R/W	2	V7 on the UVRT Curve (format, *0.01%Un)
0x03E6	UVRT_TIME7	R/W	2	T7 on the UVRT Curve (format, *0.01sec)
0x0468	OVRT_VOLT1	R/W	2	V1 on the OVRT Curve (format, *0.01%Un)
0x0469	OVRT_TIME1	R/W	2	T1 on the OVRT Curve (format, *0.01sec)

Command Code	Command Name	Transaction Type	# of data Bytes	Description
0x046A	OVRT_VOLT2	R/W	2	V ₂ on the OVRT Curve (format, *0.01%Un)
0x046B	OVRT_TIME2	R/W	2	T ₂ on the OVRT Curve (format, *0.01sec)
0x046C	OVRT_VOLT3	R/W	2	V ₃ on the OVRT Curve (format, *0.01%Un)
0x046D	OVRT_TIME3	R/W	2	T ₃ on the OVRT Curve (format, *0.01sec)
0x046E	OVRT_VOLT4	R/W	2	V ₄ on the OVRT Curve (format, *0.01%Un)
0x046F	OVRT_TIME4	R/W	2	T ₄ on the OVRT Curve (format, *0.01sec)
0x0470	OVRT_VOLT5	R/W	2	V ₅ on the OVRT Curve (format, *0.01%Un)
0x0471	OVRT_TIME5	R/W	2	T ₅ on the OVRT Curve (format, *0.01sec)
0x0472	OVRT_VOLT6	R/W	2	V ₆ on the OVRT Curve (format, *0.01%Un)
0x0473	OVRT_TIME6	R/W	2	T ₆ on the OVRT Curve (format, *0.01sec)
0x0474	OVRT_VOLT7	R/W	2	V ₇ on the OVRT Curve (format, *0.01%Un)
0x0475	OVRT_TIME7	R/W	2	T ₇ on the OVRT Curve (format, *0.01sec)
0x0609	LFSMO_FREQ_START	R/W	2	Start frqncy of LFSM-O (format, *0.01Hz)
0x060A	LFSMO_FREQ_STOP	R/W	2	Stop frqncy of LFSM-O (format, *0.01Hz)
0x060B	LFSMO_STOP_DLY	R/W	2	Stop deay of LFSM-O (format, *0.01sec)
0x060C	LFSMO_DROOP_RATE	R/W	2	Droop rate of LFSM-O (format, *0.1%)
0x060D	LFSMO_ACTIVE_DLY	R/W	2	Activation delay of LFSM-O (format, *0.01%)

Command Code	Command Name	Transaction Type	# of data Bytes	Description
0x060E	LFSMU_FREQ_START	R/W	2	Start frqncy of LFSM-U (format, *0.01Hz)
0x0611	LFSMU_DROOP_RATE	R/W	2	Droop rate of LFSM-U (format, *0.1%)
0x0612	LFSMU_ACTIVE_DLY	R/W	2	Activation delay of LFSM-U (format, *0.01sec)
0x0613	LFSM_P_REF	R/W	2	LFSM Pref setting (0 : Pn ; 1 : PM)
0x0640	UVP1_VOLT	R/W	2	1st-level undervoltage protection (V) (format, *0.01%Un)
0x0641	UVP1_TIME	R/W	2	1st-level undervoltage trip time (T) (format, *0.01sec)
0x0642	UVP2_VOLT	R/W	2	2nd-level undervoltage protection (V) (format, *0.01%Un)
0x0643	UVP2_TIME	R/W	2	2nd-level undervoltage trip time (T) (format, *0.01sec)
0x0644	UVP3_VOLT	R/W	2	3rd-level undervoltage protection (V) (format, *0.01%Un)
0x0645	UVP3_TIME	R/W	2	3rd-level undervoltage trip time (T) (format, *0.01sec)
0x0646	OVP1_VOLT	R/W	2	1st-level overvoltage protection (V) (format, *0.01%Un)
0x0647	OVP1_TIME	R/W	2	1st-level overvoltage trip time (T) (format, *0.01sec)
0x0648	OVP2_VOLT	R/W	2	2nd-level overvoltage protection (V) (format, *0.01%Un)
0x0649	UVRT_TIME6	R/W	2	2nd-level overvoltage trip time (T) (format, *0.01sec)
0x064A	OVP3_VOLT	R/W	2	3rd-level overvoltage protection (V) (format, *0.01%Un)
0x064B	OVP3_TIME	R/W	2	3rd-level overvoltage trip time (T) (format, *0.01sec)
0x064C	UFP1_FREQ	R/W	2	1st-level underfrequency threshold (Hz) (format, *0.01%Un)

Command Code	Command Name	Transaction Type	# of data Bytes	Description
0x064D	UFP1_TIME	R/W	2	1st-level underfrequency trip time (T) (format, *0.01sec)
0x064E	UFP2_FREQ	R/W	2	2nd-level underfrequency threshold (Hz) (format, *0.01%Un)
0x064F	UFP2_TIME	R/W	2	2nd-level underfrequency trip time (T) (format, *0.01sec)
0x0650	UFP3_FREQ	R/W	2	3rd-level underfrequency threshold (Hz) (format, *0.01%Un)
0x0651	UFP3_TIME	R/W	2	3rd-level underfrequency trip time (T) (format, *0.01sec)
0x0652	OFP1_FREQ	R/W	2	1st-level overfrequency threshold (Hz) (format, *0.01%Un)
0x0653	OFP1_TIME	R/W	2	1st-level overfrequency trip time (T) (format, *0.01sec)
0x0654	OFP2_FREQ	R/W	2	2nd-level overfrequency threshold (Hz) (format, *0.01%Un)
0x0655	OFP2_TIME	R/W	2	2nd-level overfrequency trip time (T) (format, *0.01sec)
0x0656	OFP3_FREQ	R/W	2	3rd-level overfrequency threshold (Hz) (format, *0.01%Un)
0x0657	OFP3_TIME	R/W	2	3rd-level overfrequency trip time (T) (format, *0.01sec)
0x0658	OVP10MIN_VOLT	R/W	2	10-minute average overvoltage protection point (format, *0.01%Un)
0x0659	ROCOF_SLOPE	R/W	2	Slope setting of ROCOF (format, *0.1Hz/sec)
0x065A	ROCOF_WINDOW_TIME	R/W	2	Window time of ROCOF (format, *0.01sec)
0x0800	EVENTLOG_1	R	2	Most recent 1st event log record
0x0801	EVENTLOG_2	R	2	Most recent 2nd event log record
0x0802	EVENTLOG_3	R	2	Most recent 3rd event log record

Command Code	Command Name	Transaction Type	# of data Bytes	Description
0x0803	EVENTLOG_4	R	2	Most recent 4th event log record
0x0804	EVENTLOG_5	R	2	Most recent 5th event log record
0x0810	ENTER_PWD	W	6	Password enter for DSO
0x0811	SET_PWD_KEY	R/W	2	Unlock/lock status reporting and password setting
0x0910	CLEAR_LOG	W	2	Clear recored logs

NOTE :

- Before setting POUT_USER_CMD (0x0150), please utilize the SETTING_UBLOCK command to unlock. Refer to section 6.1.4.3 for detailed instructions.
- Commands with * at the end support the EEP_OFF and EEP_CONFIG functions, which define the EEPROM write strategy. Please refer to SYSTEM_CONFIG (0x00C2) for detailed information.

Data conversion:

Actual Value = Communication Write/Read Value × Factor Value, where the factor value is used for both writing and reading during communication for data conversion.

Each command may have a different factor value, which can be found in the command list or retrieved from the SCALING_FACTOR (0x00C0) command.

Example 1: If the communication read value for the READ_VOUT command is 0x0960 (hexadecimal), and the factor value for the command is 0.01:
Actual Value = 0x0960 (hex) → 2400 (decimal) × 0.01 = 24V.

Example 2: The PF_SET (0x02EE) command supports both lagging and leading power factor values. The corresponding reactive power will be positive or negative accordingly.
The conversion formula between PF_SET and PF is:
Q > 0 (lagging) : PF_SET = PF × 100
Q < 0 (leading) : PF_SET = -PF × 100
If PF = 0.9, for example, then PF_SET = 90 → communication setting = 0x005A.

◎FAULT_STATUS(0x0040):

High byte	Bit 7	Bit 6	Bit 5	Bit 4	Bit 3	Bit 2	Bit 1	Bit 0
Definition	---	---	---	---	---	---	UTP	HV_OVP
Low byte	Bit 7	Bit 6	Bit 5	Bit 4	Bit 3	Bit 2	Bit 1	Bit 0
Definition	HI_TEMP	OP_OFF	AC_FAIL	SHORT	OLP	OVP	OTP	FAN_FAIL

Low byte :

Bit 0 FAN_FAIL : Fan locked flag

0 = Fan working normally
1 = Fan locked

Bit 1 OTP : Over temperature protection

0 = Internal temperature normal
1 = Internal temperature too high

Bit 2 OVP : DC over voltage protection

0 = DC voltage normal
1 = DC over voltage protected

Bit 3 OLP : DC over current protection

0 = DC current normal
1 = DC over current protected

Bit 4 SHORT : Short circuit protection

0 = Shorted circuit do not exist
1 = Shorted circuit protected

Bit 5 AC_FAIL : AC abnormal flag

0 = AC range normal
1 = AC range abnormal

Bit6 OP_OFF : DC status

0 = DC turned on
1 = DC turned off

Bit7 HI_TEMP : Internal high temperature alarm

0 = Internal temperature normal
1 = Internal temperature high

High byte :

Bit 0 HV_OVP : HV over voltage protection

0 = HV voltage normal
1 = HV over voltage protected

Bit 1 UTP : Under temperature protection

0 = Internal temperature normal
1 = Internal temperature too low

◎MFR_ID_B0B5(0x0080) is the first 6 codes of the manufacturer's name (ASCII);
MFR_ID_B6B11(0x0083) is the last 6 codes of the manufacturer's name (ASCII)

EX: manufacturer's name is MEANWELL→MFR_ID_B0B5 is MEANWE;
MFR_ID_B6B11 is LL

MFR_ID_B0B5					
Byte 0	Byte 1	Byte 2	Byte 3	Byte 4	Byte 5
0x4D	0x45	0x41	0x4E	0x57	0x45

MFR_ID_B6B11					
Byte 0	Byte 1	Byte 2	Byte 3	Byte 4	Byte 5
0x4C	0x4C	0x20	0x20	0x20	0x20

◎MFR_MODEL_B0B5 (0x0082) is the first 6 codes of the manufacturer's model name (ASCII);
MFR_MODEL_B6B11 (0x0083) is the last 6 codes of the manufacturer's model name (ASCII)

EX: Model name is BIC-5K-24→MFR_MODEL_B0B5 is BIC-5K;MFR_MODEL_B6B11 is 24

MFR_MODEL_B0B5					
Byte 0	Byte 1	Byte 2	Byte 3	Byte 4	Byte 5
0x42	0x49	0x43	0x2D	0x35	0x4B

MFR_MODEL_B6B11					
Byte 6	Byte 7	Byte 8	Byte 9	Byte 10	Byte 11
0x2D	0x32	0x34	0x20	0x20	0x20

◎MFR_REVISION_B0B5(0x0084) is the firmware revision (hexadecimal). A range of 0x00(R00.0)~0xFE (R25.4) represents the firmware version of an MCU; 0xFF represents no MCU existed

EX: The supply has two MCUs, the firmware version of the MCU number 1 is version R25.4 (0xFE), the MCU number 2 is version R10.5 (0x69)

Byte 0	Byte 1	Byte 2	Byte 3	Byte 4	Byte 5
0xFE	0x69	0xFF	0xFF	0xFF	0xFF

©MFR_DATE_B0B5(0x0086) is manufacture date (ASCII)

EX: MFR_DATE_B0B5 is 180101, meaning 2018/01/01

Byte 0	Byte 1	Byte 2	Byte 3	Byte 4	Byte 5
0x31	0x38	0x30	0x31	0x30	0x31

©MFR_SERIAL_B0B5(0x0087) and MFR_SERIAL_B6B11(0x0088) are defined as manufacture date and manufacture serial number (ASCII)

EX: The first unit manufactured on 2018/01/01→MFR_SERIAL_B0B5:

180101 ; MFR_SERIAL_B6B11: 000001

MFR_ID_B0B5					
Byte 0	Byte 1	Byte 2	Byte 3	Byte 4	Byte 5
0x31	0x38	0x30	0x31	0x30	0x31

MFR_ID_B6B11					
Byte 6	Byte 7	Byte 8	Byte 9	Byte 10	Byte 11
0x30	0x30	0x30	0x30	0x30	0x31

©CURVE_CONFIG(0x00B4) :

	Bit7	Bit6	Bit5	Bit4	Bit3	Bit2	Bit1	Bit0
High byte	---	---	---	---	---	FVTOE	CVTOE	CCTOE
Low byte	---	STGS	---	---	---	---	CUVS	

Low byte :

Bit 0:1 CUVS : Charge Curve Selection

00 = Customized Charge Curve (default)

01 = Gel Battery

10 = Flooded Battery

11 = LiFeO4 battery Battery

Bit 6 STGS : 2/3 Stage Charge Setting

0 = 3 stage charge (default, CURVE_VBST and CURVE_V FLOAT)

1 = 2 stage charge (only CURVE_VBST)

High byte :

Bit 0 CCTOE : Constant Current Stage Timeout Indication Enable

0 = disabled (default)

1 = enabled

Bit 1 CVTOE : Constant Voltage Stage Timeout Indication Enable

0 = disabled (default)

1 = enabled

Bit 2 FVTOE : Float Voltage Stage Timeout Indication Enable

0 = disabled (default)

1 = enabled

©CHG_STATUS(0x00B8) :

	Bit7	Bit6	Bit5	Bit4	Bit3	Bit2	Bit1	Bit0
High byte	FVTOF	CVTOF	CCTOF	---	---	---	---	---
Low byte	---	---	---	---	FVM	CVM	CCM	FULLM

Low byte :

Bit 0 FULLM : Fully Charged Mode Status

0 = NOT fully charged
1 = fully charged

Bit 1 CCM : Constant Current Mode Status

0 = the charger NOT in constant current mode
1 = the charger in constant current mode

Bit 2 CVM : Constant Voltage Mode Status

0 = the charger NOT in constant voltage mode
1 = the charger in constant voltage mode

Bit 3 FVM : Float Mode Status

0 = the charger NOT in float mode
1 = the charger in float mode

High byte :

Bit 5 CCTOF : Time Out Flag of Constant Current Mode

0 = NO time out in constant current mode
1 = constant current mode timed out

Bit 6 CVTOF : Time Out Flag of Constant Voltage Mode

0 = NO time out in constant voltage mode
1 = constant voltage mode timed out

Bit 7 FVTOF : Time Out Flag of Float Voltage Mode

0 = NO time out in float mode
1 = float mode timed out

©SCALING_FACTOR(0x00C0) :

Byte 5	Bit 7	Bit 6	Bit 5	Bit 4	Bit 3	Bit 2	Bit 1	Bit 0
Definition	---				---			
Byte 4	Bit 7	Bit 6	Bit 5	Bit 4	Bit 3	Bit 2	Bit 1	Bit 0
Definition	---				Frequency Factor			
Byte 3	Bit 7	Bit 6	Bit 5	Bit 4	Bit 3	Bit 2	Bit 1	Bit 0
Definition	Watt Factor				IIN Factor / IAC Factor			
Byte 2	Bit 7	Bit 6	Bit 5	Bit 4	Bit 3	Bit 2	Bit 1	Bit 0
Definition	CURVE_TIMEOUT Factor				TEMPERATURE_1 Factor			
Byte 1	Bit 7	Bit 6	Bit 5	Bit 4	Bit 3	Bit 2	Bit 1	Bit 0
Definition	FAN_SPEED Factor				VIN Factor / VAC Factor			
Byte 0	Bit 7	Bit 6	Bit 5	Bit 4	Bit 3	Bit 2	Bit 1	Bit 0
Definition	IOUT Factor / IDC Factor				VOUT Factor / VDC Factor			

byte 0 :

Bit 0 : 3 VOUT Factor/VDC Factor : The factor value for DC voltage-related commands, such as VOUT_SET

0x0=DC voltage relevant commands not supported
0x1~0x3=Not in use, reserved (default 0)
0x4=0.001
0x5=0.01
0x6=0.1
0x7=1.0
0x8=10
0x9=100

Bit 4 : 7 IOUT Factor/IDC Factor : The factor value for DC current-related commands, such as READ_IOUT

0x0=DC current relevant commands not supported
0x1~0x3=Not in use, reserved (default 0)
0x4=0.001
0x5=0.01
0x6=0.1
0x7=1.0
0x8=10
0x9=100

byte 1 :

Bit 0 : 3 **VIN Factor/VAC Factor** : The factor value of READ_VIN

0x0=AC voltage relevant commands not supported
0x1~0x3=Not in use, reserved (default 0)
0x4=0.001
0x5=0.01
0x6=0.1
0x7=1.0
0x8=10
0x9=100

Bit 4 : 7 **FAN_SPEED Factor** : The factor value of READ_FAN_SPEED_1/2

0x0= Fan speed relevant commands not supported
0x1~0x3=Not in use, reserved (default 0)
0x4=0.001
0x5=0.01
0x6=0.1
0x7=1.0
0x8=10
0x9=100

byte 2 :

Bit 0 : 3 **TEMPERATURE_1 Factor** : The factor value of READ_TEMPERATURE_1

0x0=Internal temperature relevant commands not supported
0x1~0x3=Not in use, reserved (default 0)
0x4=0.001
0x5=0.01
0x6=0.1
0x7=1.0
0x8=10
0x9=100

Bit 4 : 7 **CURVE_TIMEOUT Factor** : The Factor of CC/CV/Float timeout

0x0=CURVE_TIMEOUT relevant commands not supported
0x1~0x3=Not in use, reserved (default 0)
0x4=0.001
0x5=0.01
0x6=0.1
0x7=1.0
0x8=10
0x9=100

byte 3 :

Bit 0 : 3 **IIN Factor/IAC Factor** : The Factor of input current/AC current

0x0=AC input current relevant commands not supported
0x1~0x3=Not in use, reserved (default 0)
0x4=0.001
0x5=0.01
0x6=0.1
0x7=1.0
0x8=10
0x9=100

Bit 4 : 7 **Watt Factor** : The Factor of output AC wattage
(Power/Reactive/VA)

0x0=AC wattage relevant commands not supported
0x1~0x3=Not in use, reserved (default 0)
0x4=0.001
0x5=0.01
0x6=0.1
0x7=1.0
0x8=10
0x9=100

byte 4 :

Bit 0 : 3 **Frequency Factor** : The Factor of Frequency

0x0=Frequency relevant commands not supported
0x1~0x3=Not in use, reserved (default 0)
0x4=0.001
0x5=0.01
0x6=0.1
0x7=1.0
0x8=10
0x9=100

◎SYSTEM_STATUS(0x00C1):

High byte	Bit 7	Bit 6	Bit 5	Bit 4	Bit 3	Bit 2	Bit1	Bit 0
Definition	---	---	---	---	---	---	---	---
Low byte	Bit 7	Bit 6	Bit 5	Bit 4	Bit 3	Bit 2	Bit1	Bit 0
Definition	---	EEPER	INITIAL_STATE	---	---	DA_OK	DC_OK	M/S

Low byte :

Bit 0 M/S : Parallel mode status

- 0 = Current device is Slave
- 1 = Current device is Master

Bit 1 DC_OK : Secondary DD output voltage status

- 0 = Secondary DD output voltage status TOO LOW
- 1 = Secondary DD output voltage status NORMAL

Bit 2 DA_OK : Primary DA status

- 0 = Primary DA OFF or abnormal
- 1 = Primary DA ON normally

Bit 5 INITIAL_STATE : Device initialized status

- 0 = In initialization status
- 1 = NOT in initialization status

Bit 6 EEPER : EEPROM data access error

- 0 = EEPROM data access normal
- 1 = EEPROM data access error
- ※ When an EEPROM data access error occurs, the device shuts down and then entering protection mode with the LED indicator off. It only can be recovered after the EEPROM error condition is resolved.

◎SYSTEM_CONFIG(0x00C2):

High byte	Bit 7	Bit 6	Bit 5	Bit 4	Bit 3	Bit 2	Bit1	Bit 0
Definition	---	---	---	---	---	EEP_OFF	EEP_CONFIG	
Low byte	Bit 7	Bit 6	Bit 5	Bit 4	Bit 3	Bit 2	Bit1	Bit 0
Definition	---	---	---	---	---	OPERATION_INIT		CAN_CTRL

Low byte :

Bit 0 CAN_CTRL : CANBus communication control status

- 0 = The output voltage/current defined by control over SVR (default)
- 1 = The output voltage, current, ON/OFF control defined by control over CAN bus (VOUT_SET, IOUT_SET, OPERATION)

Bit 1 : 2 OPERATION_INIT : Pre-set value of power on operation command

- 0b00 = Power OFF, pre-set 0x00(OFF)
- 0b01 = Power ON, pre-set 0x01(ON) (default)
- 0b10 = Pre-set is previous set value
- 0b11 = not used, reserved

High Byte

Bit 0 : 1 Bit 0 : 1 EEP_CONFIG : EEPROM Configuration

- 00 : Immediate. Changes to parameters are written to EEPROM immediately (default)
- 01 : 1 minute delay. Write changes to EEPROM if all parameters remain unchanged for 1 minute
- 10 : 10 minute delay. Write changes to EEPROM if all parameters remain unchanged for 10 minutes
- 11 : Reserved

Bit 2 EEP_OFF : EEPROM storage function ON/OFF

- 0 : Enable. Parameters to be saved into EEPROM (default)
- 1 : Disable. Parameters NOT to be saved into EEPROM

◎INV_OPERATION(0x0100) :

High byte	Bit 7	Bit 6	Bit 5	Bit 4	Bit 3	Bit 2	Bit1	Bit 0
Definition	---	---	---	---	---	---	---	---
Low byte	Bit 7	Bit 6	Bit 5	Bit 4	Bit 3	Bit 2	Bit1	Bit 0
Definition	---	---	---	CHG_FIRST	GRID_EN	CHG_EN	---	---

Low byte:

Bit 2 CHG_EN : Charger Mode enabling
 0 = Charger Mode disabled (default)
 1 = Charger Mode enabled

Bit 3 GRID_EN : Grid-tied Mode enabling
 0 = Grid-tied Mode disabled (default)
 1 = Grid-tied Mode enabled

Bit 4 CHG_FIRST : Charger first or not in Grid-tied + Charger Mode
 0 = Grid first (default)
 1 = Charging first

NOTE: BIC Mode is enabled when both CHG_EN and GRID_EN bits are logic 0.

◎INV_STATUS(0x011D) :

	Bit 7	Bit 6	Bit 5	Bit 4	Bit 3	Bit 2	Bit1	Bit 0
High byte	---	---	---	---	---	---	---	---
Low byte	Bat_H_ALM	Bat_Low_ALM	---	---	CHG_ON	UTI_OK	---	---

Low byte:

Bit 2 UTI_OK : Utility Power Exist
 0 = Utility power failure
 1 = Utility Power normal

Bit 3 CHG_ON : Charger status
 0 = Charger OFF
 1 = Charger ON

Bit6 Bat_Low_ALM : Battery low alarm
 0 = Battery low alarm is NOT triggered
 1 = Battery low alarm is triggered

Bit7 BAT_H_ALM: Battery high alarm
 0 = Battery high alarm is NOT triggered
 1 = Battery high alarm is triggered

◎BIDIR_CONFIG(0x0143):

High byte	Bit 7	Bit 6	Bit 5	Bit 4	Bit 3	Bit 2	Bit1	Bit 0
Definition	---	---	---	---	---	---	---	---
Low byte	Bit 7	Bit 6	Bit 5	Bit 4	Bit 3	Bit 2	Bit1	Bit 0
Definition	---	---	---	---	---	---	---	MODE

Low byte :

Bit 0 MODE: Bidirectional mode configuration
 0 = Bi-direction auto-detect mode. DIR_CTRL and C/D control (analog) UN-controllable (default)
 1 = Bi-direction battery mode. DIR_CTRL and C/D control (analog) controllable

◎GRID_ALARM(0x0205) :

Byte 3	Bit 7	Bit 6	Bit 5	Bit 4	Bit 3	Bit 2	Bit 1	Bit 0
Definition	---	---	---	---	---	---	---	---
Byte 2	Bit 7	Bit 6	Bit 5	Bit 4	Bit 3	Bit 2	Bit 1	Bit 0
Definition	---	---	---	---	---	---	---	---
Byte 1	Bit 7	Bit 6	Bit 5	Bit 4	Bit 3	Bit 2	Bit 1	Bit 0
Definition	---	COMM_ERR	EEPER	HW_ERR	FAN_LOCK	UTP	OTP	HV_OVP
Byte 0	Bit 7	Bit 6	Bit 5	Bit 4	Bit 3	Bit 2	Bit 1	Bit 0
Definition	BAT_UVP	BAT_OVP	---	ROCOF	GRID_UFP	GRID_OFP	GRID_UVP	GRID_OVP

Byte 0

Bit 0 GRID_OVP : Overvoltage protection in grid-connected mode
 0 = AC voltage normal
 1 = AC over-voltage protected

Bit 1 GRID_UVP : Undervoltage protection in grid-connected mode
 0 = AC voltage normal
 1 = AC under-voltage protected

Bit 2 GRID_OFP : Overfrequency protection in grid-connected mode
 0 = AC frequency normal
 1 = AC over-frequency protected

Bit 3 GRID_UFP : Underfrequency protection in grid-connected mode
 0 = AC frequency normal
 1 = AC under-frequency protected

- Bit 4** **ROCOF** : ROCOF protection in grid-connected mode
 0 = ROCOF normal
 1 = ROCOF abnormal protected
- Bit 6** **BAT_OVP** : Battery overvoltage protection
 0 = battery voltage normal
 1 = Battery overvoltage protected
- Bit 7** **BAT_UVP** : Battery undervoltage protection
 0 = battery voltage normal
 1 = Battery undervoltage protected
- Byte 1**
- Bit 0** **HV_OVP** : HV over voltage protection
 0 = HV voltage normal
 1 = HV over voltage protected
- Bit 1** **OTP** : Over temperature protection
 0 = Internal temperature normal
 1 = Internal temperature too high
- Bit 2** **UTP** : Under temperature protection
 0 = Internal temperature normal
 1 = Internal temperature too low
- Bit 3** **FAN_LOCK** : Fan locked flag
 0 = Fan working normally
 1 = Fan locked
- Bit 4** **HW_ERROR** : Hardware error
 0 = hardware normal
 1 = hardware abnormal protected
- Bit 5** **EEPER** : EEPROM data access error
 0 = EEPROM data access normal
 1 = EEPROM data access error

- Bit 6** **COMM_ERR** : Internal communication access error
 0 = Internal communication access normal
 1 = Internal communication access error

◎THROT_SRC(0x0248) :

Byte 3	Bit 7	Bit 6	Bit 5	Bit 4	Bit 3	Bit 2	Bit 1	Bit 0
Definition	---	---	---	---	---	---	---	---
Byte 1	Bit 7	Bit 6	Bit 5	Bit 4	Bit 3	Bit 2	Bit 1	Bit 0
Definition	---	---	---	---	---	---	---	---
Byte 1	Bit 7	Bit 6	Bit 5	Bit 4	Bit 3	Bit 2	Bit 1	Bit 0
Definition	---	PF_P	PF_SET	Q_P	Q_U	Q_SET	P_U	P_SET
Byte 0	Bit 7	Bit 6	Bit 5	Bit 4	Bit 3	Bit 2	Bit 1	Bit 0
Definition	---	DERATED	LFSMU	LFSMO	---	---	UVRT	OVRT

Byte 0

- Bit 0** **OVRT** : OVRT
 0 = the output control is not limited by OVRT
 1 = the output control is limited by OVRT
- Bit 1** **UVRT** : UVRT
 0 = the output control is not limited by UVRT
 1 = the output control is limited by UVRT
- Bit 4** **LFSMO** : LFSM-O
 0 = the output control is not limited by LFSM-O
 1 = the output control is limited by LFSM-O
- Bit 5** **LFSMU** : LFSM-U
 0 = the output control is not limited by LFSM-U
 1 = the output control is limited by LFSM-U
- Bit 6** **DERATED** : DERATED
 0 = the output control is not limited by DERATED
 1 = the output control is limited by DERATED

Byte 1

Bit 0 P_SET : Maximum active power output setting

0 = the output control is not limited by P_SET

1 = the output control is limited by P_SET

Bit 1 P_U : P(U) Curve

0 = the output control is not limited by P(U)

1 = the output control is limited by P(U)

Bit 2 Q_SET : Maximum reactive

0 = the output control is not limited by Q_SET

1 = the output control is limited by Q_SET

Bit 3 Q_U : Q(U) curve

0 = the output control is not limited by Q(U)

1 = the output control is limited by Q(U)

Bit 4 Q_P : Q(P) curve

0 = the output control is not limited by Q(P)

1 = the output control is limited by Q(P)

Bit 5 PF_SET : cosφ set point

0 = the output control is not limited by PF_SET

1 = the output control is limited by PF_SET

Bit 6 PF_P : cosφ(P) curve

0 = the output control is not limited by PF_P

1 = the output control is limited by PF_P

©SAFTY_FUNC_CONFIG(0x02E4):

High byte	Bit 7	Bit 6	Bit 5	Bit 4	Bit 3	Bit 2	Bit 1	Bit 0
Definition	---	---	---	---	---	---	ANTI_ISL	NS_PROTECT
Low byte	Bit 7	Bit 6	Bit 5	Bit 4	Bit 3	Bit 2	Bit 1	Bit 0
Definition	---	ROCOF	LFSMU	LFSMO	---	---	OVRT	UVRT

Low byte :

Bit 0 UVRT : UVRT enabling

0 = disabled

1 = enabled

Bit 1 OVRT : OVRT enabling

0 = disabled

1 = enabled

Bit 4 LFSMO : LFSM-O enabling

0 = disabled

1 = enabled

Bit 5 LFSMU : LFSM-U enabling

0 = disabled

1 = enabled

Bit 6 RPCPF : ROCOF protection enabling

0 = disabled

1 = enabled

High byte :

Bit 0 NS_PROTECT : NS protection enabling

0 = disabled

1 = enabled

Bit 1 ANTI_ISL : Active anti-islanding enabling (SFS)

0 = disabled

1 = enabled

©CTRL_MODE(0x02E8) :

High byte	Bit 7	Bit 6	Bit 5	Bit 4	Bit 3	Bit 2	Bit 1	Bit 0
Definition	---	---	---	---	---	---	---	CTRL_STORAGE_CFG
Low byte	Bit 7	Bit 6	Bit 5	Bit 4	Bit 3	Bit 2	Bit 1	Bit 0
Definition	Q_CTRL_MODE				---	---	---	PU_EN

Low byte :

Bit 0 PU_EN : P(U) enabling

0 = disabled (default)

1 = enabled

Bit 4-7 Q_CTRL_MODE : Reactive power control mode setting

0000 = reactive power control mode dialbed

0001 = Q setpint mode

0010 = Q(U) mode

0011 = Q(P) mode

0100 = Cos φ setpint (default)

0101 = Cos φ(P) mode

High byte :

Bit 0 CTRL_STORAGE_CFG : EEPROM stogarge configriaton for

GRID_TIE_REMOTE / P_SET / Q_SET / PF_SET

0 = Do not store command parameters (default)

1 = Store command parameters

(GRID_TIE_REMOTE / P_SET / Q_SET / PF_SET) into the EEPROM

6.1.4 CAN Bus Communication Examples

The following provides examples of command sending and data reading for the CAN bus protocol.

6.1.4.1 Sending command

Set the address 00 unit in communication mode, the master set CAN_CTRL bit in the SYSTEM_CONFIG (0x00C2) command to "logic 1".

CANID	DLC(data length)	Command Code	Parameter
0xC0300	0x04	0xC200	0x0300

Command code : 0x00C2 (SYSTEM_CONFIG) → 0xC2 (Lo) + 0x00 (Hi)

Data : Data : Low bytes: changes to 0b0110 → 0x03 ;

High bytes : remains at 0b0000 → 0x00

Low byte :

Bit 0 CAN_CTRL : CANBus communication control status

0 = The output voltage/current defined by control over SVR

1 = The output voltage, current, ON/OFF control defined by control over CAN bus (VOUT_SET, IOOUT_SET, OPERATION)

Bit 1 : 2 OPERATION_INIT : Pre-set value of power on operation command

0b00 = Power OFF, pre-set 0x00(OFF)

0b01 = Power ON, pre-set 0x01(ON)

0b10 = Pre-set is previous set value

0b11 = not used, reserved

6.1.4.2 Reading data or status

The master reads the READ_VIN command from the unit with address "01".

CAN ID	DLC(data length)	Command Code
0xC0300	0x02	0x5000

Command code : 0x0050 (READ_VIN) → 0x50 (Lo) + 0x00 (Hi)

The unit with address "01" returns data below :

CAN ID	DLC(data length)	Command Code	Command Code
0xC0300	0x04	0x5000	0xFC08

Parameters : 0xFC (Lo) + 0x08(Hi) → 0x08FC → 2300
→ 2300 x 0.1(F) = 230Vac

NOTE : Conversion factor for READ_VIN is 0. 1.

6.1.4.3 POUT_USER_CMD(0x0150) Settngins for User

To avoid improper output power configurations in Grid-tied Mode, the POUT_USER_CMD (0x0150) register requires a different setup process. It must be unlocked via the SETTING_UNLOCK (0x00CF) command prior to modification.

- Unlock password
SETTING_UNLOCK(0x00CF)

CANID	DLC(data length)	Command Code	Data
0x00C0300	0x04	0xCF00	0x574D

- Set POUT_USER_CMD
POUT_USER_CMD(0x0150)

CANID	DLC(data length)	Command Code	Data
0x00C0300	0x04	0x5001	0x8813

6.1.4.4 Event Logs

6.1.4.4.1 Read Event Logs

The event log commands (0x0800 – 0x0804) record significant events that occurred in the device. The errors information is divided into three categories : grid-related, DC-related, and others, and is intended to support troubleshooting and fault analysis.

Type	Event	Data (Decimal)	Data (Hexadecimal)
GRID	GRID_OVP (Grid Over-Voltage Protection)	1001	0x03E9
	GRID_UVP (Grid Under-Voltage Protection)	1002	0x03EA
	GRID_OFP (Grid Over-Frequency Protection)	1003	0x03EB
	GRID_UFP (Grid Under-Frequency Protection)	1004	0x03EC
	GRID_ROCOF (Grid Rate-Of-Change-Of-Frequency Protection)	1009	0x03F1
	GRID_DISC (Grid Disconnection)	1011	0x03F3
DC	VBUS_OVP (Internal DC bus Over-Voltage Protection)	3001	0x0BB9
	VBUS_UVP (Internal DC bus Under-Voltage Protection)	3002	0x0BBA
	DC_OVP (DC end Over-Voltage Protection)	3003	0x0BBB
	DC_UVP (DC end Under-Voltage Protection)	3004	0x0BBC
	DC_OLP (DC end Over-Load Protection)	3005	0x0BBD
	DC_SCP (DC end Short-Circuit Protection)	3006	0x0BBE
	CHG_OTE (Charge time out)	3008	0x0BC0
	DD FAIL (Internal protection triggered at the secondary end)	3012	0x0BC4
OTHER	OTP (Over-Temperature Protection)	4001	0x0FA1
	UTP (Under-Temperature Protection)	4002	0x0FA2
	FANLOCK	4004	0x0FA4
	HW_ERROR (Internal hardware error)	4005	0x0FA5

Type	Event	Data (Decimal)	Data (Hexadecimal)
OTHER	COMM_ERROR (Internal communication error)	4006	0x0FA6
	EEP_ERROR (EEPROM access error)	4007	0x0FA7
	RELAY_ERROR	4008	0x0FA8

NOTE : 1.This device can store up to five event records. The most recent event is recorded in EVENTLOG_1 (0x0800), and the remaining events are shifted accordingly from EVENTLOG_2 (0x0801) to EVENTLOG_5 (0x0804). When more than five events are recorded, the oldest record is removed. For example :

	T1	T2	T3	T4	T5	T6 (latest)
Event	GRID_OVP	GRID_OFF	GRID_DISC	OTP	DC_UVP	FANLOCK
EVENTLOG_1 (0x0800)	1001	1003	1011	4001	3004	4004
EVENTLOG_2 (0x0801)	0	1001	1003	1011	4001	3004
EVENTLOG_3 (0x0802)	0	0	1001	1003	1011	4001
EVENTLOG_4 (0x0803)	0	0	0	1001	1003	1011
EVENTLOG_5 (0x0804)	0	0	0	0	1001	1003
Description	GRID_OVP is stored in EVENTLOG_1.	GRID_OFF is stored in EVENTLOG_1. GRID_OVP shifted to EVENTLOG_2	GRID_DISC is stored in EVENTLOG_1. GRID_OVP shifted to EVENTLOG_3	OTP is stored in EVENTLOG_1. GRID_OVP shifted to EVENTLOG_4	DC_UVP is stored in EVENTLOG_1. GRID_OVP shifted to EVENTLOG_5.	FANLOCK is stored in EVENTLOG_1. GRID_OVP is removed from the EEPROM.

2.Event log data is stored in the EEPROM and is retained after power-off. To clear the event logs, please refer to Section 6.1.4.4.2 Clear Event Log.

6.1.4.4.2 Clear Event Logs

Event log clearing is supported through the CLEAR_LOG (0x0910) command. The steps for removing the stored logs are provided below:

CANID	DLC(data length)	Command Code	Data
0x00C0300	0x04	0x1009	0xAA00

6.1.4.5 Password Setting for the Grid Connection Parameters for DSO

According to the EN 50549 standard, grid-connection parameters are accessible only to the DSO and must be managed under an authorization control mechanism. Registers ranging from 0x0202 (AC_TYPE) to 0x065A (ROCOF_WINDOW_TIME) can only be configured after the device is unlocked.

The default password is "000000" (string) or the unlocked state. When the password remains at its default value, all grid-connection parameters can be modified freely without entering the password. The current lock status can be read from SET_PWD_KEY (0x0811).

Read value from SET_PWD_KEY(0x0811)	Status
0x0000	Unlocked or no password
0x00FE	Locked or incorrect password
0x0055	Non-default password. A password for unlock is required

● Password Unlock Procedure

The following example illustrates how to unlock the device when the password is set to **765432** (string).

① Enter the password to ENTER_PWD (0x0810)

CAN ID	DLC(data length)	Command Code	Data
0x00C0300	0x04	0x1008	0x373635343332

② Read the SET_PWD_KEY (0x0823) status

CAN ID	DLC(data length)	Command Code
0x00C0300	0x2	0x1108

If the response returns 0x0000, it indicates that the password has been successfully entered, and the grid connection parameters can now be modified

CAN ID	DLC(data length)	Command Code	Data
0x00C0200	0x04	0x1108	0x0000

- ③ Lock the device manually (or wait 5 minutes for automatic locking)

CAN ID	DLC(data length)	Command Code	Data
0x00C0300	0x04	0x1108	0x5500

NOTE : When the BIC-5K is in the unlocked state, receiving any new grid-connection parameter change will reset the 5-minute auto-lock timer. In other words, the device will automatically lock 5 minutes after the most recent parameter change.

● Password Change Procedure

To change the password, follow the procedure below.

Before performing a password change, ensure that the device is in the unlocked state — that is, read value of SET_PWD_KEY(0x0811) returns 0x0000. The password can only be changed in this state.

- ① Enable password change mode. Write 0x00AA to SET_PWD_KEY (0x0811) to activate the password change procedure.

CAN ID	DLC(data length)	Command Code	Data
0x00C0300	0x04	0x1108	0xAA00

- ② Enter the new password to ENTER_PWD (0x0810).
For example, to set a new password of 765432(string).

CAN ID	DLC(data length)	Command Code	Data
0x00C0300	0x04	0x1008	0x373635343332

- ③ Input the password again

CAN ID	DLC(data length)	Command Code	Data
0x00C0300	0x04	0x1008	0x373635343332

- ④ Verify password change result. Read SET_PWD_KEY (0x0811) to confirm whether the password has been successfully updated

CAN ID	DLC(data length)	Command Code
0x00C0300	0x2	0x1108

If the response returns 0x00FF, it indicates that the password change was successful.

CAN ID	DLC(data length)	Command Code	Data
0x00C0200	0x04	0x1108	0xFF00

6.1.5 CAN Bus Practical Operation

BIC Mode

The following steps will describe how to configure the BIC-5K-48 in communication mode and set the voltage/current parameters as follows: VOUT_SET : 60V, IOU_T_SET : 70A and IOU_T_SET_REV : -70A.

1. Set the address of the inverter to "0"

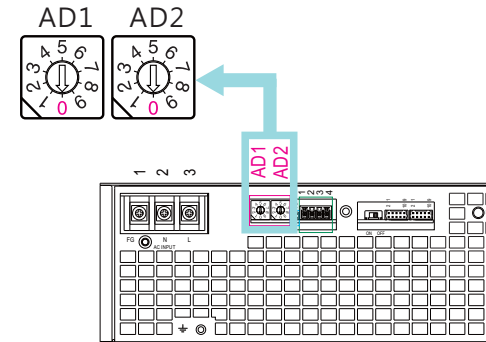

2. Connect the CANH/CANL pins of the master to the corresponding CANH(PIN2)/CANL(PIN3) pins of the COMM connector on the device. It is recommended to establish a common ground for the communication system to increase its communication reliability by using GND-AUX (PIN1) of COMM.

※ Set baud rate: 250kbps, type: extended

※ Adding a 120Ω termination resistor to both the controller and device's end can increase communication stability. If the unit is a terminal, it is recommended to connect a termination resistor, that is shorting circuit PIN1 and PIN 3 of CRL.

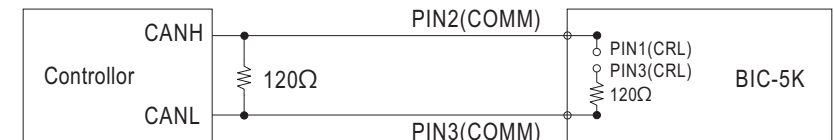

3. Configure communication settings after power on.

CAN ID	DLC(data length)	Command Code	Parameter
0xC0300	0x04	0xC200	0x0300

Command code : 0x00C2 (SYSTEM_CONFIG)

Data : 03(Lo) + 00(Hi). Please refer to definition of SYSTEM_CONFIG for detailed information

4. Set VOUT_SET to 60V

CAN ID	DLC(data length)	Command Code	Parameter
0xC0300	0x04	0x2000	0x7017

Command code : 0x0020(VOUT_SET) → 0x20 (Lo) + 0x 00(Hi)

Data : 60V → 6000 → 0x1770 → 0x70 (Lo) + 0x17 (Hi)

NOTE : Conversion factor for VOUT_SET is 0.01 · so $\frac{60V}{F=0.01} = 6000$ °

5. Set IOOUT_SET to 70A

CAN ID	DLC(data length)	Command Code	Parameter
0xC0300	0x04	0x3000	0x581B

Command code : 0x0030(IOOUT_SET) → 0x30 (Lo) + 0x 00(Hi)

Data : 70A → 7000 → 0x1B58 → 0x58 (Lo) + 0x1B (Hi)

NOTE : Conversion factor for IOOUT_SET is 0.01 · so $\frac{70V}{F=0.01} = 7000$ °

6. Set IOOUT_SET_REV to 70A

CAN ID	DLC(data length)	Command Code	Parameter
0xC0300	0x04	0x4201	0x581B

Command code : 0x0142(IOOUT_SET_REV) → 0x42 (Lo) + 0x 01(Hi)

Data : 70A → 7000 → 0x1B58 → 0x58 (Lo) + 0x1B (Hi)

NOTE : Conversion factor for IOOUT_SET_REV is 0.01 · so $\frac{70V}{F=0.01} = 7000$ °

7. Before connecting to the batteries or loads, it is recommended to review all of the settings and parameters using the appropriate commands. In the event that they do not meet your requirements, you may rewrite them as needed

EX: Read IOOUT_SET to check whether current level for AC to DC was set to a proper level.

Read IOOUT_SET

CAN ID	DLC(data length)	Command Code
0xC0300	0x04	0x3000

The unit returns data below :

CAN ID	DLC(data length)	Command Code	Parameter
0xC0300	0x04	0x3000	0x581B

Parameters : 0x58(Lo) + 0x1B(Hi) → 0x1B58 → 7000 → 7000x0.01(F) → 70A

8. Finally, short circuit Remote ON_OFF (PIN3) and +5V_AUX2 (PIN1) pins of the PAR1/ PAR2 connector on the device to remote on it to charge the batteries or provide energy to the loads.

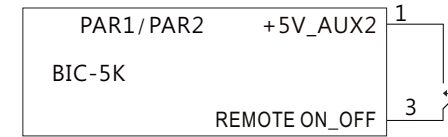

6.2 Modbus Protocol

The device supports Modbus RTU with the master-slave principle. Users are able to read and write parameters of the device through the protocol, including remote ON/OFF, AC voltage/frequency setting, etc. During data transfer, please follow the principle of first sending the Hi byte and then the Lo byte except Error Check (CRC16 checksum).

Control	Setting
Baud Rate	115200
Data Bits	8
Stop Bit	1
Parity	None
Flow Control	None

6.2.1 Communication Timing

- Min. request period (Controller to PSU/CHG): 50mSec °
- Max. response time (PSU/CHG to Controller): 12.5mSec °
- Min. packet margin time (Controller to PSU/CHG): 12.5mSec °

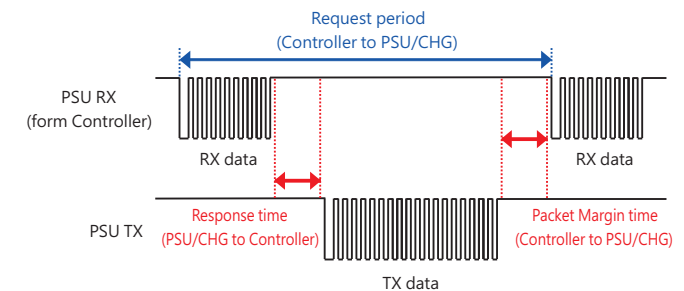

6.2.2 Modbus Frame Encapsulation

Modbus RTU consists of Additional Address, Function Code, Data and Error Check.

Additional Address	Function Code	Data	Error Check
1 byte	1 byte	N bytes	2 bytes

Additional address (1byte): Defines device's slave ID.

Function code (1byte): The function code is used to tell the slave what kind of action to perform.

Data (N bytes): For data exchange, contents and data length are dependent on different function codes.

Error Check (2bytes): Utilizes CRC-16.

6.2.3 Additional Address Definition

Additional address is the slave ID of the device. Each BIC-5K unit should have their unique and own device address to communicate over the Bus

Slave ID	Description
0xC0 + XX	XX means device address (assigned by AD1 and AD2). For example: Address is set at 63, meaning Slave ID = 0xC0 + 0x3F = 0xFF
0x00	Broadcast

Note : XX means the address of the BIC-5K. Please refer to 4.7 Communication Address/ID Assignment for detailed.

6.2.4 Function Code Description

The main purpose of the function codes is to tell the slave what kind of action to perform. For example: Function code 0x03 will query the slave to read holding registers and respond with the master their contents.

Function Code	
Read Holding Register	0x03
Read Input Register	0x04
Preset Single Register	0x06

6.2.5 Data Field and Command Lists

Data field provides additional information by the slave to complete the action specified by the function code (FC) in a request. The data field typically includes register addresses, count values, and written data. There are several forms according to the function codes.

FC = 0x03/0x04

Starting Address	Quantity of (Input) Registers
2 Bytes	2 Bytes

FC = 0x06

Register Address	Register Value
2 Bytes	2 Bytes

ORANGE : BIC Mode Dedicated Commands

BLUE : Grid-tied Mode Dedicated Commands

GREEN : Charger Mode Dedicated Commands

Command Code	Command Name	Function code	# of data Bytes	Description
0x0000	OPERATION	0x03,0x06	2	01:ON/00:OFF
0x0020	VOUT_SET*	0x03,0x06	2	Charge voltage setting (Factor =0.01)
0x0030	IOUT_SET*	0x03,0x06	2	Charge current setting (Factor =0.01)
0x0040	FAULT_STATUS	0x03	2	Summary status reporting
0x0050	READ_VIN	0x04	2	Single-phase input voltage (Bypass) (Factor =0.1)
0x0053	READ_IIN	0x04	2	Single-phase input current(Bypass) (Factor =0.1)
0x0056	READ_FREQ	0x04	2	Single-phase input frequency(Bypass) (Factor =0.01)
0x0060	READ_VOUT	0x04	2	DC voltage reading value (Factor =0.01)
0x0061	READ_IOUT	0x04	2	DC current reading value (Factor =0.01)
0x0062	READ_TEMPERATURE_1	0x04	2	Internal ambient temperature (Factor =0.1)
0x0070	READ_FAN_SPEED_1	0x04	2	Fan speed 1 reading value (Factor =1)
0x0071	READ_FAN_SPEED_2	0x04	2	Fan speed 2 reading value (Factor值 =1)
0x0080	MFR_ID_B0B5	0x03	6	Manufacturer's name
0x0083	MFR_ID_B6B11	0x03	6	Manufacturer's name
0x0086	MFR_MODEL_B0B5	0x03	6	Manufacturer's model name
0x0089	MFR_MODEL_B6B11	0x03	6	Manufacturer's model name

Command Code	Command Name	Function code	# of data Bytes	Description
0x008C	MFR_REVISION_B0B5	0x03	6	Firmware revision
0x008F	MFR_LOCATION_B0B2	0x03	4	Manufacturer's factory location
0x0091	MFR_DATE_B0B5	0x03	6	Manufacturer's date
0x0094	MFR_SERIAL_B0B5	0x03	6	Product serial number
0x0097	MFR_SERIAL_B6B11	0x03	6	Product serial number
0x00B0	CURVE_CC*	0x03, 0x06	2	Constant current setting of charge curve (Factor =0.01)
0x00B1	CURVE_CV*	0x03, 0x06	2	Constant voltage setting of charge curve (Factor =0.01)
0x00B2	CURVE_FV*	0x03, 0x06	2	Floating voltage setting of charge curve (Factor =0.01)
0x00B3	CURVE_TC*	0x03, 0x06	2	Taper current setting of charge curve (Factor =0.01)
0x00B4	CURVE_CONFIG	0x03, 0x06	2	Configuration setting of charging curve
0x00B5	CURVE_CC_TIMEOUT	0x03, 0x06	2	CC stage timeout setting value of charging curve (Factor =1)
0x00B6	CURVE_CV_TIMEOUT	0x03, 0x06	2	CV stage timeout setting value of charging curve (Factor =1)
0x00B7	CURVE_FV_TIMEOUT	0x03, 0x06	2	FV stage timeout setting value of charging curve (Factor =1)
0x00B8	CHG_STATUS	0x03	2	Charger's status reporting
0x00B9	BAT_ALM_VOLT*	0x03, 0x06	2	Battery low voltage alarm threshold (Factor =0.01)
0x00BA	BAT_SHDN_VOLT*	0x03, 0x06	2	Battery low voltage shutdown threshold (Factor =0.01)
0x00BB	BAT_RCHG_VOLT*	0x03, 0x06	2	Battery recharge voltage threshold (Factor =0.01)

Command Code	Command Name	Function code	# of data Bytes	Description
0x00BC	BAT_OV_ALM_VOLT	03h/06h	2	Battery high voltage alarm threshold (Factor=0.01)
0x00C0	SCALING_FACTOR	0x03	6	Scaling ratio
0x00C3	SYSTEM_STATUS	0x03	2	System status
0x00C4	SYSTEM_CONFIG	0x03, 0x06	2	System configuration
0x00CF	SETTING_UNLOCK	0x06	2	Setting unlock for user (NOTE1)
0x0100	INV_OPERATION	0x03, 0x06	2	Main mode configuration
0x011A	READ_VBAT	0x04	2	Battery voltage read value (Factor =0.01)
0x011B	READ_CHG_CURR	0x04	2	Battery current read value (Factor =0.01)
0x011C	BAT_CAPACITY	0x04	2	Battery capacity percent read value, 0~100%
0x011D	INV_STATUS	0x04	2	Inverter operation status reading
0x011F	READ_BP_WATT_HI	0x04	2	Bypass wattage read value (High) (Factor =0.1)
0x0120	READ_BP_WATT_LO	0x04	2	Bypass wattage read value (Low) (Factor =0.1)
0x0125	READ_BP_VA_HI	0x04	2	Bypass apparent power read value (High) (Factor =0.1)
0x0126	READ_BP_VA_LO	0x04	2	Bypass apparent power read value (Low) (Factor =0.1)
0x0140	DIR_CTRL	0x03, 0x06	1	A/D or D/A conversion control 00: A/D 01: D/A
0x0141	VOUT_SET_REV*	0x03, 0x06	2	Discharge voltage setting (Factor =0.01)
0x0142	IOUT_SET_REV*	0x03, 0x06	2	Discharge current setting (Factor =0.01)

Command Code	Command Name	Function code	# of data Bytes	Description
0x0143	BIDIR_CONFIG	0x03, 0x06	2	Bidirectional mode configuration
0x0150	POUT_USER_CMD*	0x03, 0x06	2	Power output control for user (Factor =0.1)
0x0202	AC_TYPE	0x03	2	AC type reading
0x0203	INV_STATE	0x03	2	Operation state reporting
0x0204	CONNECT_STATE	0x03	2	Grid connection state reporting
0x0205	GRID_ALARM	0x03	4	Grid mode alarm reporting
0x020B	W	0x04	2	Active power read value (Factor = 0.1)
0x020C	VA	0x04	2	Apprent power read value (Factor = 0.1)
0x020D	VAR	0x04	2	Reactive power read value (Factor = 0.1)
0x020E	PF	0x04	2	Power factor read value (Factor = 0.01)
0x020F	A	0x04	2	Total AC current read value (Factor = 0.01)
0x0210	LLV	0x04	2	Line to line voltage read value (Factor = 0.01)
0x0211	LNV	0x04	2	Line to nature voltage read value (Factor = 0.01)
0x0212	HZ	0x04	2	AC frequency read value (Factor = 0.01)
0x0268	THROT_SRC	0x03	4	Activated functions for grid control reporting
0x029D	W_MAX_RTG	0x03	2	Maximum active power output rating (Factor = 1)
0x029E	W_OVR_EXT_RTG	0x03	2	Rated active power under overexcitation (Factor = 1)

Command Code	Command Name	Function code	# of data Bytes	Description
0x029F	W_OVR_EXT_RTG_PF	0x03	2	Rated power factor under overexcitation (Factor = 0.01)
0x02A0	W_UND_EXT_RTG	0x03	2	Rated active power under underexcitation (Factor = 1)
0x02A1	W_UND_EXT_RTG_PF	0x03	2	Rated power factor under underexcitation (Factor = 0.01)
0x02A2	VA_MAX_RTG	0x03	2	Maximum apparent power output rating (Factor = 1)
0x02A3	VAR_MAX_INJ_RTG	0x03	2	Rated reactive power during injection (Factor = 1)
0x02A4	VAR_MAX_ABS_RTG	0x03	2	Rated reactive power during absorption (Factor = 1)
0x02A7	V_NOR_RTG	0x03	2	Normal AC voltage rating (Factor = 0.01)
0x02A8	V_MAX_RTG	0x03	2	Maximum AC voltage rating (Factor = 0.01)
0x02A9	V_MIN_RTG	0x03	2	Minimum AC voltage rating (Factor = 0.01)
0x02AA	A_MAX_RTG	0x03	2	Maximum AC current rating (Factor = 0.01)
0x02D1	GRID_TIE_REMOTE	0x03, 0x06	2	Remote on/off for grid mode
0x02D2	CONNECT_UPPER_VOLT	0x03, 0x06	2	Upper voltage threshold (format, *0.01%Un)
0x02D3	CONNECT_LOWER_VOLT	0x03, 0x06	2	Lower voltage threshold (format, *0.01%Un)
0x02D4	CONNECT_UPPER_FREQ	0x03, 0x06	2	Upper frequency threshold (format, *0.01Hz)
0x02D5	CONNECT_LOWER_FREQ	0x03, 0x06	2	Lower frequency threshold (format, *0.01Hz)
0x02D6	CONNECT_DLY_TIME	0x03, 0x06	2	Observation time (format, *0.01sec)
0x02D7	CONNECT_P_RATE	0x03, 0x06	2	The ramp-rate for connecton (format, *1%Pn/sec)

Command Code	Command Name	Function code	# of data Bytes	Description
0x02D8	RECONNECT_P_RATE	0x03, 0x06	2	The ramp-rate for reconnecton (format, *1%Pn/sec)
0x02E4	SAFTY_FUNC_CONFIG	0x03, 0x06	2	Safety function configuration
0x02E5	COUNTRY_SET	0x03, 0x06	2	Country/region configuration
0x02E8	CTRL_MODE	0x03, 0x06	2	Control mode
0x02E9	P_SET_RATE	0x03, 0x06	2	The ramp-rate for active power (format, *1%Pn/sec)
0x02EA	P_TAU	0x03, 0x06	2	The time constant for P(U) (format, *0.01sec)
0x02EB	Q_TAU	0x03, 0x06	2	The time constant For reactive power setting (format, *0.01sec)
0x02EC	P_SET	0x03, 0x06	2	Maximum active power output setting (format, *0.1%Pn)
0x02ED	Q_SET	0x03, 0x06	2	Maximum reactive power output setting (format, *0.1%Qn)
0x02EE	PF_SET	0x03, 0x06	2	cosφ set point (format, *0.01 PF)
0x02EF	PF_P_LOCKIN_V	0x03, 0x06	2	Lock in voltage for cosφ(P) mode (format, *0.01%Un)
0x02F0	PF_P_LOCKOUT_V	0x03, 0x06	2	Lock out voltage for cosφ(P) mode (format, *0.01%Un)
0x02F1	PF_P_CURVE_PF1	0x03, 0x06	2	F1 on the cosφ(P) Curve (format, *0.01 PF)
0x02F2	PF_P_CURVE_P1	0x03, 0x06	2	P1 on the cosφ(P) Curve (format, *0.1%Pn)
0x02F3	PF_P_CURVE_PF2	0x03, 0x06	2	Pf2 on the cosφ(P) Curve (format, *0.01 PF)
0x02F4	PF_P_CURVE_P2	0x03, 0x06	2	P2 on the cosφ(P) Curve (format, *0.1%Pn)
0x02F5	PF_P_CURVE_PF3	0x03, 0x06	2	Pf3 on the cosφ(P) Curve (format, *0.01 PF)

Command Code	Command Name	Function code	# of data Bytes	Description
0x02F6	PF_P_CURVE_P3	0x03, 0x06	2	P3 on the $\cos\phi(P)$ Curve (format, *0.1%Pn)
0x02F7	PF_P_CURVE_PF4	0x03, 0x06	2	Pf4 on the $\cos\phi(P)$ Curve (format, *0.01 PF)
0x02F8	PF_P_CURVE_P4	0x03, 0x06	2	P4 on the $\cos\phi(P)$ Curve (format, *0.1%Pn)
0x0327	Q_P_CURVE_Q1	0x03, 0x06	2	Q1 on the Q(P) Curve (format, *0.01%Qn)
0x0328	Q_P_CURVE_P1	0x03, 0x06	2	P1 on the Q(P) Curve (format, *0.1%Pn)
0x0329	Q_P_CURVE_Q2	0x03, 0x06	2	Q2 on the Q(P) Curve (format, *0.1%Qn)
0x032A	Q_P_CURVE_P2	0x03, 0x06	2	P2 on the Q(P) Curve (format, *0.1%Pn)
0x032B	Q_P_CURVE_Q3	0x03, 0x06	2	Q3 on the Q(P) Curve (format, *0.1%Qn)
0x032C	Q_P_CURVE_P3	0x03, 0x06	2	P3 on the Q(P) Curve (format, *0.1%Pn)
0x032D	Q_P_CURVE_Q4	0x03, 0x06	2	Q4 on the Q(P) Curve (format, *0.1%Qn)
0x032E	Q_P_CURVE_P4	0x03, 0x06	2	P4 on the Q(P) Curve (format, *0.1%Pn)
0x035D	Q_V_MIN_COS	0x03, 0x06	2	Minimum power factor limitation for Q(U) mode (format, *0.01 PF)
0x035E	Q_V_LOCKIN_P	0x03, 0x06	2	Lock in power for Q(U) mode (format, *0.1%Pn)
0x035F	Q_V_LOCKOUT_P	0x03, 0x06	2	Lock out power for Q(U) mode (format, *0.1%Pn)
0x0360	Q_V_CURVE_Q1	0x03, 0x06	2	Q1 on the Q(U) Curve (format, *0.1%Qn)
0x0361	Q_V_CURVE_V1	0x03, 0x06	2	V1 on the Q(U) Curve (format, *0.01%Un)
0x0362	Q_V_CURVE_Q2	0x03, 0x06	2	Q2 on the Q(U) Curve (format, *0.1%Qn)

Command Code	Command Name	Function code	# of data Bytes	Description
0x0363	Q_V_CURVE_V2	0x03, 0x06	2	V2 on the Q(U) Curve (format, *0.01%Un)
0x0364	Q_V_CURVE_Q3	0x03, 0x06	2	Q3 on the Q(U) Curve (format, *0.1%Qn)
0x0365	Q_V_CURVE_V3	0x03, 0x06	2	V3 on the Q(U) Curve (format, *0.01%Un)
0x0366	Q_V_CURVE_Q4	0x03, 0x06	2	Q4 on the Q(U) Curve (format, *0.1%Qn)
0x0367	Q_V_CURVE_V4	0x03, 0x06	2	V4 on the Q(U) Curve (format, *0.01%Un)
0x03A0	P_V_CURVE_P1	0x03, 0x06	2	P1 on the P(U) Curve (format, *0.1%Pn)
0x03A1	P_V_CURVE_V1	0x03, 0x06	2	V1 on the P(U) Curve (format, *0.01%Un)
0x03A2	P_V_CURVE_P2	0x03, 0x06	2	P2 on the P(U) Curve (format, *0.1%Pn)
0x03A3	P_V_CURVE_V2	0x03, 0x06	2	V2 on the P(U) Curve (format, *0.01%Un)
0x03A4	P_V_CURVE_P3	0x03, 0x06	2	P3 on the P(U) Curve (format, *0.1%Pn)
0x03A5	P_V_CURVE_V3	0x03, 0x06	2	V3 on the P(U) Curve (format, *0.01%Un)
0x03A6	P_V_CURVE_P4	0x03, 0x06	2	P4 on the P(U) Curve (format, *0.1%Pn)
0x03A7	P_V_CURVE_V4	0x03, 0x06	2	V4 on the P(U) Curve (format, *0.01%Un)
0x03D9	UVRT_VOLT1	0x03, 0x06	2	V1 on the UVRT Curve (format, *0.01%Un)
0x03DA	UVRT_TIME1	0x03, 0x06	2	T1 on the UVRT Curve (format, *0.01sec)
0x03DB	UVRT_VOLT2	0x03, 0x06	2	V2 on the UVRT Curve (format, *0.01%Un)
0x03DC	UVRT_TIME2	0x03, 0x06	2	T2 on the UVRT Curve (format, *0.01sec)

Command Code	Command Name	Function code	# of data Bytes	Description
0x03DD	UVRT_VOLT3	0x03, 0x06	2	V ₃ on the UVRT Curve (format, *0.01%Un)
0x03DE	UVRT_TIME3	0x03, 0x06	2	T ₃ on the UVRT Curve (format, *0.01sec)
0x03DF	UVRT_VOLT4	0x03, 0x06	2	V ₄ on the UVRT Curve (format, *0.01%Un)
0x03E0	UVRT_TIME4	0x03, 0x06	2	T ₄ on the UVRT Curve (format, *0.01sec)
0x03E1	UVRT_VOLT5	0x03, 0x06	2	V ₅ on the UVRT Curve (format, *0.01%Un)
0x03E2	UVRT_TIME5	0x03, 0x06	2	T ₅ on the UVRT Curve (format, *0.01sec)
0x03E3	UVRT_VOLT6	0x03, 0x06	2	V ₆ on the UVRT Curve (format, *0.01%Un)
0x03E4	UVRT_TIME6	0x03, 0x06	2	T ₆ on the UVRT Curve (format, *0.01sec)
0x03E5	UVRT_VOLT7	0x03, 0x06	2	V ₇ on the UVRT Curve (format, *0.01%Un)
0x03E6	UVRT_TIME7	0x03, 0x06	2	T ₇ on the UVRT Curve (format, *0.01sec)
0x0468	OVRT_VOLT1	0x03, 0x06	2	V ₁ on the OVRT Curve (format, *0.01%Un)
0x0469	OVRT_TIME1	0x03, 0x06	2	T ₁ on the OVRT Curve (format, *0.01sec)
0x046A	OVRT_VOLT2	0x03, 0x06	2	V ₂ on the OVRT Curve (format, *0.01%Un)
0x046B	OVRT_TIME2	0x03, 0x06	2	T ₂ on the OVRT Curve (format, *0.01sec)
0x046C	OVRT_VOLT3	0x03, 0x06	2	V ₃ on the OVRT Curve (format, *0.01%Un)
0x046D	OVRT_TIME3	0x03, 0x06	2	T ₃ on the OVRT Curve (format, *0.01sec)
0x046E	OVRT_VOLT4	0x03, 0x06	2	V ₄ on the OVRT Curve (format, *0.01%Un)

Command Code	Command Name	Function code	# of data Bytes	Description
0x046F	OVRT_TIME4	0x03, 0x06	2	T ₄ on the OVRT Curve (format, *0.01sec)
0x0470	OVRT_VOLT5	0x03, 0x06	2	V ₅ on the OVRT Curve (format, *0.01%Un)
0x0471	OVRT_TIME5	0x03, 0x06	2	T ₅ on the OVRT Curve (format, *0.01sec)
0x0472	OVRT_VOLT6	0x03, 0x06	2	V ₆ on the OVRT Curve (format, *0.01%Un)
0x0473	OVRT_TIME6	0x03, 0x06	2	T ₆ on the OVRT Curve (format, *0.01sec)
0x0474	OVRT_VOLT7	0x03, 0x06	2	V ₇ on the OVRT Curve (format, *0.01%Un)
0x0475	OVRT_TIME7	0x03, 0x06	2	T ₇ on the OVRT Curve (format, *0.01sec)
0x0609	LFSMO_FREQ_START	0x03, 0x06	2	Start frqncy of LFSM-O (format, *0.01Hz)
0x060A	LFSMO_FREQ_STOP	0x03, 0x06	2	Stop frqncy of LFSM-O (format, *0.01Hz)
0x060B	LFSMO_STOP_DLY	0x03, 0x06	2	Stop deay of LFSM-O (format, *0.01sec)
0x060C	LFSMO_DROOP_RATE	0x03, 0x06	2	Droop rate of LFSM-O (format, *0.1%)
0x060D	LFSMO_ACTIVE_DLY	0x03, 0x06	2	Activation delay of LFSM-O (format, *0.01%)
0x060E	LFSMU_FREQ_START	0x03, 0x06	2	Start frqncy of LFSM-U (format, *0.01Hz)
0x0611	LFSMU_DROOP_RATE	0x03, 0x06	2	Droop rate of LFSM-U (format, *0.1%)
0x0612	LFSMU_ACTIVE_DLY	0x03, 0x06	2	Activation delay of LFSM-U (format, *0.01sec)
0x0613	LFSM_P_REF	03h/06h	2	LFSM Pref setting (0 : Pn ; 1 : PM)
0x0640	UVP1_VOLT	0x03, 0x06	2	1st-level undervoltage protection (V) (format, *0.01%Un)

Command Code	Command Name	Function code	# of data Bytes	Description
0x0641	UVP1_TIME	0x03, 0x06	2	1st-level undervoltage trip time (T) (format, *0.01sec)
0x0642	UVP2_VOLT	0x03, 0x06	2	2nd-level undervoltage protection (V) (format, *0.01%Un)
0x0643	UVP2_TIME	0x03, 0x06	2	2nd-level undervoltage trip time (T) (format, *0.01sec)
0x0644	UVP3_VOLT	0x03, 0x06	2	3rd-level undervoltage protection (V) (format, *0.01%Un)
0x0645	UVP3_TIME	0x03, 0x06	2	3rd-level undervoltage trip time (T) (format, *0.01sec)
0x0646	OVP1_VOLT	0x03, 0x06	2	1st-level overvoltage protection (V) (format, *0.01%Un)
0x0647	OVP1_TIME	0x03, 0x06	2	1st-level overvoltage trip time (T) (format, *0.01sec)
0x0648	OVP2_VOLT	0x03, 0x06	2	2nd-level overvoltage protection (V) (format, *0.01%Un)
0x0649	OVP2_TIME	0x03, 0x06	2	2nd-level overvoltage trip time (T) (format, *0.01sec)
0x064A	OVP3_VOLT	0x03, 0x06	2	3rd-level overvoltage protection (V) (format, *0.01%Un)
0x064B	OVP3_TIME	0x03, 0x06	2	3rd-level overvoltage trip time (T) (format, *0.01sec)
0x064C	UFP1_FREQ	0x03, 0x06	2	1st-level underfrequency threshold (Hz) (format, *0.01%Un)
0x064D	UFP1_TIME	0x03, 0x06	2	1st-level underfrequency trip time (T) (format, *0.01sec)
0x064E	UFP1_TIME	0x03, 0x06	2	2nd-level underfrequency threshold (Hz) (format, *0.01%Un)
0x064F	UFP2_TIME	0x03, 0x06	2	2nd-level underfrequency trip time (T) (format, *0.01sec)
0x0650	UFP3_FREQ	0x03, 0x06	2	3rd-level underfrequency threshold (Hz) (format, *0.01%Un)
0x0651	UFP3_TIME	0x03, 0x06	2	3rd-level underfrequency trip time (T) (format, *0.01sec)

Command Code	Command Name	Function code	# of data Bytes	Description
0x0652	OFP1_FREQ	0x03, 0x06	2	1st-level overfrequency threshold (Hz) (format, *0.01%Un)
0x0653	OFP1_TIME	0x03, 0x06	2	1st-level overfrequency trip time (T) (format, *0.01sec)
0x0654	OFP2_FREQ	0x03, 0x06	2	2nd-level overfrequency threshold (Hz) (format, *0.01%Un)
0x0655	OFP2_TIME	0x03, 0x06	2	2nd-level overfrequency trip time (T) (format, *0.01sec)
0x0656	OFP3_FREQ	0x03, 0x06	2	3rd-level overfrequency threshold (Hz) (format, *0.01%Un)
0x0657	OFP3_TIME	0x03, 0x06	2	3rd-level overfrequency trip time (T) (format, *0.01sec)
0x0658	OVP10MIN_VOLT	0x03, 0x06	2	10-minute average overvoltage protection point (format, *0.01%Un)
0x0659	ROCOF_SLOPE	0x03, 0x06	2	Slope setting of ROCOF (format, *0.1Hz/sec)
0x065A	ROCOF_WINDOW_TIME	0x03, 0x06	2	Window time of ROCOF (format, *0.01sec)
0x0800	EVENTLOG_1	0x03	2	Most recent 1st event log record
0x0803	EVENTLOG_2	0x03	2	Most recent 2nd event log record
0x0806	EVENTLOG_3	0x03	2	Most recent 3rd event log record
0x0809	EVENTLOG_4	0x03	2	Most recent 4rd event log record
0x080C	EVENTLOG_5	0x03	2	Most recent 5th event log record
0x0820	ENTER_PWD_B0	0x06	2	Password_1 for DSO
0x0821	ENTER_PWD_B2	0x06	2	Password_2 for DSO
0x0822	ENTER_PWD_B4	0x06	2	Password_3 for DSO

Command Code	Command Name	Function code	# of data Bytes	Description
0x0823	SET_PWD_KEY	0x03, 0x06	2	Unlock/lock status reporting and password setting
0x0910	CLEAR_LOG	0x06	2	Clear recored logs

NOTE :

1. Before setting POUT_USER_CMD (0x0150), please utilize the SETTING_UBLOCK command to unlock. Refer to section 6.2.6.2 for detailed instructions.

2. Commands with * at the end support the EEP_OFF and EEP_CONFIG functions, which define the EEPROM write strategy. Please refer to SYSTEM_CONFIG (0x00C4) for detailed information.

Data conversion:

Actual Value = Communication Write/Read Value × Factor Value, where the factor value is used for both writing and reading during communication for data conversion. Each command may have a different factor value, which can be found in the command list or retrieved from the SCALING_FACTOR (0x00C0) command.

Example 1: If the communication read value for the READ_VOUT command is 0x0960 (hexadecimal), and the factor value for the command is 0.01: Actual Value = 0x0960 (hex) → 2400 (decimal) × 0.01 = 24V.

Example 2: The PF_SET (0x02EE) command supports both lagging and leading power factor values. The corresponding reactive power will be positive or negative accordingly. The conversion formula between PF_SET and PF is:
 $Q > 0$ (lagging) : $PF_SET = PF \times 100$
 $Q < 0$ (leading) : $PF_SET = -PF \times 100$
 If PF = 0.9, for example, then $PF_SET = 90 \rightarrow$ communication setting = 0x005A.

◎FAULT_STATUS(0x0040):

	Bit 7	Bit 6	Bit 5	Bit 4	Bit 3	Bit 2	Bit 1	Bit 0
High byte	---	---	---	---	---	---	UTP	HV_OVP
Low byte	HI_TEMP	OP_OFF	AC_FAIL	SHORT	OLP	OVP	OTP	FAN_FAIL

Low byte :

Bit 0 FAN_FAIL : Fan locked flag

0 = Fan working normally
 1 = Fan locked

Bit 1 OTP : Over temperature protection

0 = Internal temperature normal
 1 = Internal temperature too high

Bit 2 OVP : DC over voltage protection

0 = DC voltage normal
 1 = DC over voltage protected

Bit 3 OLP : DC over current protection

0 = DC current normal
 1 = DC over current protected

Bit 4 SHORT : Short circuit protection

0 = Shorted circuit do not exist
 1 = Shorted circuit protected

Bit 5 AC_FAIL : AC abnormal flag

0 = AC range normal
 1 = AC range abnormal

Bit6 OP_OFF : DC status

0 = DC turned on
 1 = DC turned off

Bit7 HI_TEMP : Internal high temperature alarm

0 = Internal temperature normal
 1 = Internal temperature high

High byte :

Bit 0 HV_OVP : HV over voltage protection

- 0 = HV voltage normal
- 1 = HV over voltage protected

Bit 1 UTP: Under temperature protection

- 0 = Internal temperature normal
- 1 = Internal temperature too low

©MFR_ID_B0B5(0x0080) is the first 6 codes of the manufacturer's name (ASCII);
MFR_ID_B6B11(0x0083) is the last 6 codes of the manufacturer's name (ASCII)
EX: manufacturer's name is MEANWELL→MFR_ID_B0B5 is MEANWE:
MFR_ID_B6B11 is LL

MFR_ID_B0B5					
Byte 0	Byte 1	Byte 2	Byte 3	Byte 4	Byte 5
0x4D	0x45	0x41	0x4E	0x57	0x45

MFR_ID_B6B11					
Byte 0	Byte 1	Byte 2	Byte 3	Byte 4	Byte 5
0x4C	0x4C	0x20	0x20	0x20	0x20

©MFR_MODEL_B0B5 (0x0086-0x0088)is the first 6 codes of the manufacturer's model name (ASCII); MFR_MODEL_B6B11 0x0089-0x008B) is the last 6 codes of the manufacturer's model ' name (ASCII)
EX: Model name is BIC-5K-24→ MFR_MODEL_B0B5 is BIC-5K;MFR_MODEL_B6B11 is 24

MFR_ID_B0B5					
Byte 0	Byte 1	Byte 2	Byte 3	Byte 4	Byte 5
0x53	0x48	0x50	0x2D	0x35	0x4B

MFR_ID_B6B11					
Byte 0	Byte 1	Byte 2	Byte 3	Byte 4	Byte 5
0x2D	0x32	0x34	0x20	0x20	0x20

©MFR_REVISION_B0B5(0x008C-0x008E)is the firmware revision (hexadecimal).
A range of 0x00(R00.0)~0xFE (R25.4) represents the firmware version of an MCU; 0xFF represents no MCU existed

EX: The supply has two MCUs, the firmware version of the MCU number 1 is version R25.4 (0xFE), the MCU number 2 is version R10.5 (0x69)

Byte 0	Byte 1	Byte 2	Byte 3	Byte 4	Byte 5
0xFE	0x69	0xFE	0xFF	0xFF	0xFF

©MFR_DATE_B0B5(0x0091-0x0093) is manufacture date (ASCII)
EX: MFR_DATE_B0B5 is 180101, meaning 2018/01/01

Byte 0	Byte 1	Byte 2	Byte 3	Byte 4	Byte 5
0x31	0x38	0x30	0x31	0x30	0x31

©MFR_SERIAL_B0B5(0x0094-0x0096) and MFR_SERIAL_B6B11(0x0097-0x0099) are defined as manufacture date and manufacture serial number (ASCII)
EX: The first unit manufactured on 2018/01/01→MFR_SERIAL_B0B5: 180101 ; MFR_SERIAL_B6B11: 000001

Byte 0	Byte 1	Byte 2	Byte 3	Byte 4	Byte 5
0x31	0x38	0x30	0x31	0x30	0x31

Byte 6	Byte 7	Byte 8	Byte 9	Byte 10	Byte 11
0x30	0x30	0x30	0x30	0x30	0x31

©CURVE_CONFIG(0x00B4) :

	Bit 7	Bit 6	Bit 5	Bit 4	Bit 3	Bit 2	Bit 1	Bit 0
High byte	---	---	---	---	---	FVTOE	CVTOE	CCTOE
Low byte	---	STGS	---	---	---	---	CUVS	

Low byte :

Bit 0:1 CUVS: Charge Curve Selection

- 00 = Customized Charge Curve (default)
- 01 = Gel Battery
- 10 = Flooded Battery
- 11 = LiFeO4 battery Battery

Bit 6 STGS : 2/3 Stage Charge Setting

- 0 = 3 stage charge (default, CURVE_VBST and CURVE_V FLOAT)
- 1 = 2 stage charge (only CURVE_VBST)

High byte :

Bit 0 CCTOE : Constant Current Stage Timeout Indication Enable
 0 = disabled (default)
 1 = enabled

Bit 1 CVTOE : Constant Voltage Stage Timeout Indication Enable
 0 = disabled (default)
 1 = enabled

Bit 2 FVTOE : Float Voltage Stage Timeout Indication Enable
 0 = disabled (default)
 1 = enabled

Note : Unsupported settings displays with "0"

©CHG_STATUS(0x00B8) :

	Bit 7	Bit 6	Bit 5	Bit 4	Bit 3	Bit 2	Bit 1	Bit 0
High byte	FVTOF	CVTOF	CCTOF	---	---	---	---	---
Low byte	---	---	---	---	FVM	CVM	CCM	FULLM

Low byte :

Bit 0 FULLM : Fully Charged Mode Status
 0 = NOT fully charged
 1 = fully charged

Bit 1 CCM : Constant Current Mode Status
 0 = the charger NOT in constant current mode
 1 = the charger in constant current mode

Bit 2 CVM : Constant Voltage Mode Status
 0 = the charger NOT in constant voltage mode
 1 = the charger in constant voltage mode

Bit 3 FVM : Float Mode Status
 0 = the charger NOT in float mode
 1 = the charger in float mode

High byte :

Bit 5 CCTOF : Time Out Flag of Constant Current Mode
 0 = NO time out in constant current mode
 1 = constant current mode timed out

Bit 6 CVTOF : Time Out Flag of Constant Voltage Mode
 0 = NO time out in constant voltage mode
 1 = constant voltage mode timed out

Bit 7 FVTOF : Time Out Flag of Float Voltage Mode
 0 = NO time out in float mode
 1 = float mode timed out

Note : Unsupported settings displays with "0"

©SCALING_FACTOR(0x00C0) :

Byte 5	Bit 7	Bit 6	Bit 5	Bit 4	Bit 3	Bit 2	Bit 1	Bit 0
Definition	Reserved				Reserved			
Supported?	NO				NO			
Byte 4	Bit 7	Bit 6	Bit 5	Bit 4	Bit 3	Bit 2	Bit 1	Bit 0
Definition	Reserved				Frequency Factor			
Supported?	NO				YES			
Byte 3	Bit 7	Bit 6	Bit 5	Bit 4	Bit 3	Bit 2	Bit 1	Bit 0
Definition	Watt Factor				IIN Factor / IAC Factor			
Supported?	YES				YES			
Byte 2	Bit 7	Bit 6	Bit 5	Bit 4	Bit 3	Bit 2	Bit 1	Bit 0
Definition	CURVE_TIMEOUT Factor				TEMPERATURE_1 Factor			
Supported?	YES				YES			
Byte 1	Bit 7	Bit 6	Bit 5	Bit 4	Bit 3	Bit 2	Bit 1	Bit 0
Definition	FAN_SPEED Factor				VIN Factor / VAC Factor			
Supported?	YES				YES			
Byte 0	Bit 7	Bit 6	Bit 5	Bit 4	Bit 3	Bit 2	Bit 1	Bit 0
Definition	IOUT Factor / IDC Factor				VOUT Factor / VDC Factor			
Supported?	YES				YES			

Bit 0 : 3 **VOUT Factor/VDC Factor** : The factor value for voltage-related commands

0x0=DC voltage relevant commands not supported

0x1~0x3=Not in use, reserved (default 0)

0x4=0.001

0x5=0.01

0x6=0.1

0x7=1.0

0x8=10

0x9=100

0xA~0xF=Reserved

Bit 4 : 7 **IOUT Factor/IDC Factor** : The factor value for DC current-related commands

0x0=DC voltage relevant commands not supported

0x1~0x3=Not in use, reserved (default 0)

0x4=0.001

0x5=0.01

0x6=0.1

0x7=1.0

0x8=10

0x9=100

0xA~0xF=Reserved

byte 1 :

Bit 0 : 3 **VIN Factor/VAC Factor** : The factor value of READ_VIN

0x0=AC voltage relevant commands not supported

0x1~0x3=Not in use, reserved (default 0)

0x4=0.001

0x5=0.01

0x6=0.1

0x7=1.0

0x8=10

0x9=100

0xA~0xF=Reserved

Bit 4 : 7 **FAN_SPEED Factor** : The factor value of READ_FAN_SPEED_1/2

0x0= Fan speed relevant commands not supported

0x1~0x3=Not in use, reserved (default 0)

0x4=0.001

0x5=0.01

0x6=0.1

0x7=1.0

0x8=10

0x9=100

0xA~0xF=Reserved

byte 2 :

Bit 0 : 3 **The factor value of READ_TEMPERATURE_1**

0x0=Internal temperature relevant commands not supported

0x1~0x3=Not in use, reserved (default 0)

0x4=0.001

0x5=0.01

0x6=0.1

0x7=1.0

0x8=10

0x9=100

0xA~0xF=Reserved

Bit 4 : 7 **CURVE_TIMEOUT Factor** : The Factor of CC/CV/Float timeout

0x0=CURVE_TIMEOUT relevant commands not supported

0x1~0x3=Not in use, reserved (default 0)

0x4=0.001

0x5=0.01

0x6=0.1

0x7=1.0

0x8=10

0x9=100

0xA~0xF=Reserved

byte 3 :

Bit 0 : 3 IIN Factor/IAC Factor : The Factor of input current/AC current

0x0=AC input current relevant commands not supported

0x1~0x3=Not in use, reserved (default 0)

0x4=0.001

0x5=0.01

0x6=0.1

0x7=1.0

0x8=10

0x9=100

0xA~0xF=Reserved

Bit 4 : 7 Watt Factor : The Factor of output AC wattage (Power/Reactive/VA)

0x0=AC wattage relevant commands not supported

0x1~0x3=Not in use, reserved (default 0)

0x4=0.001

0x5=0.01

0x6=0.1

0x7=1.0

0x8=10

0x9=100

0xA~0xF=Reserved

byte 4 :

Bit 0 : 3 Frequency Factor : The Factor of Frequency

0x0=Frequency relevant commands not supported

0x1~0x3=Not in use, reserved (default 0)

0x4=0.001

0x5=0.01

0x6=0.1

0x7=1.0

0x8=10

0x9=100

0xA~0xF=Reserved

◎SYSTEM_STATUS(0x00C3):

	Bit 7	Bit 6	Bit 5	Bit 4	Bit 3	Bit 2	Bit 1	Bit 0
High byte	---	---	---	---	---	---	---	---
Low byte	---	EEPER	INITIAL_STATE	---	---	DA_OK	DC_OK	M/S

Low byte :

Bit 0 M/S : Parallel mode status

0 = Current device is Slave

1 = Current device is Master

Bit 1 DC_OK : Secondary DD output voltage status

0 = Secondary DD output voltage status TOO LOW

1 = Secondary DD output voltage status NORMAL

Bit 2 DA_OK : Primary DA status

0 = Primary DA OFF or abnormal

1 = Primary DA ON normally

Bit 5 INITIAL_STATE : Device initialized status

0 = In initialization status

1 = NOT in initialization status

Bit 6 EEPER : EEPROM data access error

0 = EEPROM data access normal

1 = EEPROM data access error

Note : When an EEPROM data access error occurs, the device shuts down and then entering protection mode with the LED indicator off. It only can be recovered after the EEPROM error condition is resolved.

©SYSTEM_CONFIG(0x00C4) :

High byte	Bit 7	Bit 6	Bit 5	Bit 4	Bit 3	Bit 2	Bit1	Bit 0
Definition	---	---	---	---	---	EEP_OFF	EEP_CONFIG	
Low byte	Bit 7	Bit 6	Bit 5	Bit 4	Bit 3	Bit 2	Bit1	Bit 0
Definition	---	---	---	---	---	OPERATION_INIT		MOD_CTRL

Low byte :

Bit 0 MOD_CTRL : MODBus communication control status
 0 = The output voltage/current defined by control over SVR (default)
 1 = The output voltage, current, ON/OFF control defined by control over MODBus (VOUT_SET, IOUT_SET, OPERATION)

Bit 1 : 2 OPERATION_INIT : Pre-set value of power on operation command
 0b00 = Power OFF, pre-set 0x00(OFF)
 0b01 = Power ON, pre-set 0x01(ON) (default)
 0b10 = Pre-set is previous set value
 0b11 = not used, reserved

High byte :

Bit 0 : 1 Bit 0 : 1 EEP_CONFIG : EEPROM Configuration
 00 : Immediate. Changes to parameters are written to EEPROM immediately (default)
 01 : 1 minute delay. Write changes to EEPROM if all parameters remain unchanged for 1 minute
 10 : 10 minute delay. Write changes to EEPROM if all parameters remain unchanged for 10 minutes
 11 : Reserved

Bit 2 EEP_OFF : EEPROM storage function ON/OFF
 0 : Enable. Parameters to be saved into EEPROM (default)
 1 : Disable. Parameters NOT to be saved into EEPROM

©INN_OPERATION(0x0100) :

High byte	Bit 15	Bit 14	Bit 13	Bit 12	Bit 11	Bit 10	Bit 9	Bit 8
Definition	---	---	---	---	---	---	---	---
Low byte	Bit 7	Bit 6	Bit 5	Bit 4	Bit 3	Bit 2	Bit 1	Bit 0
Definition	---	---	---	CHG_FIRST	GRID_EN	CHG_EN	---	---

Low byte :

Bit 2 CHG_EN : Charger Mode enabling
 0 = Charger Mode disabled (default)
 1 = Charger Mode enabled

Bit 3 GRID_EN : Grid-tied Mode enabling
 0 = Grid-tied Mode disabled (default)
 1 = Grid-tied Mode enabled

Bit 4 CHG_FIRST : Charger first or not in Grid-tied + Charger Mode
 0 = Grid first (default)
 1 = Charging first

NOTE : BIC Mode is enabled when both CHG_EN and GRID_EN bits are logic 0.

©INV_STATUS(0x011D) :

	Bit 7	Bit 6	Bit 5	Bit 4	Bit 3	Bit 2	Bit1	Bit 0
High byte	---	---	---	---	---	---	---	---
Low byte	Bat_H_ALM	Bat_Low_ALM	---	---	CHG_ON	UTI_OK	---	---

Low byte:

Bit 2 UTI_OK : Utility Power Exist
 0 = Utility power failure
 1 = Utility Power normal

Bit 3 CHG_ON : Charger status
 0 = Charger OFF
 1 = Charger ON

Bit 6 Bat_Low_ALM : Battery low alarm
 0 = Battery low alarm is NOT triggered
 1 = Battery low alarm is triggered

Bit 7 BAT_H_ALM : Battery high alarm
 0 = Battery high alarm is NOT triggered
 1 = Battery high alarm is triggered

©BIDIR_CONFIG(0x0143):

High byte	Bit 7	Bit 6	Bit 5	Bit 4	Bit 3	Bit 2	Bit 1	Bit 0
Definition	---	---	---	---	---	---	---	---
Low byte	Bit 7	Bit 6	Bit 5	Bit 4	Bit 3	Bit 2	Bit 1	Bit 0
Definition	---	---	---	---	---	---	---	MODE

Low byte :

- Bit 0 MODE: Bidirectional mode configuration**
 0 = Bi-direction auto-detect mode. DIR_CTRL and C/D control (analog) UN-controllable (default)
 1 = Bi-direction battery mode. DIR_CTRL and C/D control (analog) controllable

©GRID_ALARM(0x0205):

Byte 1	Bit 7	Bit 6	Bit 5	Bit 4	Bit 3	Bit 2	Bit 1	Bit 0
Definition	---	---	---	---	---	---	---	---
Byte 1	Bit 7	Bit 6	Bit 5	Bit 4	Bit 3	Bit 2	Bit 1	Bit 0
Definition	---	---	---	---	---	---	---	---
Byte 1	Bit 7	Bit 6	Bit 5	Bit 4	Bit 3	Bit 2	Bit 1	Bit 0
Definition	---	COMM_ERR	EEPER	HW_ERR	FAN_LOCK	UTP	OTP	HV_OVP
Byte 0	Bit 7	Bit 6	Bit 5	Bit 4	Bit 3	Bit 2	Bit 1	Bit 0
Definition	BAT_UVP	BAT_OVP	---	ROCOF	GRID_UFP	GRID_OFP	GRID_UVP	GRID_OVP

Byte 0

- Bit 0 GRID_OVP : Overvoltage protection in grid-connected mode**
 0 = AC voltage normal
 1 = AC over-voltage protected
- Bit 1 GRID_UVP : Undervoltage protection in grid-connected mode**
 0 = AC voltage normal
 1 = AC under-voltage protected
- Bit 2 GRID_OFP : Overfrequency protection in grid-connected mode**
 0 = AC frequency normal
 1 = AC over-frequency protected

- Bit 3 GRID_UFP : Underfrequency protection in grid-connected mode**
 0 = AC frequency normal
 1 = AC under-frequency protected

- Bit 4 ROCOF : ROCOF protection in grid-connected mode**
 0 = ROCOF normal
 1 = ROCOF abnormal protected

- Bit 6 BAT_OVP : Battery overvoltage protection**
 0 = battery voltage normal
 1 = Battery overvoltage protected

- Bit 7 BAT_UVP : Battery undervoltage protection**
 0 = battery voltage normal
 1 = Battery undervoltage protected

Byte 1

- Bit 0 HV_OVP : HV over voltage protection**
 0 = HV voltage normal
 1 = HV over voltage protected

- Bit 1 OTP : Over temperature protection**
 0 = Internal temperature normal
 1 = Internal temperature too high

- Bit 2 UTP : Under temperature protection**
 0 = Internal temperature normal
 1 = Internal temperature too low

- Bit 3 FAN_LOCK : Fan locked flag**
 0 = Fan working normally
 1 = Fan locked

Bit 4 HW_ERROR : Hardware error
 0 = hardware normal
 1 = hardware abnormal protected

Bit 5 EEPER : EEPROM data access error
 0 = EEPROM data access normal
 1 = EEPROM data access error

Bit 6 COMM_ERR : Internal communication access error
 0 = Internal communication access normal
 1 = Internal communication access error

©THROT_SRC(0x0268) :

Byte 3	Bit 7	Bit 6	Bit 5	Bit 4	Bit 3	Bit 2	Bit 1	Bit 0
Definition	---	---	---	---	---	---	---	---
Byte 1	Bit 7	Bit 6	Bit 5	Bit 4	Bit 3	Bit 2	Bit 1	Bit 0
Definition	---	---	---	---	---	---	---	---
Byte 1	Bit 7	Bit 6	Bit 5	Bit 4	Bit 3	Bit 2	Bit 1	Bit 0
Definition	---	PF_P	PF_SET	Q_P	Q_U	Q_SET	P_U	P_SET
Byte 0	Bit 7	Bit 6	Bit 5	Bit 4	Bit 3	Bit 2	Bit 1	Bit 0
Definition	---	DERATED	LFSMU	LFSMO	---	---	UVRT	OVRT

Byte 0
Bit 0 UVRT : UVRT enabling
 0 = disabled
 1 = enabled

Bit 1 UVRT: UVRT
 0 = the output control is not limited by UVRT
 1 = the output control is limited by UVRT

Bit 4 LFSMO: LFSM-O
 0 = the output control is not limited by LFSM-O
 1 = the output control is limited by LFSM-O

Bit 5 LFSMU: LFSM-U
 0 = the output control is not limited by LFSM-U
 1 = the output control is limited by LFSM-U

Bit 6 DERATED: DERATED
 0 = the output control is not limited by DERATED
 1 = the output control is limited by DERATED

Byte 1

Bit 0 P_SET: Maximum active power output setting
 0 = the output control is not limited by P_SET
 1 = the output control is limited by P_SET

Bit 1 P_U: P(U) Curve
 0 = the output control is not limited by P(U)
 1 = the output control is limited by P(U)

Bit 2 Q_SET: Maximum reactive
 0 = the output control is not limited by Q_SET
 1 = the output control is limited by Q_SET

Bit 3 Q_U: Q(U) curve
 0 = the output control is not limited by Q(U)
 1 = the output control is limited by Q(U)

Bit 4 Q_P: Q(P) curve
 0 = the output control is not limited by Q(P)
 1 = the output control is limited by Q(P)

Bit 5 PF_SET: cosφ set point
 0 = the output control is not limited by PF_SET
 1 = the output control is limited by PF_SET

Bit 6 PF_P: cosφ(P) curve
 0 = the output control is not limited by PF_P
 1 = the output control is limited by PF_P

©SAFTY_FUNC_CONFIG(0x02E4) :

High byte	Bit 7	Bit 6	Bit 5	Bit 4	Bit 3	Bit 2	Bit 1	Bit 0
Definition	---	---	---	---	---	---	ANTI_ISL	NS_PROTECT
Low byte	Bit 7	Bit 6	Bit 5	Bit 4	Bit 3	Bit 2	Bit 1	Bit 0
Definition	---	ROCOF	LFSMU	LFSMO	---	---	OVRT	UVRT

Low byte :

Bit 0 UVRT : UVRT enabling

0 = disabled

1 = enabled

Bit 1 OVRT : OVRT enabling

0 = disabled

1 = enabled

Bit 4 LFSMO : LFSM-O enabling

0 = disabled

1 = enabled

Bit 5 LFSMU : LFSM-U enabling

0 = disabled

1 = enabled

Bit 6 RPCPF : ROCOF protection enabling

0 = disabled

1 = enabled

High byte :

Bit 0 NS_PROTECT : NS protection enabling

0 = disabled

1 = enabled

Bit 1 ANTI_ISL : Active anti-islanding enabling (SFS)

0 = disabled

1 = enabled

©CTRL_MODE(0x02E8) :

High byte	Bit 7	Bit 6	Bit 5	Bit 4	Bit 3	Bit 2	Bit 1	Bit 0
Definition	---	---	---	---	---	---	---	CTRL_STORAGE_CFG
Low byte	Bit 7	Bit 6	Bit 5	Bit 4	Bit 3	Bit 2	Bit 1	Bit 0
Definition	Q_CTRL_MODE				---	---	---	PU_EN

Low byte :

Bit 0 PU_EN : P(U) enabling

0 = disabled (default)

1 = enabled

Bit 4-7 Q_CTRL_MODE : Reactive power control mode setting

0000 = reactive power control mode dialbed

0001 = Q setpint mode

0010 = Q(U) mode

0011 = Q(P) mode

0100 = Cos ϕ setpint (default)

0101 = Cos ϕ (P) mode

High byte :

**Bit 0 CTRL_STORAGE_CFG : EEPROM stogarge configriaton for
GRID_TIE_REMOTE / P_SET / Q_SET / PF_SET**

0 = Do not store command parameters (default)

1 = Store command parameters

(GRID_TIE_REMOTE / P_SET / Q_SET / PF_SET) into the EEPROM

6.2.6 Modbus Communication Examples

The following provides examples of request and response for each function code of the Modbus RTU.

6.2.6.1 Function code

6.2.6.1.1 Read Holding Registers (FC = 0x03)

The request message specifies the starting register and quantity of registers to be read. For example: the master requests the content of analog output holding registers 0x008C-0 008E (MFR_REVISION_B0B5) from slave 0

Request:

0xC0	0x03	0x008C	0x0003	0xD4F1
------	------	--------	--------	--------

0xC0: Slave ID 0

0x03: Function code 3 (Read Analog Output Holding R Registers)

0x008C: The Data Address of the first register requested

0x0003: The total number of registers requested (Read 3 registers from 0x008C to 0x008E)

0xD4F1: CRC16 Error Check. Please be aware that CRC sending the Lo byte first

Response:

0xC0	0x03	0x06	0x0A0A0AFFFFFF	0xD613
------	------	------	----------------	--------

0xC0: Slave ID 0

0x03: Function code 3 (Read Analog Output Holding R Registers)

0x06: The number of data bytes to follow (6 bytes).

0x0A0A0AFFFFFF, meaning that the firmware version of the MCU number 1~number 3 is R01.0

0xAD38: CRC16 Error Check. Please be aware that CRC sending the Lo byte first.

6.2.6.1.2 Read Input Register (FC=0x04)

The request message specifies the starting register and quantity of registers to be read. For example: The master requests the content of analog input register 0x0056 (READ_FREQ) from slave 0.

Request:

0xC0	0x04	0x0056	0x0001	0xC10B
------	------	--------	--------	--------

0xC0: Slave ID 0

0x04: Function code 4 (Read Analog Input Register)

0x0056: The Data Address of the first register requested

0x0001: The total number of registers requested (read only 1 registers from 0x0056)

0xC10B: CRC16 Error Check. Please be aware that CRC sending the Lo byte first.

Response:

0xC0	0x04	02	0x1770	0x8AF5
------	------	----	--------	--------

0xC0: Slave ID 0

0x04: Function code 4 (Read Analog Input Register)

0x02: The number of data bytes to follow (2 bytes)

0x1770: The contents of register : 0x0056 (READ_FREQ). 0x 1770 = 6000 = 60.00Hz

0x8AF5: CRC16 Error Check. Please be aware that CRC sending the Lo byte first.

6.2.6.1.3 Write Single Register (FC=0x06)

The request message specifies the register reference to be written.

For example: The master writes 40V to analog output holding register of 0x00B9 (BAT_ALM_VOLT) for slave 0 .

Request:

0xC0	0x06	0x00B9	0x0FA0	0x4D76
------	------	--------	--------	--------

0xC0: Slave ID 0

0x06: Function code 6 (Preset Single Register)

0x00B9: The Data Address of the register

0x0FA0: The value to write. 0x0FA0 → 4000 = 40V

0x4D76: CRC16 Error Check. Please be aware that CRC sending the Lo byte first

Response:

The normal response is an echo of the query, returned after the register contents have been written.

6.2.6.2 POUT_USER_CMD(0x0150) Settings for User

To avoid improper output power configurations in Grid-tied Mode, the POUT_USER_CMD (0x0150) register requires a different setup process. It must be unlocked via the SETTING_UNLOCK (0x00CF) command prior to modification.

C0 06 00 CF 4D 57 DD 8A	Unlock password is 0x4D57(MW)
C0 06 01 50 88 13 BF 3B	Set POUT_USER_CMD

6.2.6.3 Event Logs

6.2.6.3.1 Read Event Logs

The event log commands (0x0800 – 0x080C) record significant events that occurred in the device. The errors information is divided into three categories : grid-related, DC-related, and others, and is intended to support troubleshooting and fault analysis.

Type	Event	Data (Decimal)	Data (Hexadecimal)
GRID	GRID_OVP (Grid Over-Voltage Protection)	1001	0x03E9
	GRID_UVP (Grid Under-Voltage Protection)	1002	0x03EA
	GRID_OFP (Grid Over-Frequency Protection)	1003	0x03EB
	GRID_UFP (Grid Under-Frequency Protection)	1004	0x03EC
	GRID_ROCOF (Grid Rate-Of-Change-Of-Frequency Protection)	1009	0x03F1
	GRID_DISC (Grid Disconnection)	1011	0x03F3
DC	VBUS_OVP (Internal DC bus Over-Voltage Protection)	3001	0x0BB9
	VBUS_UVP (Internal DC bus Under-Voltage Protection)	3002	0x0BBA
	DC_OVP (DC end Over-Voltage Protection)	3003	0x0BBB
	DC_UVP (DC end Under-Voltage Protection)	3004	0x0BBC
	DC_OLP (DC end Over-Load Protection)	3005	0x0BBD
	DC_SCP (DC end Short-Circuit Protection)	3006	0x0BBE
	CHG_OTE (Charge time out)	3008	0x0BC0
	DD FAIL (Internal protection triggered at the secondary end)	3012	0x0BC4
	OTP (Over-Temperature Protection)	4001	0x0FA1
DC	UTP (Under-Temperature Protection)	4002	0x0FA2
	FANLOCK	4004	0x0FA4
	HW_ERROR (Internal hardware error)	4005	0x0FA5

Type	Event	Data (Decimal)	Data (Hexadecimal)
OTHER	COMM_ERROR (Internal communication error)	4006	0x0FA6
	EEP_ERROR (EEPROM access error)	4007	0x0FA7
	RELAY_ERROR	4008	0x0FA8

NOTE : 1.This device can store up to five event records. The most recent event is recorded in EVENTLOG_1 (0x0800), and the remaining events are shifted accordingly from EVENTLOG_2 (0x0803) to EVENTLOG_5 (0x080C). When more than five events are recorded, the oldest record is removed. For example :

	T1	T2	T3	T4	T5	T6 (latest)
Event	GRID_OVP	GRID_OFP	GRID_DISC	OTP	DC_UVP	FANLOCK
EVENTLOG_1 (0x0800)	1001	1003	1011	4001	3004	4004
EVENTLOG_2 (0x0803)	0	1001	1003	1011	4001	3004
EVENTLOG_3 (0x0806)	0	0	1001	1003	1011	4001
EVENTLOG_4 (0x0809)	0	0	0	1001	1003	1011
EVENTLOG_5 (0x080C)	0	0	0	0	1001	1003
Description	GRID_OVP is stored in EVENTLOG_1.	GRID_OFP is stored in EVENTLOG_1. GRID_OVP shifted to EVENTLOG_2	GRID_DISC is stored in EVENTLOG_1. GRID_OVP shifted to EVENTLOG_3	OTP is stored in EVENTLOG_1. GRID_OVP shifted to EVENTLOG_4	DC_UVP is stored in EVENTLOG_1. GRID_OVP shifted to EVENTLOG_5.	FANLOCK is stored in EVENTLOG_1. GRID_OVP is removed from the EEPROM.

2.Event log data is stored in the EEPROM and is retained after power-off. To clear the event logs, please refer to Section 6.2.6.3.2 Clear Event Log.

6.2.6.3.2 Clear Event Logs

Event log clearing is supported through the CLEAR_LOG (0x0910) command. The steps for removing the stored logs are provided below:

C0 06 09 10 00 AA 1B 3D	Clear even logs
-------------------------	-----------------

6.2.6.4 Password Setting for the Grid Connection Parameters for DSO

According to the EN 50549 standard, grid-connection parameters are accessible only to the DSO and must be managed under an authorization control mechanism. Registers ranging from 0x0202 (AC_TYPE) to 0x065A (ROCOF_WINDOW_TIME) can only be configured after the device is unlocked.

The default password is "000000" (string) or the unlocked state. When the password remains at its default value, all grid-connection parameters can be modified freely without entering the password. The current lock status can be read from SET_PWD_KEY (0x0823)

Read value from SET_PWD_KEY(0x0823)	Status
0x0000	Unlocked or no password
0x00FE	Locked or incorrect password
0x0055	Non-default password. A password for unlock is required

● Password Unlock Procedure

The following example illustrates how to unlock the device when the password is set to 765432 (string).

- ① Enter the password to ENTER_PWD_B0 (0x0820)

C0	06	08 20	37 36	0C 97
----	----	-------	-------	-------

- ② Enter the password to ENTER_PWD_B2 (0x0821)

C0	06	08 21	35 34	DD F6
----	----	-------	-------	-------

- ③ Enter the password to ENTER_PWD_B4 (0x0822)

C0	06	08 22	33 32	AE 54
----	----	-------	-------	-------

- ④ Read the SET_PWD_KEY (0x0823) status

C0	03	08 23	00 01	67 71
----	----	-------	-------	-------

If the response returns 0x0000, it indicates that the password has been successfully entered, and the grid connection parameters can now be modified

C0	03	00 01	00 00	04 DB
----	----	-------	-------	-------

- ⑤ Lock the device manually (or wait 5 minutes for automatic locking)

C0	06	08 23	00 55	AA 8E
----	----	-------	-------	-------

NOTE : When the BIC-5K is in the unlocked state, receiving any new grid-connection parameter change will reset the 5-minute auto-lock timer. In other words, the device will automatically lock 5 minutes after the most recent parameter change.

● Password Change Procedure

To change the password, follow the procedure below. Before performing a password change, ensure that the device is in the unlocked state — that is, SET_PWD_KEY (0x0823) returns a value of 0x0000. The password can only be changed in this state.

- ① Enable password change mode. Write 0x00AA to SET_PWD_KEY (0x0823) to activate the password change procedure.

C0	06	08 23	00 AA	EACE
----	----	-------	-------	------

- ② During this procedure, sequentially enter the new password into the following registers, ENTER_PWD_B0 (0x0820), ENTER_PWD_B2 (0x0821) and ENTER_PWD_B4 (0x0822). For example the new password is 765432(string).

C0	06	08 20	37 36	0C 97
----	----	-------	-------	-------

C0	06	08 21	35 34	DD F6
----	----	-------	-------	-------

C0	06	08 22	33 32	AE 54
----	----	-------	-------	-------

- ③ Input the password again

C0	06	08 20	37 36	0C 97
----	----	-------	-------	-------

C0	06	08 21	35 34	DD F6
----	----	-------	-------	-------

C0	06	08 22	33 32	AE 54
----	----	-------	-------	-------

- ④ Verify password change result. Read SET_PWD_KEY (0x0823) to confirm whether the password has been successfully updated

C0	03	08 23	00 01	67 71
----	----	-------	-------	-------

If the response returns 0x00FF, it indicates that the password change was successful.

C0	03	0001	00 FF	44 9B
----	----	------	-------	-------

6.2.7 Modbus Practical Operation

The following steps will describe how to configure the BIC-5K-48 in communication mode and set the voltage/current parameters as follows: VOUT_SET: 60 V, IOU_SET: 70 A and IOU_SET_REV: -70 A

1. Set the address of the inverter to "0"

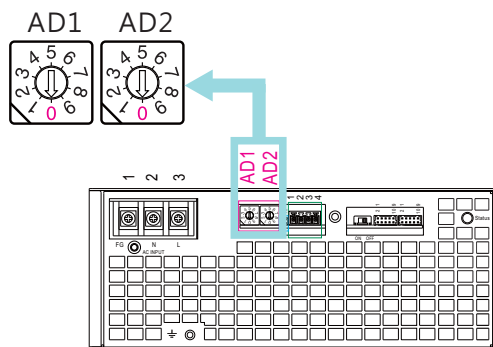

2. Connect the D+/D- pins of the master to the corresponding D+ (PIN2) and D-(PIN3) pins of the COMM connector on the device. It is recommended to establish a common ground for the communication system to increase its communication reliability by using GND-AUX (PIN1) of COMM.

If the unit is a terminal, it is recommended to connect a termination resistor, that is shorting circuit PIN1 and PIN 3 of CRL.

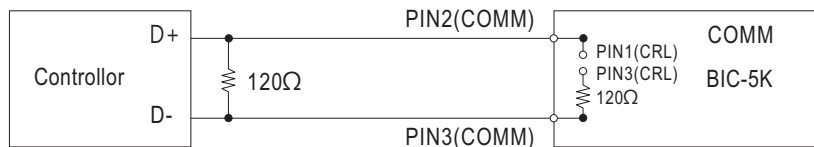

3. Configure communication settings after power on

0xC0	0x06	0x00C4	0x0003	0x9817
------	------	--------	--------	--------

0xC0 : Slave ID0
 0x06 : Function code 6 (Write Single Register)
 0x00C2 : SYSTEM_CONFIG register
 0x0003 : Set to communication mode. Please refer to definition of SYSTEM_CONFIG for detailed information
 0x78E6 : CRC16Error Check

4. Set VOUT_SET to 60V

0xC0	0x06	0x0020	0x1770	0x2B47
------	------	--------	--------	--------

0xC0 : Slave ID0
 0x06 : Function code 6(Write Single Register)
 0x0020 : VOUT_SETregister
 0x1770 : 60V → 6000 → 0x1770
 0x2B47 : CRC16 Error Check

NOTE : Conversion factor for VOUT_SET is 0.01 · so $\frac{60V}{F=0.01} = 6000 \cdot$

5. Set IOU_SET to 70A

0xC0	0x06	0x0030	0x1B58	0x921E
------	------	--------	--------	--------

0xC0 : Slave ID0
 0x06 : Function code 6(Write Single)Register
 0x0030 : IOU_SETregister
 0x1B58 : 70A → 7000 → 0x1B58
 0x921E : CRC16 Error Check

NOTE : Conversion factor for IOU_SET is 0.01 · so $\frac{70V}{F=0.01} = 7000$

6. Set IOU_SET_REV to 70A

0xC0	0x06	0x0142	0x1B58	0x33F9
------	------	--------	--------	--------

0xC0 : Slave ID0
 0x06 : Function code 6(Write Single)
 0x0142 : IOU_SET_REVregister
 0x1B58 : 70A 7000 0x1B58
 0x33F9 : CRC16 Error Check

NOTE : Conversion factor for OUT_SET_REC is 0.01 · so $\frac{70V}{F=0.01} = 7000$

7. Before connecting to the batteries or loads, it is recommended to review all of the settings and parameters using the appropriate commands. In the event that they do not meet your requirements, you may rewrite them as needed

EX: Read IOOUT_SET to check whether current level for AC to DC was set to a proper level.

Read IOOUT_SET

0xC0	0x03	0x0030	0x0001	0x94D4
------	------	--------	--------	--------

The unit returns data below

0xC0	0x03	0x0001	0x1B58	0x0FD1
------	------	--------	--------	--------

Parameters : 0x1B58 → 7000 → 7000x0.01(F) → 70A

8. Finally, short circuit Remote ON_OFF (PIN3) and +5V_AUX2 (PIN1) pins of the PAR1/ PAR2 connector on the device to remote on it to charge the batteries or provide energy to the loads

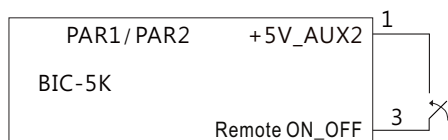

6.3 Value Range and Tolerance

(1) Display parameters

CAN bus/ Modbus Command		Model	Display value range	Tolerance
0x0050	READ_VIN	ALL	0~305Vac	±2.3Vac
0x0053	READ_IIN	ALL	0~25A	±1.0A
0x0056	READ_FREQ	ALL	0~70Hz	±0.05Hz
0x0060	READ_VOUT	24	0~35V	±0.24V
		48	0~70V	±0.48V
		96	0~120V	±0.96V
		380	0~450V	±3.8V
0x0061	READ_IOUT	24	-280~250A	±2.1A
		48	-138~125A	±1.1A
		96	-70~65A	±0.6A
		380	-20~18A	±0.15A
0x0062	READ_TEMPERATURE_1	ALL	-40~110°C	±5 °C
0x0070	READ_FAN_SPEED_1	ALL	0~13000RPM	±1000RPM
0x0071	READ_FAN_SPEED_2	ALL	0~13000RPM	±1000RPM
0x00C0	SCALING_FACTOR	ALL	0x000576767655	---
0x011A	READ_VBAT	24	0~35V	±0.24V
		48	0~70V	±0.48V
		96	0~120V	±0.96V
		380	0~450V	±3.8V
0x011B	READ_CHG_CURR Note i	24	-280~250A	±2.1A
		48	-138~125A	±1.1A
		96	-70~65A	±0.6A
		380	-20~18A	±0.15A
0x011C	BAT_CAPACITY	ALL	25/50/75/100%	±25%
0x011F	READ_BP_WATT_HI	ALL	-10000~	±100W
0x0120	READ_BP_WATT_LO		10000W	

CAN bus/ Modbus Command		Model	Display value range	Tolerance
0x0125	READ_BP_VA_HI	ALL	0~10000VA	±100VA
0x0126	READ_BP_VA_LO			
0x0202	AC_TYPE	ALL	0: Single-phase	---
0x0203	INV_STATE	ALL	0: Standby 1: BIC 2: Charge 3: Grid-tie 4: Shutdown 5: Fault	---
0x0204	CONNECT_STATE	ALL	0: Disconnected 1: Connected	---
0x020B	W	ALL	0~10000W	±100W
0x020C	VA	ALL	0~10000VA	±100VA
0x020D	VAR	ALL	0~3000VAR	±100VAR
0x020E	PF	ALL	-1~+1	±0.01
0x020F	A	ALL	0~25A	±0.3A
0x0210	LLV	ALL	0~305Vac	±2.3Vac
0x0211	LNV	ALL	0~305Vac	±2.3Vac
0x0212	HZ	ALL	0~70Hz	±0.05Hz
0x029D	W_MAX_RTG	ALL	5000W	---
0x029E	W_OVR_EXT_RTG	ALL	4500W	---
0x029F	W_OVR_EXT_RTG_PF	ALL	0.9	---
0x02A0	W_UND_EXT_RTG	ALL	4500W	---
0x02A1	W_UND_EXT_RTG_PF	ALL	0.9	---
0x02A2	VA_MAX_RTG	ALL	5000VA	---
0x02A3	VAR_MAX_INJ_RTG	ALL	2180VAR	---
0x02A4	VAR_MAX_ABS_RTG	ALL	2180VAR	---
0x02A7	V_NOR_RTG	ALL	230Vac	---
0x02A8	V_MAX_RTG	ALL	253Vac	---
0x02A9	V_MIN_RTG	ALL	195.5Vac	---
0x02AA	A_MAX_RTG	ALL	25.6A	---

(2)Control parameters

ORANGE : BIC Mode Dedicated Commands

BLUE : Grid-tied Mode Dedicated Commands

GREEN : Charger Mode Dedicated Commands

CAN bus/ Modbus Command		Model	Display value range	Tolerance	Default
0x0000	OPERATION	ALL	00h(OFF)/01h(ON)	N/A	01h(ON)
0x0020	VOUT_SET	24V	19~33A	±0.24A	24V(CV Mode) 25.2V(Battery Mode)
		48V	38~66A	±0.48A	48V(CV Mode) 50.4V(Battery Mode)
		96V	76~112A	±0.96A	96V(CV Mode) 96V(Battery Mode)
		380V	280~430A	±3.8A	380V(CV Mode) 400V(Battery Mode)
0x0030	IOUT_SET	24V	+4.16 ~ +228.8A	±2.1A	228.8A
		48V	+2.08 ~ +114.4A	±1.1A	114.4A
		96V	+1.04 ~ +57.2A	±0.6A	57.2A
		380V	+0.3 ~ +16.5A	±0.15A	16.5A
0x00B0	CURVE_CC	24V	34.2~171A	±2.1A	171A
		48V	17.1~85.5A	±1.1A	85.5A
		96V	8.9~44.5A	±0.6A	44.5A
		380V	2.5~12.5A	±0.15A	12.5A
0x00B1	CURVE_CV	24V	20~33A	±0.24A	28.8V
		48V	40~66A	±0.48A	57.6V
		96V	80~112A	±0.96A	112V
		380V	290~430A	±3.8A	400V
0x00B2	CURVE_FV	24V	20V~CURVE_CV	±0.24A	27.6V
		48V	40V~CURVE_CV	±0.48A	55.2V
		96V	80V~CURVE_CV	±0.96A	108.8V
		380V	290~CURVE_CV	±3.8A	385V

CAN bus/ Modbus Command		Model	Display value range	Tolerance	Default
0x00B3	CURVE_TC	24V	3.42~51.3A	±2.1A	17.1A
		48V	1.71~25.65A	±1.1A	8.55A
		96V	0.89~13.35A	±0.6A	4.45A
		380V	0.25~3.75A	±0.15A	1.25A
0x00B4	CURVE_CONFIG	ALL	N/A	N/A	0400h
0x00B5	CURVE_CC_TIMEOUT	ALL	1 ~ 64800 minute	30sec~5 min	600 minute
0x00B6	CURVE_CV_TIMEOUT				
0x00B7	CURVE_FV_TIMEOUT				10 minute
0x00B9	BAT_ALM_VOLT	24V	18.8V~25V	±0.24V	22V
		48V	37.6V~50V	±0.48V	44V
		96V	75.2V~100V	±0.96V	88V
		380V	275V~335V	±3.8V	300V
0x00BA	BAT_SHDN_VOLT	24V	18.4V~24V	±0.24V	19V
		48V	36.8V~48V	±0.48V	38V
		96V	73.6V~96V	±0.96V	76V
		380V	270V~320V	±3.8V	280V
0x00BB	BAT_RCHG_VOLT	24V	18.4V~CURVE_FV	±0.24V	18.4V
		48V	36.8V~CURVE_FV	±0.48V	36.8V
		96V	73.6V~CURVE_FV	±0.96V	73.6V
		380V	270V~CURVE_FV	±3.8V	270V
0x00BC	BAT_OV_ALM_VOLT	24V	30V~33V	±0.24V	31V
		48V	60V~66V	±0.48V	62V
		96V	100V~114V	±0.96V	114V
		380V	400V~430V	±3.8V	420V
CAN:0x00C2 MOD:0x00C4	SYSTEM_CONFIG	ALL	N/A	N/A	0002h
0x0100	INV_OPERATION	ALL	N/A	N/A	0000h
0x0140	DIR_CTRL Note ii	ALL	00h(Charge)/ 01h(Discharge)	N/A	00h(Charge)

CAN bus/ Modbus Command		Model	Display value range	Tolerance	Default
0x0141	VOUT_SET_REV	24V	19~33V	±0.24V	19V
		48V	38~66V	±0.48V	38V
		96V	76~112V	±0.96V	76V
		380V	280~430V	±3.8V	280V
0x0142	IOUT_SET_REV	24V	-232 ~ -4.16A	±2.1A	-232A
		48V	-118 ~ -2.08A	±1.1A	-114A
		96V	-57 ~ -1.04A	±0.6A	-57A
		380V	-16~-0.3A	±0.15A	-16A
0x0143	BIDIR_CONFIG	ALL	00h(CV)/01h(Battery)	N/A	00h(CV)
0x0150	POUT_USER_CMD	ALL	-5000W~5000W	±2%Sn	0W
0x02D1	GRID_TIE_REMOTE	ALL	00h(dis)/01h(Connected)	N/A	01h(Connected)
0x02D2	CONNECT_UPPER_VOLT	ALL	100~120%	±1%F.S	110%Un
0x02D3	CONNECT_LOWER_VOLT	ALL	50~100%	±1%F.S	85%Un
0x02D4	CONNECT_UPPER_FREQ	ALL	50~55/ 60~65Hz	±0.05Hz	50.1Hz
			45~50/ 55~60Hz		
0x02D5	CONNECT_LOWER_FREQ	ALL	45~50/ 55~60Hz	±0.05Hz	47.5Hz
0x02D6	CONNECT_DLY_TIME	ALL	10~600sec	N/A	60sec
0x02D7	CONNECT_P_RATE	ALL	6~3000% or > 3000%(no limit)	N/A	65535(no limit)
0x02D8	RECONNECT_P_RATE	ALL	6~3000%	N/A	10% Pn /min
0x02E4	SAFTY_FUNC_CONFIG	ALL	N/A	N/A	0x0273h
0x02E5	COUNTRY_SET	ALL	N/A	N/A	00h: EN50549
0x02E8	CTRL_MODE	ALL	N/A	N/A	0040h(Fixed Pset/ Fixed PFset)
0x02E9	P_SET_RATE	ALL	6~3000%Pn/min	N/A	30%Pn/min
0x02EA	P_TAU	ALL	3~60	N/A	3(Time constant)
0x02EB	Q_TAU	ALL	3~60	N/A	3(Time constant)

CAN bus/ Modbus Command		Model	Display value range	Tolerance	Default
0x02EC	P_SET	ALL	0~100%	±2%Sn	100%Pn
0x02ED	Q_SET	ALL	-100~100%	±2%Sn	0%Qn
0x02EE	PF_SET	ALL	0.9~1 (over)/ 0.9~1(under)	±2%Sn	1 (PF)
0x02EF	PF_P_LOCKIN_V	ALL	0~120%	N/A	0%Un
0x02F0	PF_P_LOCKOUT_V	ALL	0~120%	N/A	0%Un
0x02F1	PF_P_CURVE_PF1	ALL	0.9~1 (over)/ 0.9~1(under)	±2%Sn	1 (PF)
0x02F2	PF_P_CURVE_P1	ALL	0~100%	±2%Sn	20%Pn
0x02F3	PF_P_CURVE_PF2	ALL	0.9~1 (over)/ 0.9~1(under)	±2%Sn	1 (PF)
0x02F4	PF_P_CURVE_P2	ALL	0~100%	±2%Sn	40%Pn
0x02F5	PF_P_CURVE_PF3	ALL	0.9~1 (over)/ 0.9~1(under)	±2%Sn	1 (PF)
0x02F6	PF_P_CURVE_P3	ALL	0~100%	±2%Sn	50%Pn
0x02F7	PF_P_CURVE_PF4	ALL	0.9~1 (over)/ 0.9~1(under)	±2%Sn	0.9(under) (PF)
0x02F8	PF_P_CURVE_P4	ALL	0~100%	±2%Sn	100%Pn
0x0327	Q_P_CURVE_Q1	ALL	-100(under)~100(over)%	±2%Sn	100%Qn
0x0328	Q_P_CURVE_P1	ALL	0~100%	±2%Sn	15%Pn
0x0329	Q_P_CURVE_Q2	ALL	-100(under)~100(over)%	±2%Sn	0%Qn
0x032A	Q_P_CURVE_P2	ALL	0~100%	±2%Sn	20%Pn
0x032B	Q_P_CURVE_Q3	ALL	-100(under)~100(over)%	±2%Sn	0%Qn
0x032C	Q_P_CURVE_P3	ALL	0~100%	±2%Sn	80%Pn
0x032D	Q_P_CURVE_Q4	ALL	-100(under)~100(over)%	±2%Sn	-100%Qn
0x032E	Q_P_CURVE_P4	ALL	0~100%	±2%Sn	90%Pn
0x035D	Q_V_MIN_COS	ALL	0~1	---	0(PF) (disable)
0x035E	Q_V_LOCKIN_P	ALL	0~20%	±2%Sn	0% (disable)
0x035F	Q_V_LOCKOUT_P	ALL	0~20%	±2%Sn	0% (disable)
0x0360	Q_V_CURVE_Q1	ALL	-100~100%	±2%Sn	100%Qn

CAN bus/ Modbus Command		Model	Display value range	Tolerance	Default
0x0361	Q_V_CURVE_V1	ALL	85~120%	±1%Un	93%Un
0x0362	Q_V_CURVE_Q2	ALL	-100~100%	±2%Sn	0%Qn
0x0363	Q_V_CURVE_V2	ALL	85~120%	±1%Un	94%Un
0x0364	Q_V_CURVE_Q3	ALL	-100~100%	±2%Sn	0%Qn
0x0365	Q_V_CURVE_V3	ALL	85~120%	±1%Un	106%Un
0x0366	Q_V_CURVE_Q4	ALL	-100~100%	±2%Sn	-100%Qn
0x0367	Q_V_CURVE_V4	ALL	85~120%	±1%Un	108%Un
0x3A0	P_V_CURVE_P1	ALL	0~100%	±2%Sn	100%Pn
0x3A1	P_V_CURVE_V1	ALL	85~120%	±1%Un	110%Un
0x3A2	P_V_CURVE_P2	ALL	0~100%	±2%Sn	100%Pn
0x3A3	P_V_CURVE_V2	ALL	85~120%	±1%Un	110%Un
0x3A4	P_V_CURVE_P3	ALL	0~100%	±2%Sn	0%Pn
0x3A5	P_V_CURVE_V3	ALL	85~120%	±1%Un	115%Un
0x3A6	P_V_CURVE_P4	ALL	0~100%	±2%Sn	0%Pn
0x3A7	P_V_CURVE_V4	ALL	85~120%	±1%Un	115%Un
0x03D9	UVRT_VOLT1	ALL	0~100%	±1%Un	5%
0x03DA	UVRT_TIME1	ALL	0~100sec	---	0sec
0x03DB	UVRT_VOLT2	ALL	0~100%	±1%Un	5%
0x03DC	UVRT_TIME2	ALL	0~100sec	---	0.25sec
0x03DD	UVRT_VOLT3	ALL	0~100%	±1%Un	85%
0x03DE	UVRT_TIME3	ALL	0~100sec	---	3sec
0x03DF	UVRT_VOLT4	ALL	0~100%	±1%Un	85%
0x03E0	UVRT_TIME4	ALL	0~100sec	---	3sec
0x03E1	UVRT_VOLT5	ALL	0~100%	±1%Un	85%
0x03E2	UVRT_TIME5	ALL	0~100sec	---	3sec
0x03E3	UVRT_VOLT6	ALL	0~100%	±1%Un	85%
0x03E4	UVRT_TIME6	ALL	0~100sec	---	3sec
0x03E5	UVRT_VOLT7	ALL	0~100%	±1%Un	85%
0x03E6	UVRT_TIME7	ALL	0~100sec	---	3sec
0x0468	OVRT_VOLT1	ALL	100~130%	±1%Un	125%

CAN bus/ Modbus Command		Model	Display value range	Tolerance	Default
0x0469	OVRT_TIME1	ALL	0~100sec	---	0sec
0x046A	OVRT_VOLT2	ALL	100~130%	±1%Un	125%
0x046B	OVRT_TIME2	ALL	0~100sec	---	0.1sec
0x046C	OVRT_VOLT3	ALL	100~130%	±1%Un	120%
0x046D	OVRT_TIME3	ALL	0~100sec	---	0.1sec
0x046E	OVRT_VOLT4	ALL	100~130%	±1%Un	120%
0x046F	OVRT_TIME4	ALL	0~100sec	---	5sec
0x0470	OVRT_VOLT5	ALL	100~130%	±1%Un	115%
0x0471	OVRT_TIME5	ALL	0~100sec	---	5sec
0x0472	OVRT_VOLT6	ALL	100~130%	±1%Un	115%
0x0473	OVRT_TIME6	ALL	0~100sec	---	60sec
0x0474	OVRT_VOLT7	ALL	100~130%	±1%Un	110%
0x0475	OVRT_TIME7	ALL	0~100sec	---	60sec
0x0609	LFSMO_FREQ_START	ALL	50.2~55/ 60.2~65Hz	±0.05Hz	50.2Hz
0x060A	LFSMO_FREQ_STOP	ALL	50~LFSMO_FREQ_START/ 60~LFSMO_FREQ_STARTHz/ 0 (disable)	±0.05Hz	0 (disable)
0x060B	LFSMO_STOP_DLY	ALL	0~600sec	---	0sec
0x060C	LFSMO_DROOP_RATE	ALL	0.5~12%	---	5%
0x060D	LFSMO_ACTIVE_DLY	ALL	0~2sec	---	0sec
0x060E	LFSMU_FREQ_START	ALL	45~49.8/ 55~59.8Hz	±0.05Hz	49.8Hz
0x060F	LFSMU_FREQ_STOP	ALL	LFSMU_FREQ_START~50/ LFSMU_FREQ_START~60Hz/ 0 (disable)	±0.05Hz	0 (disable)
0x0610	LFSMU_STOP_DLY	ALL	0~600sec	---	30sec
0x0611	LFSMU_DROOP_RATE	ALL	0.5~12%	---	2%
0x0612	LFSMU_ACTIVE_DLY	ALL	0~2sec	---	0sec

CAN bus/ Modbus Command		Model	Display value range	Tolerance	Default
0x0613	LFSM_P_REF	ALL	0: PREF = Pn 1: PREF = PM	---	0
0x0640	UVP1_VOLT	ALL	10~100%	±1%Un	80%Un
0x0641	UVP1_TIME	ALL	0.1~300sec	---	3sec
0x0642	UVP2_VOLT	ALL	10~100%	±1%Un	45%Un
0x0643	UVP2_TIME	ALL	0.1~5sec	---	0.3sec
0x0644	UVP3_VOLT	ALL	10~100%	±1%Un	45%Un
0x0645	UVP3_TIME	ALL	0.1~5sec	---	0.3sec
0x0646	OVP1_VOLT	ALL	100~130%	±1%Un	125% Un
0x0647	OVP1_TIME	ALL	0.1~300sec	---	0.1sec
0x0648	OVP2_VOLT	ALL	100~130%	±1%Un	125%Un
0x0649	OVP2_TIME	ALL	0.1~5sec	---	0.1sec
0x064A	OVP3_VOLT	ALL	100~130%	±1%Un	125%Un
0x064B	OVP3_TIME	ALL	0.1~5sec	---	0.1sec
0x064C	UFP1_FREQ	ALL	45~50/ 55~60Hz	±0.05Hz	47.5Hz
0x064D	UFP1_TIME	ALL	0.1~300sec	---	0.1sec
0x064E	UFP2_FREQ	ALL	45~50/ 55~60Hz	±0.05Hz	47.5Hz
0x064F	UFP2_TIME	ALL	0.1~5sec	---	0.1sec
0x0650	UFP3_FREQ	ALL	45~50/ 55~60Hz	±0.05Hz	47.5Hz
0x0651	UFP3_TIME	ALL	0.1~5sec	---	0.1sec
0x0652	OFP1_FREQ	ALL	50~55/ 60~65Hz	±0.05Hz	51.5Hz
0x0653	OFP1_TIME	ALL	0.1~300sec	---	0.1sec
0x0654	OFP2_FREQ	ALL	50~55/ 60~65Hz	±0.05Hz	51.5Hz
0x0655	OFP2_TIME	ALL	0.1~5sec	---	0.1sec

CAN bus/ Modbus Command		Model	Display value range	Tolerance	Default
0x0656	OFP3_FREQ	ALL	50~55/ 60~65Hz	±0.05Hz	51.5Hz
0x0657	OFP3_TIME	ALL	0.1~5sec	---	0.1sec
0x0658	OVP10MIN_VOLT	ALL	100~115%	±1%Un	110%Un
0x0659	ROCOF_SLOPE	ALL	1~10Hz/sec	---	2.5Hz/sec
0x065A	ROCOF_WINDOW_TIME	ALL	0.1~1sec	±1%Un	0.5sec

NOTE :

i.READ_CHG_CURR will display ZERO amp when output current is less than values in the table below.

Model	Minimum readable
24V	2.1A±2.1A
48V	1.1A±1.1A
96V	0.6A±0.6A
380V	0.15A±0.15A

ii.BIDIRECTIONAL CONFIG = 00h → for Bi-directional Auto-detection Mode.

※ DC voltage can be configured only through VOUT_SET. SVR is not supported.

※ Default IOUT_SET and IOUT_SET_REV are at their maximum values.

※ C/D control I/O is disabled

※ DIRECTION_CTRL is NOT available in this mode.

BIDIRECTIONAL CONFIG = 01h → for Bi-directional Battery

※ VOUT_SET/IOUT_SET/REVERSE_VOUT_SET/REVERSE_IOUT_SET can be used to set charge voltage/current and discharge voltage/current

※ C/D control is enabled, allowing direction control via external I/O.

※ DIRECTION_CTRL is available and can be used to set the operating direction (A/D or D/A).

iii.Owing to the limited write cycles of the EEPROM, it is advisable to consider using the SYSTEM_CONFIG (CAN:0x00C2 ; MOD:0x00C4) command to select an appropriate EEPROM writing logic, especially if communication settings are frequently altered.

iv.The tolerance of CURVE_CC_TIMEOUT, CURVE_CV_TIMEOUT, and CURVE_FV_TIMEOUT increase over time. The maximum timing tolerance is ±5 minutes.

7. Protections and Trouble Shooting

7.1 Protections

7.1.1 Over Temperature Protection (OTP) and Alarm

Built-in thermal detection circuit, once the internal temperature exceeds the threshold value, the supply will shut down automatically (the fans will still be running to cool down the supply). Please switch off the device, remove all possible causes and then leave the supply cooling down to a normal working temperature (approximate 10 minutes - 1 hour) before repower on again. Maximum output current 4mA.

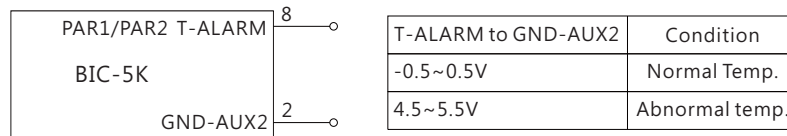

7.1.2 AC Fail Protection

When AC voltage/frequency is abnormal, BIC-5K will enter protection mode to prevent damaging itself or affect quality of the grid no matter which conversion it is, D/A or A/D. The supply will restore automatically when AC voltage/frequency back to normal.

7.2 Trouble Shooting

In the event of a fault, the indicator lights on. The device will display fault signals to assist in troubleshooting. Faults can be identified by the number of flashes of the red LED. It is recommended to follow the table below for inspection and troubleshooting. If the issue cannot be resolved, please contact a nearby Mean Well authorized distributor or the manufacturer for assistance.

Fault signal	Possible cause	Suggestions for Fault correction
 Red : Blink	High Ambient temperature alarm	This alarm is for notification purposes only and does not shut down the device. However, it is still recommended to reduce the operating temperature or loads.
 Red LED flashes one time	Over load protection	Check if the load requires high startup current, such as inductive or capacitance loads. After the fault condition is removed, repower the inverter for operation.
	Short circuit protection	Check if the loads exceed the rated value or if the circuit is shorted.
 Red LED flashes twice	Overvoltage protection	Check if the battery or DC bidirectional converter voltage is too high. After resolving the issue, restart the device to recover normal operation.
 Red LED flashes three times	Over/under Temperature Protection (OTP/UTP)	OTP : Check if the cooling vents are unobstructed. If the ambient temperature is too high, reduce the load or lower the environmental temperature. UTP: Check if the ambient temperature is too low, after the fault is cleared, the device can restart automatically.
 Red LED flashes four times	Fan Fault Protection (Fan-lock)	Check if the fan is blocked by dust or debris. After clearing the fault, power cycle the device to resume normal operation.
 Red LED flashes five times	Other Conditions	When AC power is off but DC energy is still present, the device maintains operational to record status data. The LED will flash red five times and remain in AC Fail state. When AC power is restored or reconnected, the BIC-5K will resume normal operation. Additionally, if the actual AC voltage or frequency differs from the configured values, this protection may be triggered. In this case, adjust the settings to the correct values, and the BIC-5K will return to normal operation.

8. Warranty

This product provides five years warranty under normal usage. Do not replace parts or any form of modification to the product in order to keep the warranty effectively.

※ MEAN WELL possesses the right to adjust the content of this manual.
Please refer to the latest version of our manual on our website.
<https://www.meanwell.com>



9. Environmental declaration information

https://www.meanwell.com/Upload/PDF/RoHS_PFOS.pdf
https://www.meanwell.com/Upload/PDF/REACH_SVHC.pdf
https://www.meanwell.com/Upload/PDF/Declaration_RoHS-E.pdf

明緯企業股份有限公司

MEAN WELL ENTERPRISES CO., LTD.

248 新北市五股區五權三路 28 號

No.28, Wuquan 3rd Rd., Wugu Dist., New Taipei City 248, Taiwan

Tel: 886-2-2299-6100 Fax: 886-2-2299-6200

<http://www.meanwell.com> E-mail: info@meanwell.com